

Optimo 19L

FR

NL

DE

EN

ES

PT

RU

KK

UK



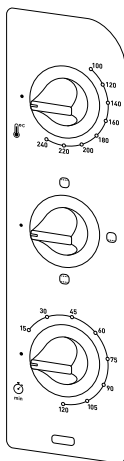
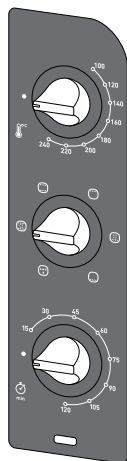
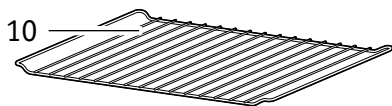
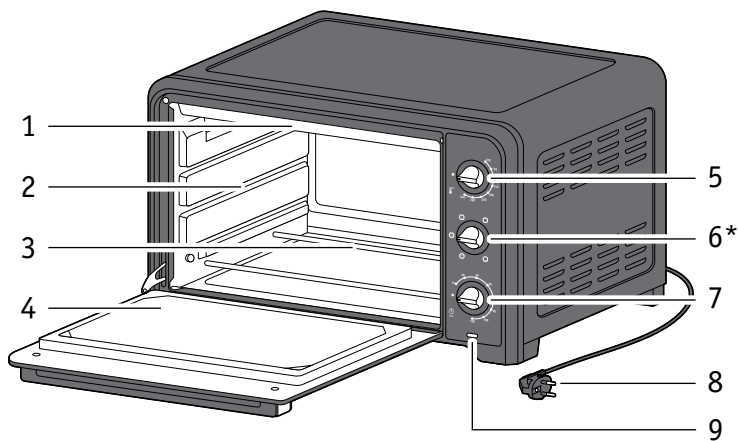

* selon modèle - afhankelijk van het model - je nach Modell - depending on the model - según el modelo - consoante o modelo -
 В зависимости от модели - үлгіге байланысты - залежно від моделі

DESCRIPTION

- 1 Résistance supérieure
- 2 Parois en acier à revêtement aluminium
- 3 Résistance inférieure
- 4 Porte double parois
- 5 Bouton de réglage température
- 6 Bouton des fonctions
- 7 Bouton de minuterie
- 8 Cordon d'alimentation
- 9 Voyant de fonctionnement
- 10 Grille réversible
- 11 Plat lèche-frite*

BESCHRIJVING

- 1 Bovenste verwarmingselement
- 2 Stalen wanden met aluminiumcoating
- 3 Onderste verwarmingselement
- 4 Dubbelwandige deur
- 5 Regelbare thermostaatknop
- 6 Functieknop
- 7 Timerknop
- 8 Snoer
- 9 Aan/uit-controlelampje
- 10 Omkeerbaar grillrooster
- 11 Ovenschaal*

BESCHREIBUNG

- 1 Oberes Heizelement
- 2 Aluminiumbeschichtete Stahlwände
- 3 Unteres Heizelement
- 4 Doppelwandige Tür
- 5 Temperaturregler
- 6 Funktionsknopf
- 7 Timer-Knopf
- 8 Netzkabel
- 9 Betriebskontrollleuchte
- 10 Umkehrbarer Grillrost
- 11 Backblech*

DESCRIPTION

- 1 Top heating element
- 2 Aluminium coated steel walls
- 3 Bottom heating element
- 4 Double-wall door
- 5 Temperature control button
- 6 Functions button
- 7 Timer button
- 8 Power cord
- 9 Power indicator light
- 10 Reversible grill rack
- 11 Food tray*

DESCRIPCIÓN

- 1 Resistencia superior
- 2 Paredes de acero inoxidable con recubrimiento de aluminio
- 3 Resistencia inferior
- 4 Puerta de doble cristal
- 5 Botón de ajuste de temperatura
- 6 Botón de funciones
- 7 Botón de temporizador
- 8 Cable de alimentación
- 9 Indicador de funcionamiento
- 10 Parrilla de grill reversible
- 11 Bandeja de comida*

* selon modèle - afhankelijk van het model - je nach Modell - depending on the model - según el modelo - consoante o modelo -
В зависимости от модели - үлгіге байланысты - залежно від моделі

DESCRIÇÃO

- 1 Resistência superior
- 2 Paredes de aço revestidas a alumínio
- 3 Resistência inferior
- 4 Porta de parede dupla
- 5 Botão de regulação da temperatura
- 6 Botão das funções
- 7 Botão temporizador
- 8 Cabo de alimentação
- 9 Luz piloto de funcionamento
- 10 Grelha reversível
- 11 Tabuleiro*

ОПИСАНИЕ

- 1 Верхний нагревательный элемент
- 2 Стальные стенки с алюминиевым покрытием
- 3 Нижний нагревательный элемент
- 4 Двухслойная дверца
- 5 Кнопка контроля температуры
- 6 Кнопка выбора функций
- 7 Кнопка таймера
- 8 Кабель питания
- 9 Индикатор питания
- 10 Двухсторонняя решетка для гриля
- 11 Противень*

СИПАТТАМА

- 1 Жоғарғы қыздыру элементі
- 2 Алюминиймен қапталған болат қабырғалар
- 3 Төменгі қыздыру элементі
- 4 Қос қабырғалы есік
- 5 Температураны басқару түймесі
- 6 Функциялар түймесі
- 7 Таймер түймесі
- 8 Қуат сымы
- 9 Қуат индикаторының шамы
- 10 Аударуға болатын гриль сәресі
- 11 Тамақ науасы*

ОПИС

- 1 Верхній нагрівальний елемент
- 2 Сталеві стінки з алюмінієвим покриттям
- 3 Нижній нагрівальний елемент
- 4 Дверцята з подвійними стінками
- 5 Кнопка регулювання температури
- 6 Кнопка вибору функцій
- 7 Кнопка таймера
- 8 Шнур живлення
- 9 Світловий індикатор живлення
- 10 Двостороння решітка для гриля
- 11 Піднос*

* selon modèle - afhankelijk van het model - je nach Modell - depending on the model - según el modelo - consoante o modelo -
В зависимости от модели - үлгіге байланысты - залежно від моделі

1

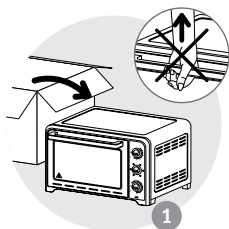

1

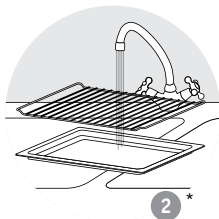

2*

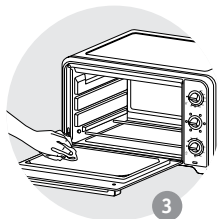

3

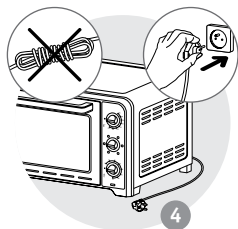

4

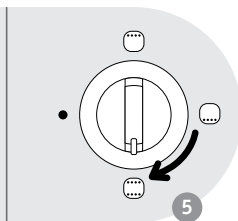
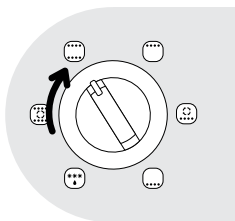

5

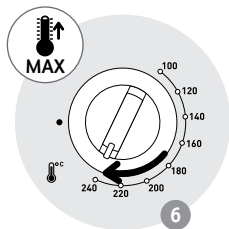

6

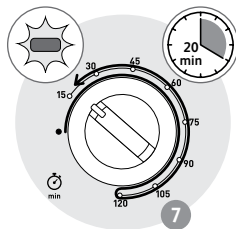

7

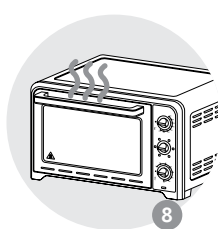

8

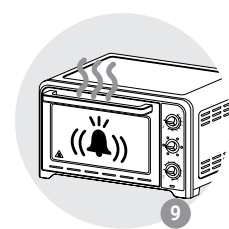

9

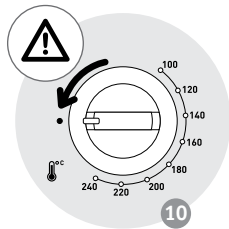

10

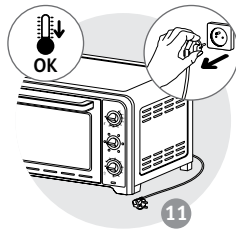

11

* selon modèle - afhankelijk van het model - je nach Modell - depending on the model - según el modelo - consoante o modelo -
В зависимости от модели - үлгіге байланысты - залежно від моделі

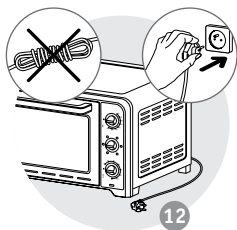

12

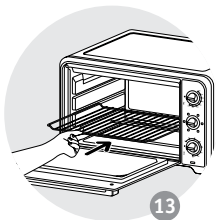

13

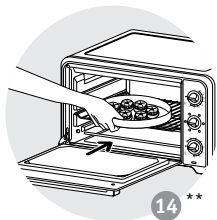

14 **

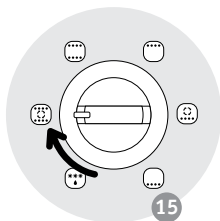

15

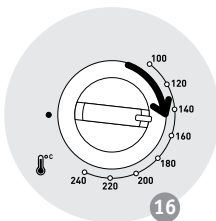

16

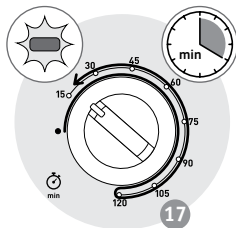

17

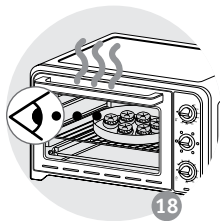

18

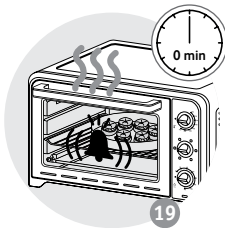

19

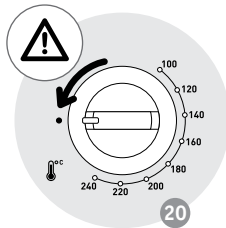

20

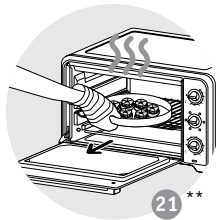

21 **

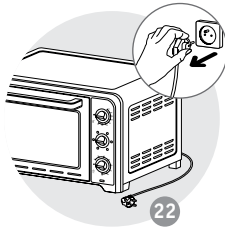

22

* selon modèle
afhankelijk van het model
je nach Modell
depending on the model
según el modelo
consoante o modelo
В зависимости от модели
үлгіге байланысты
залежно від моделі

** Plat non fourni avec l'appareil - Schaal niet bij het apparaat inbegrepen - Platte nicht im Lieferumfang inbegriffen - The dish is not supplied with the appliance - El plato no es suministrado con el aparato - Travessa não fornecida com o aparelho - Блюдо не входит в комплект - Құрылғымен бірге тәрелке қамтамасыз етілмейді - Блюдо не входит в комплект поставки приладу

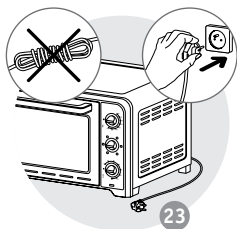

23

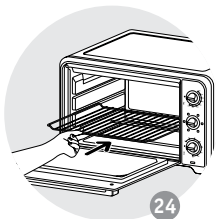

24

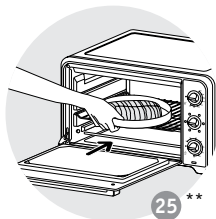

25 **

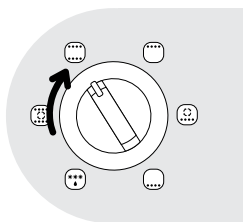

26

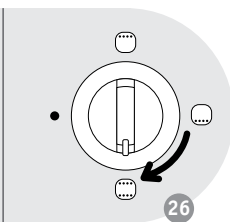

27

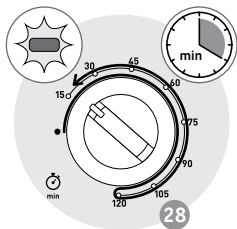
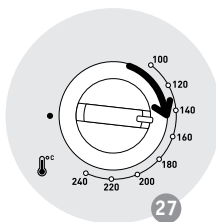

29

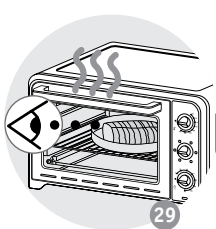

30

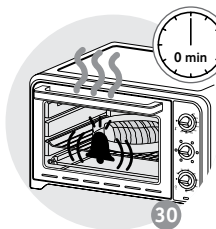

31

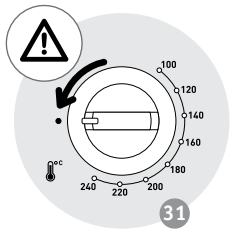

32

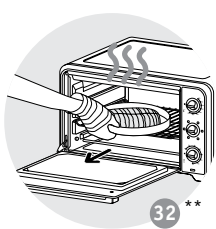

33

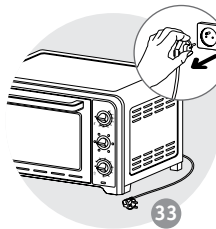

34

** Plat non furni avec l'appareil - Schaal niet bij het apparaat inbegrepen - Platte nicht im Lieferumfang inbegriffen - The dish is not supplied with the appliance - El plato no es suministrado con el aparato - Travessa não fornecida com o aparelho - Блюдо не входит в комплект - Құрылғымен бірге тәрелке қамтамасыз етілмейді - Блюдо не входит в комплект поставки прибора

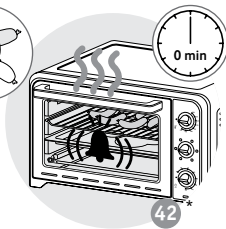
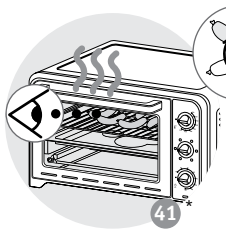
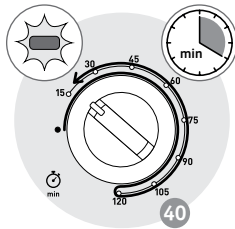
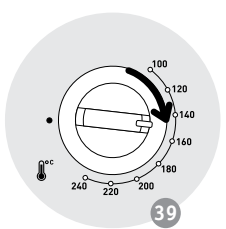
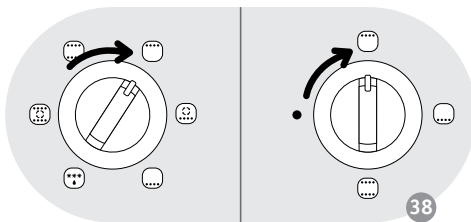
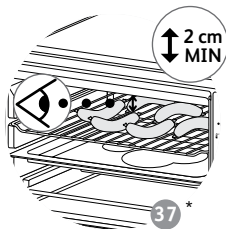
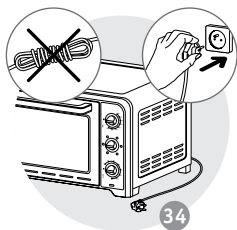

* selon modèle - afhankelijk van het model - je nach Modell - depending on the model - según el modelo - consoante o modelo -
В зависимости от модели - үлгіге байланысты - залежно від модели

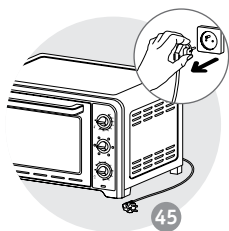
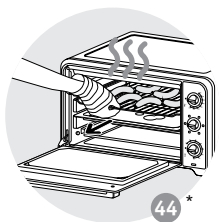
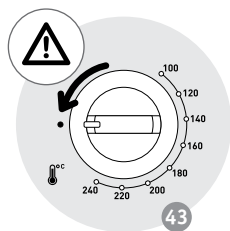

* selon modèle - afhankelijk van het model - je nach Modell - depending on the model - según el modelo - consoante o modelo -
В зависимости от модели - үлгіге байланысты - залежно від моделі

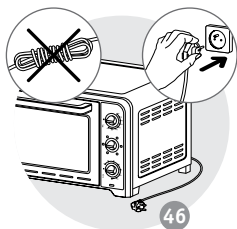

46

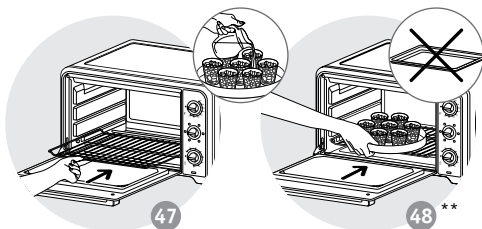

47

48 **

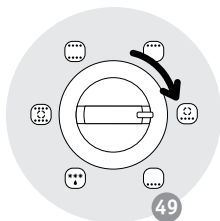

49

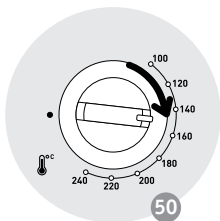

50

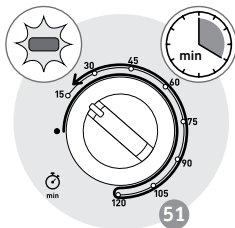

51

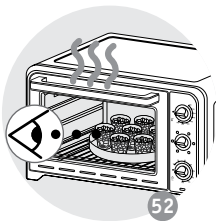

52

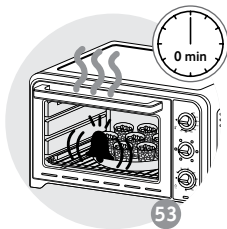

53

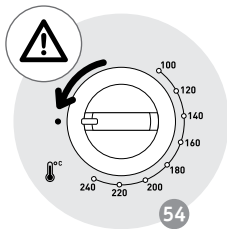

54

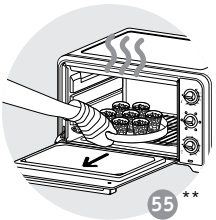

55 **

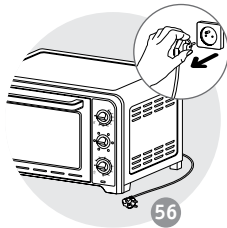

56

* selon modèle
afhankelijk van het model
je nach Modell
depending on the model
según el modelo
consoante o modelo
В зависимости от модели
үлгіге байланысты
залежно від моделі

** Plat non fourni avec l'appareil - Schaal niet bij het apparaat inbegrepen - Platte nicht im Lieferumfang inbegriffen - The dish is not supplied with the appliance - El plato no es suministrado con el aparato - Travessa não fornecida com o aparelho - Блюдо не входит в комплект - Құрылғымен бірге тәрелке қамтамасыз етілмейді - Блюдо не входит в комплект поставки приладу

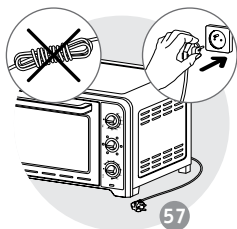

57

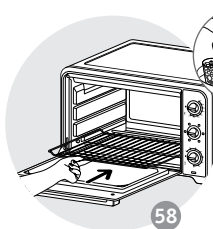

58

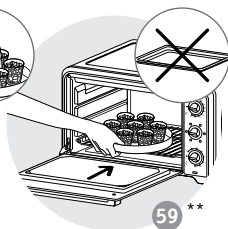

59 **

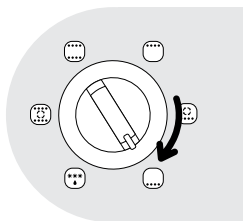

60

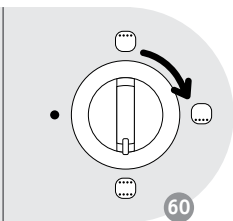

61

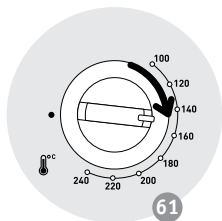

62

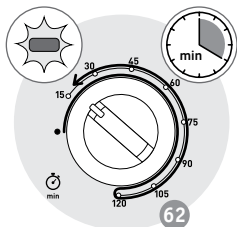

63

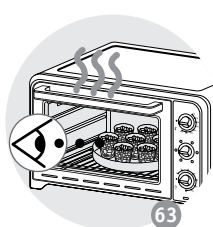

64

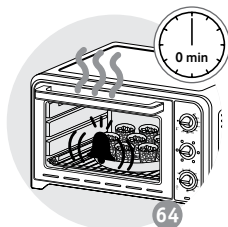

65

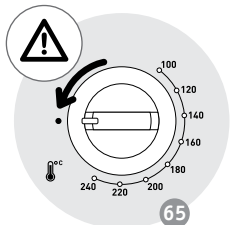

66 **

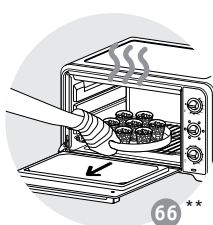

67

** Plat non furni avec l'appareil - Schaal niet bij het apparaat inbegrepen - Platte nicht im Lieferumfang inbegriffen - The dish is not supplied with the appliance - El plato no es suministrado con el aparato - Travessa não fornecida com o aparelho - Блюдо не входит в комплект - Құрылғымен бірге тәрелке қамтамасыз етілмейді - Блюдо не входит в комплект поставки прибора

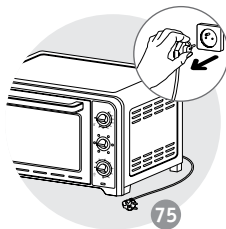
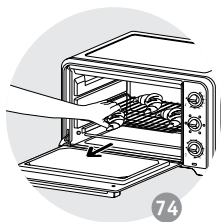
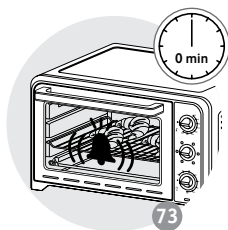
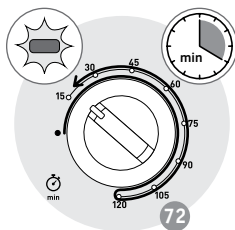
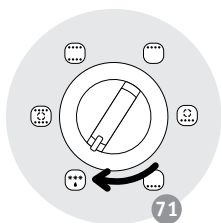
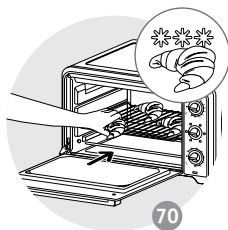
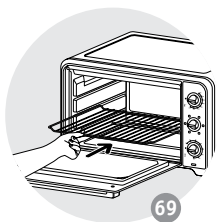
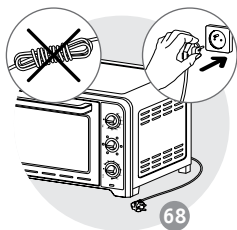

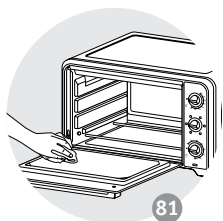
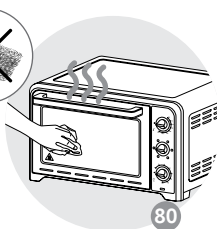
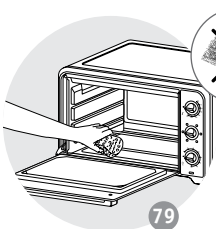
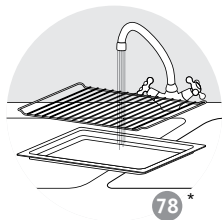
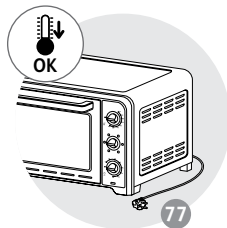
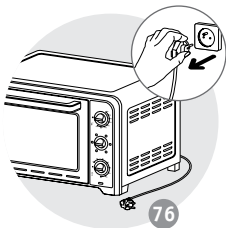

* selon modèle - afhankelijk van het model - je nach Modell - depending on the model - según el modelo - consoante o modelo -
В зависимости от модели - үлгіге байланысты - залежно від моделі



| | x4 | | | 10mins | 240 | 20 |
|--|-------|--|--|--------|-----|--------|
| | 870g | | | 10mins | 230 | 65 |
| | 750g | | | 10mins | 240 | 42 |
| | 500g | | | - | 240 | 50 |
| | 1000g | | | - | 240 | 80 |
| | x4 | | | - | 240 | 22 |
| | x8 | | | - | 240 | 15 |
| | 350g | | | 10mins | 210 | 12 |
| | 350g | | | 10mins | 210 | 11 |
| | | | | 10mins | 240 | 40 |
| | 350g | | | 10mins | 240 | 16 |
| | | | | - | 240 | 31 |
| | | | | 10mins | 200 | 40 |

* selon modèle - afhankelijk van het model - je nach Modell - depending on the model - según el modelo - consoante o modelo -
В зависимости от модели - үлгіге байланысты - залежно від моделі

| | | | | | | min |
|--|----|--|--|--------|-----|-----|
| | | | | 10mins | 200 | 18 |
| | | | | 10mins | 200 | 40 |
| | x6 | | | 10mins | 200 | 10 |
| | x6 | | | 10mins | 200 | 16 |
| | | | | 10mins | 240 | 55 |
| | | | | 10mins | 240 | 25 |

* selon modèle - afhankelijk van het model - je nach Modell - depending on the model - según el modelo - consoante o modelo -
 В зависимости от модели - үлгіге байланысты - залежно від моделі

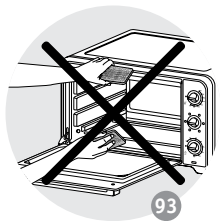
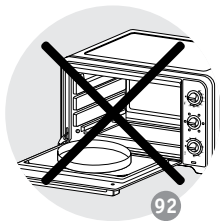
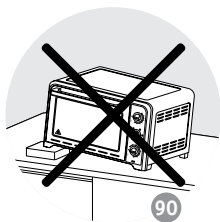
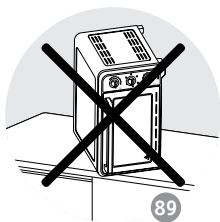
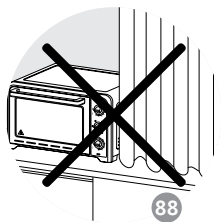
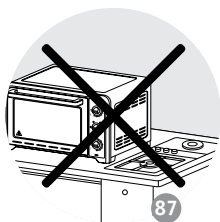
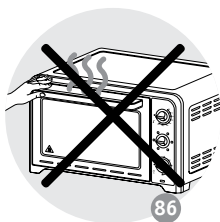
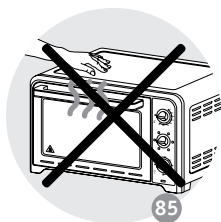
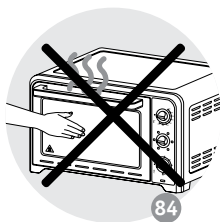
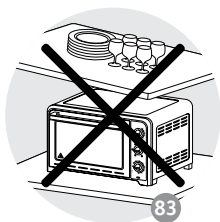
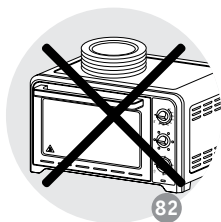

GUARANTEE COUNTRY LIST

|  |  |  |  |
|---|---|---|--|
| ARGENTINA | 0800-122-2732 | 2 años 2 years | GRUPE SEB ARGENTINA S.A. Billinghurst 1833 3° C1425DTK Capital Federal Buenos Aires |
| ՀԱՅԱՍՏԱՆ ARMENIA | 010 55-76-07 | 2 տարի 2 years | ՓԲԸ «ԳՐՈՒՊԱ ՍԵԲ» 125171, Մոսկվա, Լենինգրադսկոյե շոսսե, Դ. 16Ա, շրջ. 3 |
| AUSTRALIA | 1300307824 | 1 year | GRUPE SEB AUSTRALIA PO Box 7535, Silverwater NSW 2128 |
| ÖSTERREICH AUSTRIA | 01 890 3476 | 2 Jahre 2 years | SEB ÖSTERREICH GmbH Campus 21 - Businesspark Wien Süd, Liebermannstr. A02 702 2345 Brunn am Gebirge |
| البحرين BAHRAIN | 17716666 | 1 year | www.tefal-me.com |
| БЕЛАРУСЬ BELARUS | 017 2239290 | 2 года 2 years | ЗАО «Группа СЕБ-Восток», 125171, Москва, Ленинградское шоссе, д. 16А, стр. 3 |
| BELGIQUE BELGIE BELGIUM | 070 23 31 59 | 2 ans 2 jaar 2 years | GRUPE SEB BELGIUM SA NV 25 avenue de l'Espérance - ZI 6220 Fleurus |
| BOSNA I HERCEGOVINA | Info-linija za potrošače 033 551 220 | 2 godine 2 years | SEB Development Predstavništvo u BiH Vrazova 8/II 71000 Sarajevo |
| BRASIL BRAZIL | 11 2915-4400 | 1 ano 1 year | SEB COMERCIAL DE PRODUTOS DOMÉSTICOS LTDA Rua Venâncio Aires, 433, Pompéia, São Paulo/SP |
| БЪЛГАРИЯ BULGARIA | 0700 10 330 | 2 години 2 years | ГРУП СЕБ БЪЛГАРИЯ ЕООД бул. България 81 В, ет. 5 1404 София |
| CANADA | 1-800-418-3325 | 1 an 1 year | GRUPE SEB CANADA 345 Passmore Avenue Toronto, ON M1V 3N8 |
| CHILE | 12300 209207 | 2 años 2 years | GRUPE SEB CHILE Comercial Ltda Av. Providencia, 2331, piso 5, oficina 501 Santiago |
| COLOMBIA | 018000520022 | 2 años 2 years | GRUPE SEB COLOMBIA Apartado Aereo 172, Kilometro 1 Via Zipaquirá Cajica Cundinamarca |
| HRVATSKA CROATIA | 01 30 15 294 | 2 godine 2 years | SEB mku & p.d.o.o. Vodnjanska 26, 10000 Zagreb |
| ČESKÁ REPUBLIKA CZECH REPUBLIC | 731 010 111 | 2 roky 2 years | Groupe SEB ČR s.r.o. Futurama Business Park (budova A) Sokolovská 651/136a 186 00 Praha 8 |
| DANMARK DENMARK | 44 663 155 | 2 år 2 years | GRUPE SEB NORDIC AS Tempovej 27 2750 Ballerup |
| مصر EGYPT | 16622 | سنة واحدة 1 year | جروب سب ايجيبت القاهرة: ١٢١ شارع الحجاز، مصر الجديدة الإسكندرية: طريق ٤ مايو، سموحة |

| | | | |
|--|------------------|---------------------|--|
| EESTI ESTONIA | 668 1286 | 2 aastat 2 years | GRUPE SEB POLSKA Sp. z o.o. ul. Bukowińska 22b 02-703 Warszawa |
| SUOMI FINLAND | 09 622 94 20 | 2 Vuotta 2 years | Grøupe SEB Finland Kutojantie 7 02630 Espoo |
| France Continentale + Guadeloupe, Martinique, Réunion, Saint-Martin | 09 74 50 47 74 | 1 an 1 year | GRUPE SEB France Service Consommateur Tefal 112 Ch. Moulin Carron, TSA 92002 69134 ECULLY Cedex |
| DEUTSCHLAND GERMANY | 0212 387 400 | 2 Jahre 2 years | GRUPE SEB DEUTSCHLAND GmbH / KRUPS GmbH Theodor-Stern-Kai 1 60486 Frankfurt am Main |
| ELLADA GREECE | 2106371251 | 2 χρόνια 2 years | SEB GROUPE ΕΛΛΑΔΟΣ Α.Ε. Οδός Καβαλιεράτου 7 Τ.Κ. 145 64 Κ. Κηφισιά |
| 香港 HONG KONG | 8130 8998 | 1 year | SEB ASIA Ltd. Room 903, 9/F, South Block, Skyway House 3 Sham Mong Road, Tai Kok Tsui, Kowloon Hong-Kong |
| MAGYARORSZÁG HUNGARY | 06 1 801 8434 | 2 év 2 years | GRUPE SEB CENTRAL-EUROPE Kft. Táviró köz 4 2040 Budaörs |
| INDONESIA | +62 21 5793 7007 | 1 year | GRUPE SEB INDONESIA (Representative office) Sudirman Plaza, Plaza Marein 8th Floor JL Jendral Sudirman Kav 76-78, Jakarta 12910, Indonesia |
| ITALIA ITALY | 1 99 207 354 | 2 anni 2 years | GRUPE SEB ITALIA S.p.A. Via Montefeltro, 4 20156 Milano |
| 日本 JAPAN | 0570-077772 | 1 year | 株式会社グループセブジャパン 〒144-0042 東京都大田区羽田旭町11-1 羽田クロノゲート事務棟5F |
| الأردن JORDAN | 5665505 | 1 year | www.tefal-me.com |
| ҚАЗАҚСТАН KAZAKHSTAN | 727 378 39 39 | 2 жыл 2 years | ЖАҚ «Группа СЕБ- Восток» 125171, Мәскеу, Ленинградское шоссесі, 16А, 3 үйі |
| 한국어 KOREA | 1588-1588 | 1 year | (유)그룹 세브 코리아 서울시 종로구 청계천로 35 관정빌딩 2층 110- 790 |
| الكويت KUWAIT | 24831000 | 1 year | www.tefal-me.com |
| LATVJA LATVIA | 6 616 3403 | 2 gadi 2 years | GRUPE SEB POLSKA Sp. z o.o. ul. Bukowińska 22b, 02-703 Warszawa |
| لبنان LEBANON | 4414727 | 1 year | www.tefal-me.com |
| LIETUVA LITHUANIA | 5 214 0057 | 2 metai 2 years | GRUPE SEB POLSKA Sp. z o.o. ul. Bukowińska 22b, 02-703 Warszawa |
| LUXEMBOURG | 0032 70 23 31 59 | 2 ans 2 years | GRUPE SEB BELGIUM SA NV 25 avenue de l'Espérance - ZI 6220 Fleurus |

| | | | |
|---|---|---------------------|---|
| МАКЕДОНИЈА MACEDONIA | (02) 20 50 319 | 2 години 2 years | Groupe SEB Bulgaria EOOD Office 1, floor 1, 52G Borovo St., 1680 Sofia - Bulgaria ГРУП СЕБ БЪЛГАРИЯ ДООЕЛ Ул. Борово 52 Г, сп. 1, офис 1, 1680 София, България |
| MALAYSIA | 603 7802 3000 | 1 year | GROUPE SEB MALAYSIA SDN. BHD Unit No. 402-403, Level 4, Uptown 2, No. 2, Jalan SS21/37, Damansara Uptown, 47400, Petaling Jaya, Selangor D.E Malaysia |
| MEXICO | (01800) 112 8325 | 1 año 1 year | Groupe.S.E.B. México, S.A. DE C.V. Goldsmith 38 Desp. 401, Col. Polanco Delegación Miguel Hidalgo 11 560 México D.F. |
| MOLDOVA | 22 929249 | 2 роки 2 years | ТОВ «Груп СЕБ Україна» 02121, Харківське шосе, 201-203, 3 поверх, Київ, Україна |
| NEDERLAND The Netherlands | 0318 58 24 24 | 2 jaar 2 years | GROUPE SEB NEDERLAND B.V. De Schutterij 27 3905 PK Veenendaal |
| NEW ZEALAND | 0800 700 711 | 1 year | GROUPE SEB NEW ZEALAND PO Box 17 – 298, Greenlane, 1546 Auckland New Zealand |
| NORGE NORWAY | 815 09 567 | 2 år 2 years | GROUPE SEB NORDIC AS Tempovej 27 2750 Ballerup |
| عمان سلطنة OMAN | 24703471 | 1 year | www.tefal-me.com |
| POLSKA POLAND | 801 300 420 koszt jak za połączenie lokalne | 2 lata 2 years | GROUPE SEB POLSKA Sp. z o.o. ul. Bukowińska 22b 02-703 Warszawa |
| PORTUGAL | 808 284 735 | 2 anos 2 years | GROUPE SEB IBÉRICA SA Urb. da Matinha Rua Projectada à Rua 3 Bloco1 - 3º B/D 1950 - 327 Lisboa |
| قطر QATAR | 44485555 | 1 year | www.tefal-me.com |
| REPUBLIC OF IRELAND | 01 677 4003 | 1 year | GROUPE SEB IRELAND Unit B3 Aerodrome Business Park, College Road, Rathcoole, Co. Dublin |
| ROMANIA | 0 21 316 87 84 | 2 ani 2 years | GROUPE SEB ROMÂNIA Str. Daniel Constantin nr. 8 010632 București |
| РОССИЯ RUSSIA | 495 213 32 30 | 2 года 2 years | ЗАО «Группа СЕБ-Восток», 125171, Москва, Ленинградское шоссе, д. 16А, стр. 3 |
| السعودية العربية المملكة SAUDI ARABIA | 920023701 | 1 year | www.tefal-me.com |
| SRBIJA SERBIA | 060 0 732 000 | 2 godine 2 years | SEB Développement Đorđa Stanojevića 11b 11070 Novi Beograd |

| | | | |
|---|---------------|-----------------------------|--|
| SINGAPORE | 6550 8900 | 1 year | GRUPE SEB SINGAPORE Pty Ltd. 59 Jalan Pemimpin, #04-01/02 L&Y Building Singapore 577218 |
| SLOVENSKO SLOVAKIA | 232 199 930 | 2 roky 2 years | GRUPE SEB Slovensko, spol. s r.o. Cesta na Senec 2/A 821 04 Bratislava |
| SLOVENIJA SLOVENIA | 02 234 94 90 | 2 leti 2 years | SEB d.o.o. Gregorčičeva ulica 6 2000 MARIBOR |
| SOUTH AFRICA | 0100202222 | 1 year | GS South Africa Building 17, PO BOX 107 The Woodlands Office Park, 20 Woodlands Drive, Woodmead 2080 |
| ESPAÑA SPAIN | 902 31 24 00 | 2 años 2 years | GRUPE SEB IBÉRICA S.A. C/ Almogàvers, 119-123, Complejo Ecourban 08018 Barcelona |
| SVERIGE SWEDEN | 08 594 213 30 | 2 år 2 years | TEFAL SVERIGE SUBSIDIARY OF GRUPE SEB NORDIC Truckvägen 14 A, 194 52 Upplands Väsby |
| SUISSE SCHWEIZ SWITZERLAND | 044 837 18 40 | 2 ans 2 Jahre 2 years | GRUPE SEB SCHWEIZ GmbH Thurgauerstrasse 105 8152 Glattbrugg |
| ประเทศไทย THAILAND | 02 769 7477 | 2 years | GRUPE SEB THAILAND 2034/66 Italthai Tower, 14th Floor, n° 14-02, New Phetchburi Road, Bangkapi, Huaykwang, Bangkok, 10320 |
| TÜRKIYE TURKEY | 444 40 50 | 2 YIL 2 years | GRUPE SEB ISTANBUL AS Dereboyu Cd. Bilim Sk. Sun Plaza No:5 K:2 Maslak/IST |
| المتحدة العربية الامارات UAE | 8002272 | 1 year | www.tefal-me.com |
| Україна UKRAINE | 044 300 13 04 | 2 роки 2 years | ТОВ «Груп СЕБ Україна» 02121, Харківське шосе, 201-203, 3 поверх, Київ, Україна |
| UNITED KINGDOM | 0345 602 1454 | 1 year | GRUPE SEB UK LTD Riverside House, Riverside Walk Windsor, Berkshire, SL4 1NA |
| U.S.A. | 800-395-8325 | 1 year | GRUPE SEB USA 2121 Eden Road Millville, NJ 08332 |
| VENEZUELA | 0800-7268724 | 2 años 2 years | GRUPE SEB VENEZUELA Av Eugenio Mendoza, Centro Letonia, Torre ING Bank, Piso 15, Ofc 155 Urb. La Castellana, Caracas |

25/03/2015

INTERNATIONAL GUARANTEE

Date of purchase: / Date d'achat / Fecha de compra / Data da compra / Data d'acquisto / Kaufdatum / Aankoopdatum / Kobsdato / Inköpsdatum / Kjøpsdato / Ostopäivä / Data zakupu / Data vânzării / [sigijimo data/ Ostakuupäev / Datum nakupa / Sorozatszám / Dátum nákupu / Pirkuma datums / Datum Kupovine / Datum kupnje / Data cumpărării / Datum nákupu / Tarikh pembelian / Tanggal pembelian / Ngày mua hàng / Satın alma tarihi / Дата продажи / Дата на закупване / Датум на купување / Сатылган мерзімі / Ημερομηνία αγοράς / Կաճառքի օրը / 購買日期 / 購入日 / 구입일자 / تاريخ الشراء / تاريخ خري

Product reference: / Référence du produit / Referencia del producto / Nome do produto / Tipo de produto / Typnummer des Gerätes / Artikelnummer van het apparaat / Referencenummer / Produktreferenz / Atrikkelnummer / Tuotenumero / referencia produktu / Model / Gaminio numeris / Toote viitenumber / Tip aparata / Vársírlás kelte / Тип výrobku / Produkta atsauce numurs / Model proizvoda / Oznaka proizvoda / Cod produs / Produk rujukan / Referensi produk / Mã sản phẩm / Ürün kodu / Модель / Модель / Модел на уреда / Моделі / Кодовός προϊόντος / Уηηήη / 產品編號 / 製品番号 / 제품명 / مرجع المنتج الكامل / مرجع المنتج الكامل

Retailer name & address: / Nom et adresse du vendeur / Nombre y dirección del minorista / Nome e endereço do revendedor / Nome e indirizzo del negozio / Name und Anschrift des Händlers / Naam en adres van de dealer / Forhandler navn & adresse / Aterförsäljarens namn och adress / Forhandler navn og adresse / Jälleenmyyjän nimi ja osoite / nazwa i adres sprzedawcy / Numele și adresa vânzătorului / Parduotuvės pavadinimas ir adresas / Müüja kauplus ja aadress / Naziv in naslov trgovine / Tipusszám / Názov a adresa predajcu / Veikala nosaukums un adrese / Naziv i adresa maloprodaje / Naziv i adresa prodavca / Naziv i adresa prodajnog mjesta / Nume și adresă vânzător / Název a adresa prodejce / Nama dan alamat penjual / Nama Toko Penjual dan alamat / Tên và địa chỉ cửa hàng bán/ Sateci firmann adi ve adresi / Название и адрес продавца / Назва и адреса продавця / Търговски обект / Назив и адреса на продавницата / Сатушынын аты және мекен-жайы / Εμπορική και διανομική καταστήματος / Կաճառքի անվանումը և հասցեն / 零售商的店名和地址 / 販売店名、住所 / 소매점 이름과 주소 / نام نرس خردہ فروش / عنوانه و خولانه / اسم بائع التجزئة و خولانه

Distributor stamp / Cachet distributeur / Sello del distribuidor / Carimbo do revendedor / Timbro del negozio / Händlerstempel / Stempel van de dealer / Forhandler stempel / Aterförsäljarens stämpel / Forhandler stempel / Jälleenmyyjän leima / pieczęć sprzedawcy / Štampila vânzătorului / Antspaudas / Tempel / Žig trgovine / Eladó neve, címe/ Razliko predajcu / Zīmogs / Pečat maloprodaje/ Pečat prodavca / Pečat prodajnog mjesta / Štampila vânzătorului/ Razliko prodajce/ Car peruncit / Car dari Toko Penjual / Cửa hàng bán dòng dấu/ Sateci Firmann Kaçesi / Печатка продавца / Печатка продажца / Печат на продавницата / Печат на продавницата / Сатушының мори / Σφραγίδα καταστήματος / Կաճառքի կիխրը / 零售商的蓋印 / 販売店印/販売店印/소매점 직인 / مهر خردہ فرو / ختم بائع التجزئة و خولانه

9100019913