

NAGACOLONNE XL

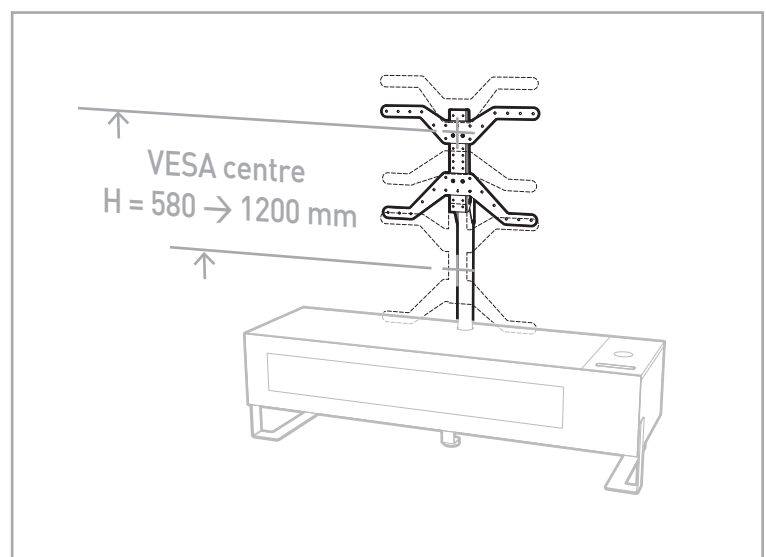

V1.2

POUR MEUBLE NAGA 1400/1600
FOR NAGA UNIT 1400/1600
FÜR MÖBEL NAGA 1400/1600
VOOR NAGA 1400/1600-MEUBILAIR
PER MOBILE NAGA 1400/1600
PAA MUEBLE NAGA 1400/1600

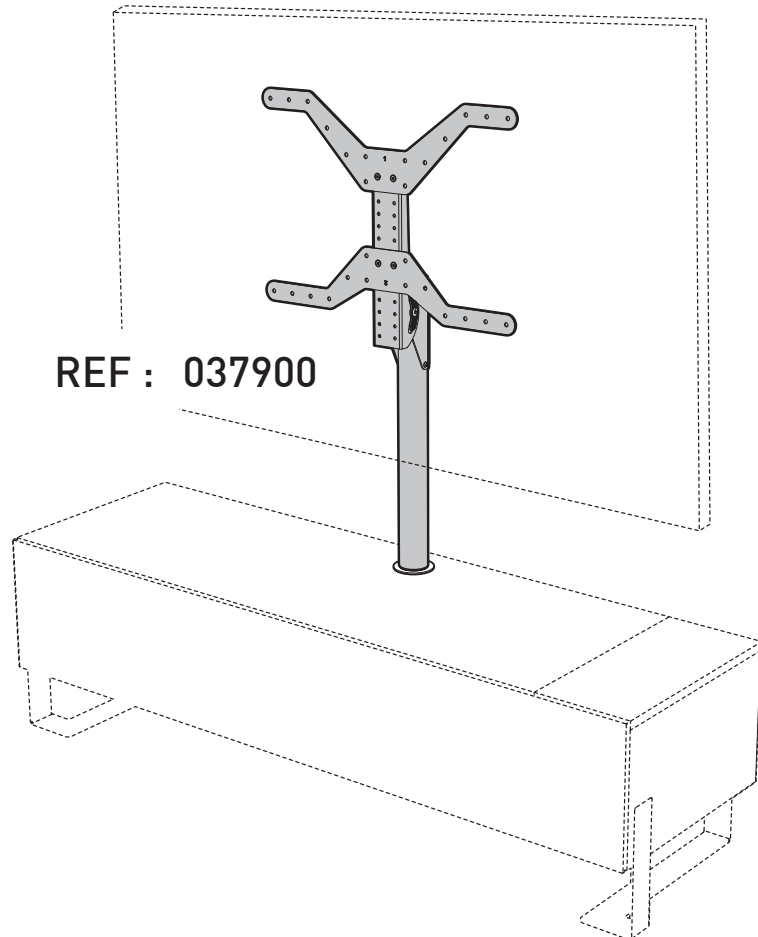

XL 40" - 75"
102-190cm

50 KG

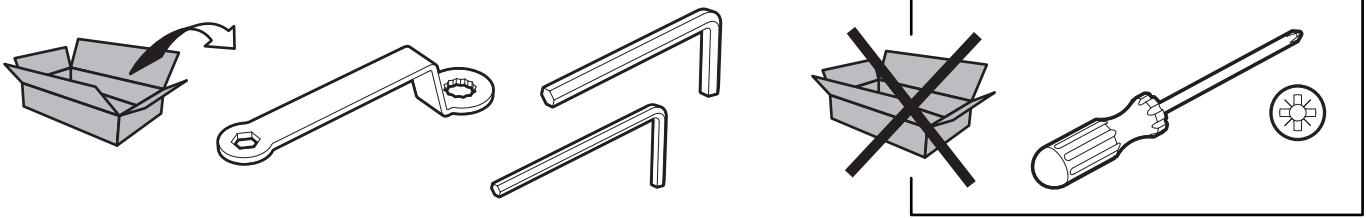

echelle- scale 1:1

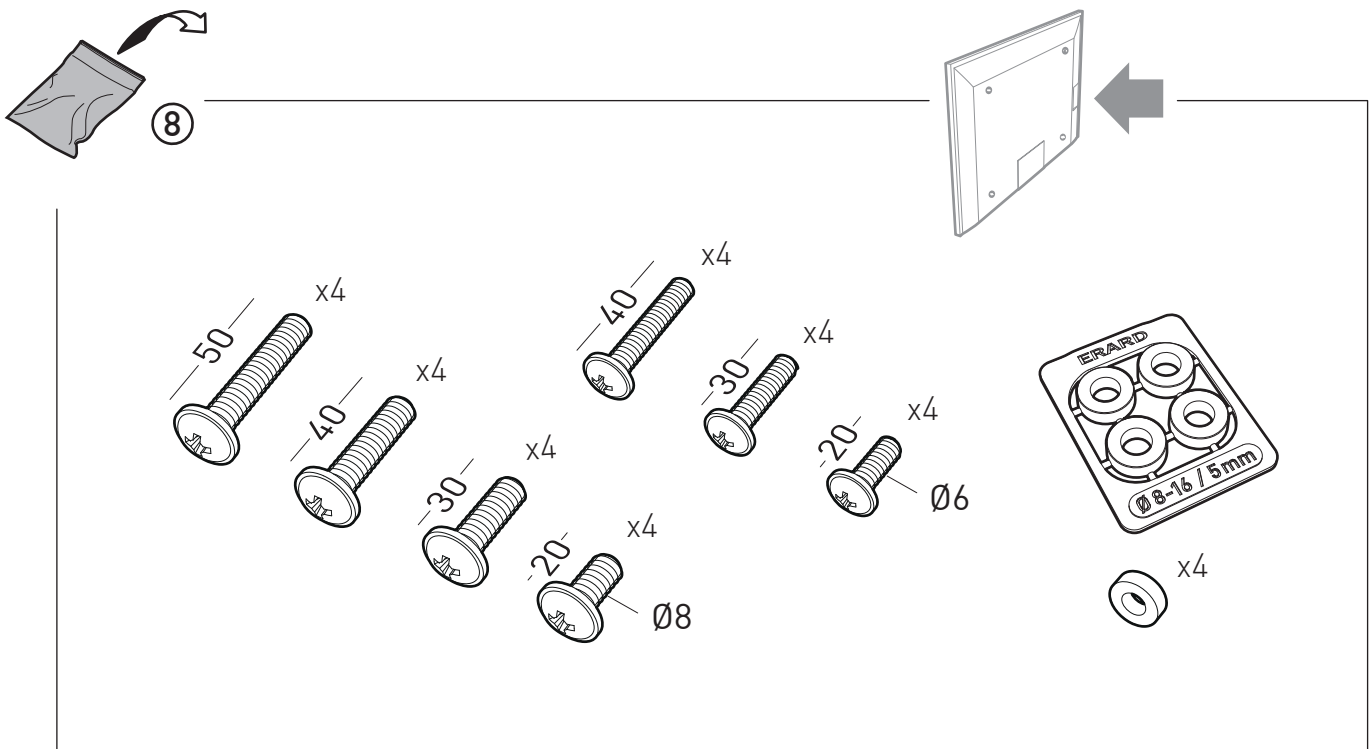
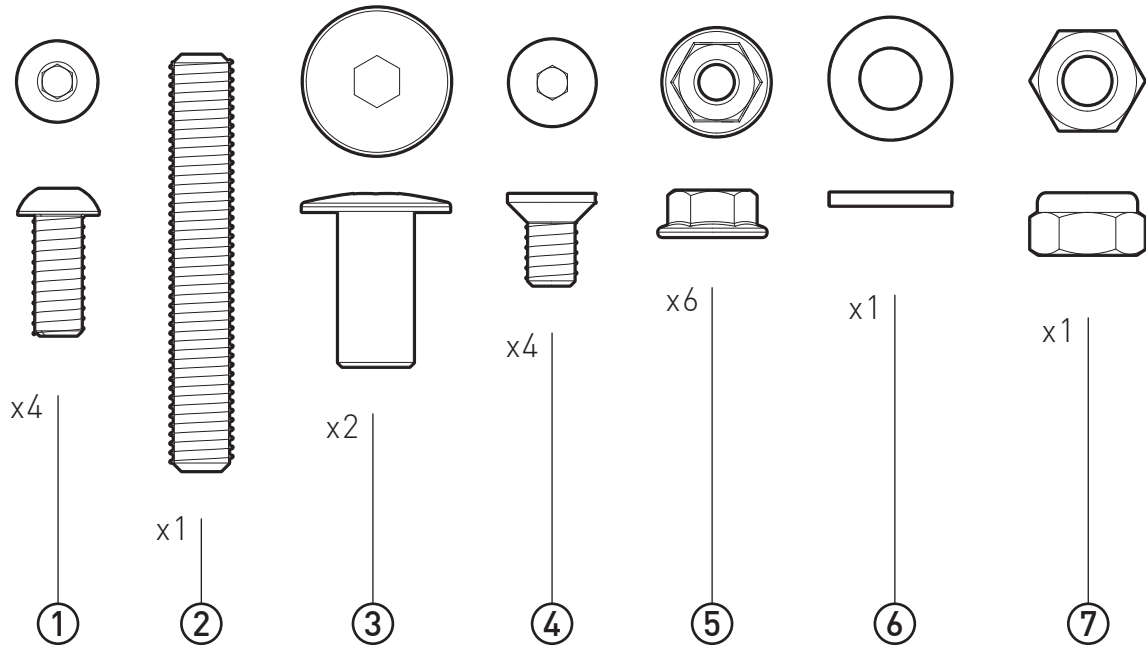

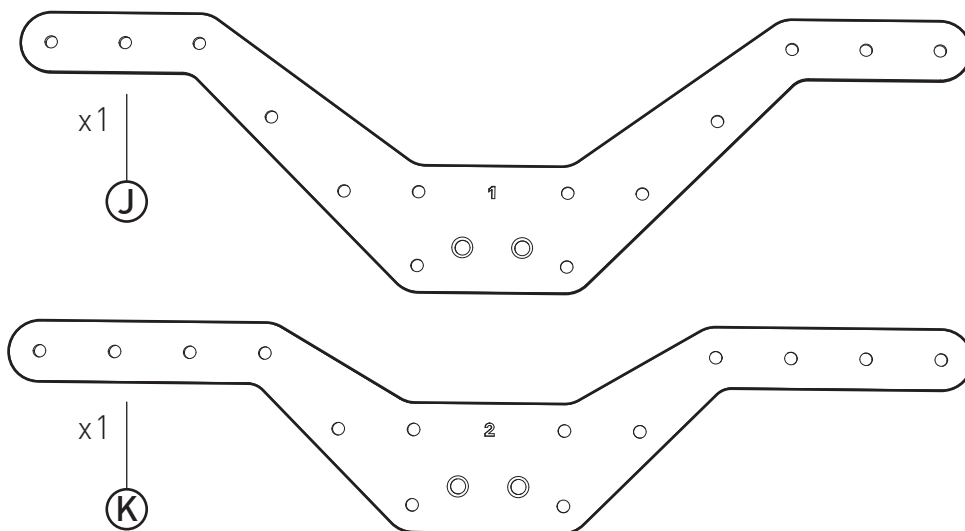
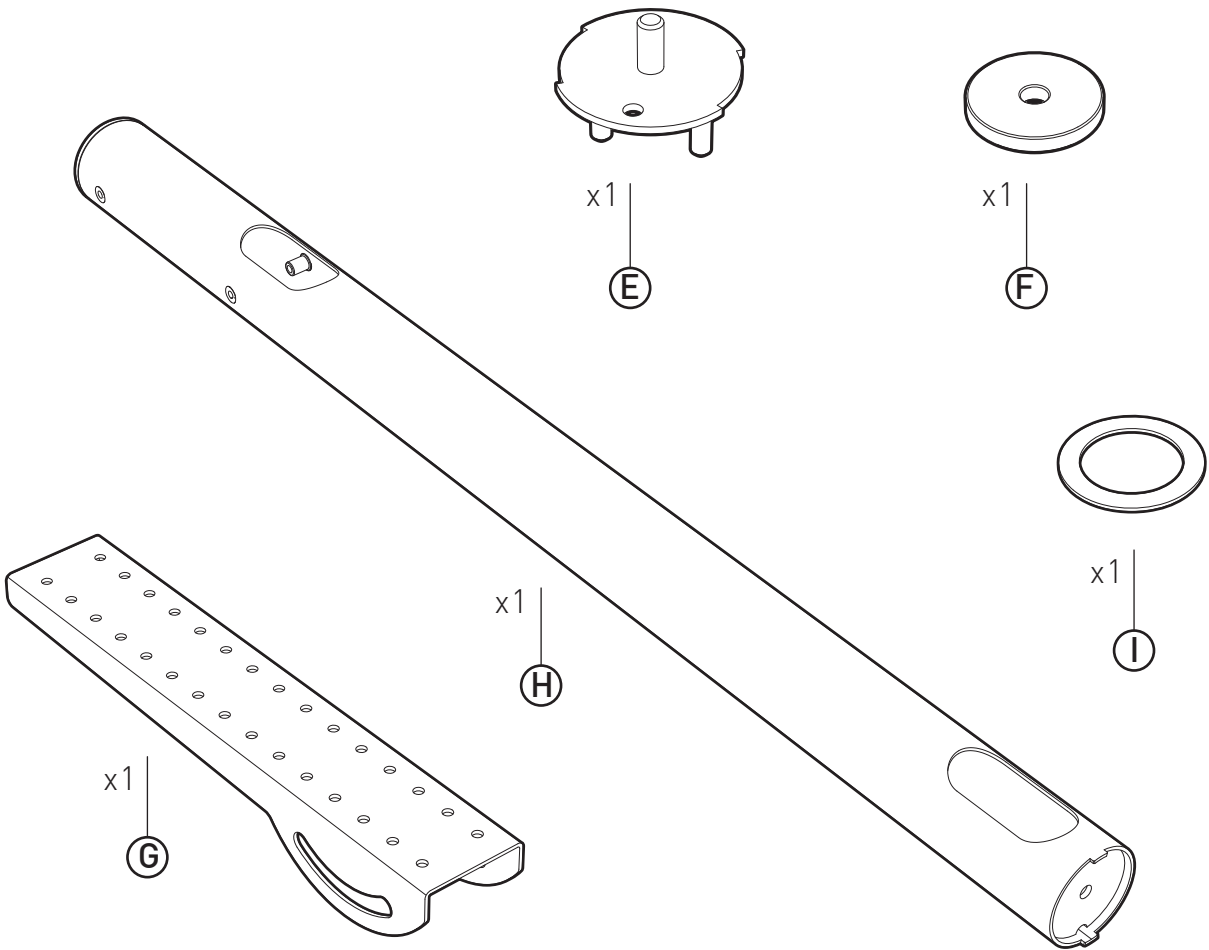
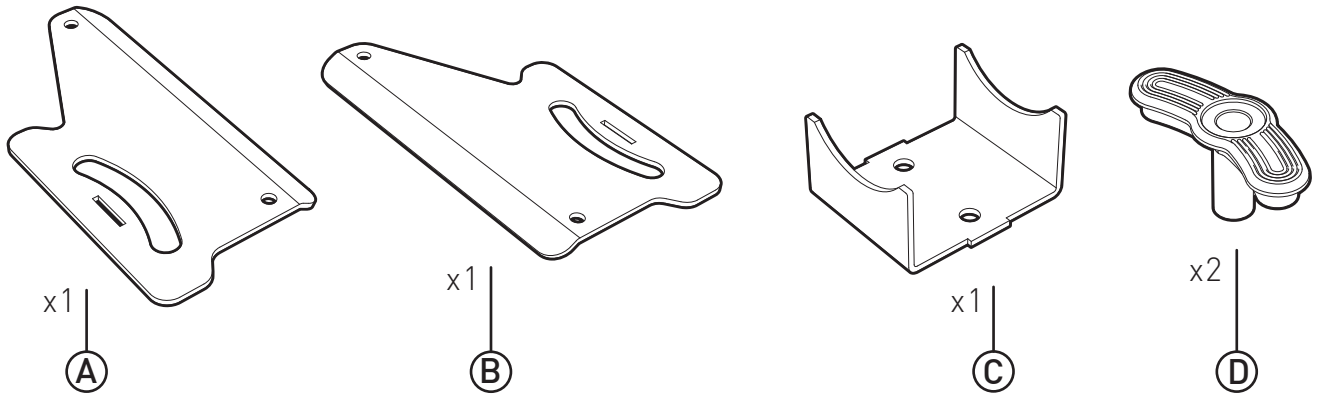

1

(A) + (B) + (C) + (1) x4

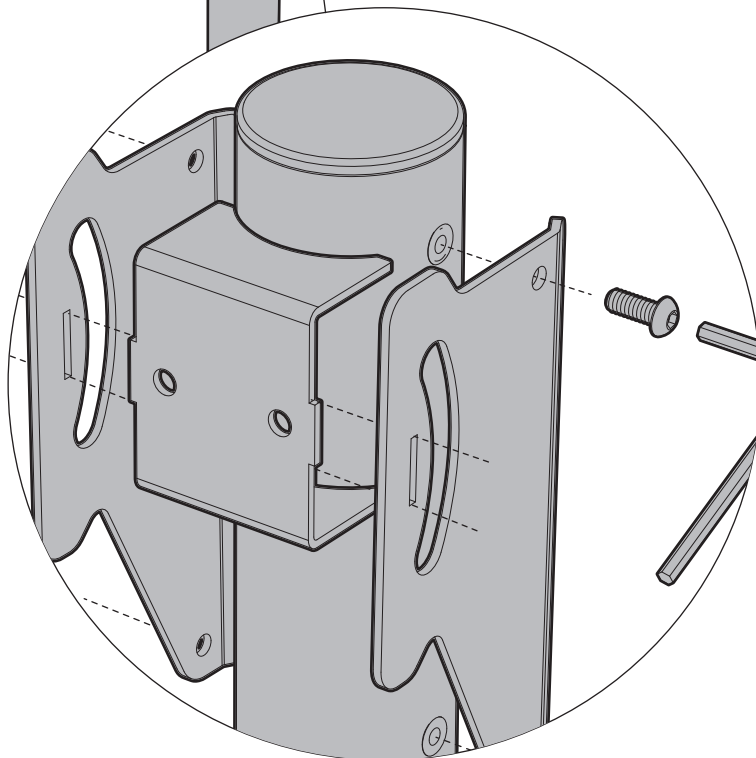
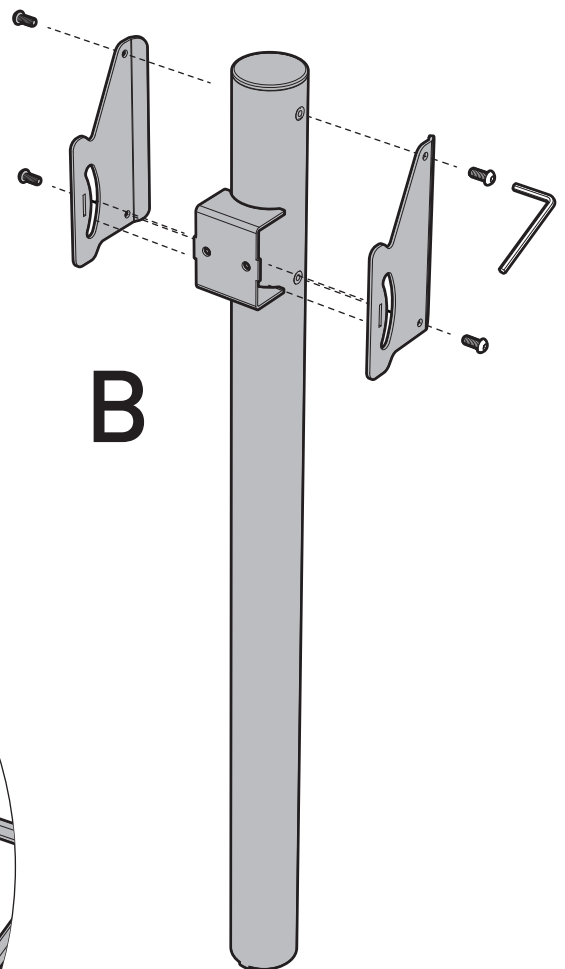
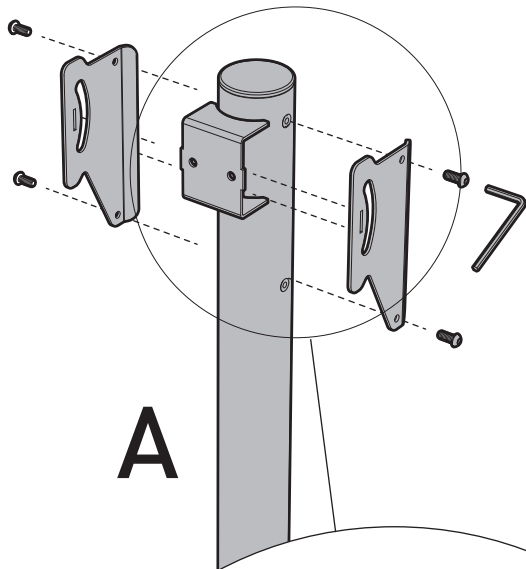
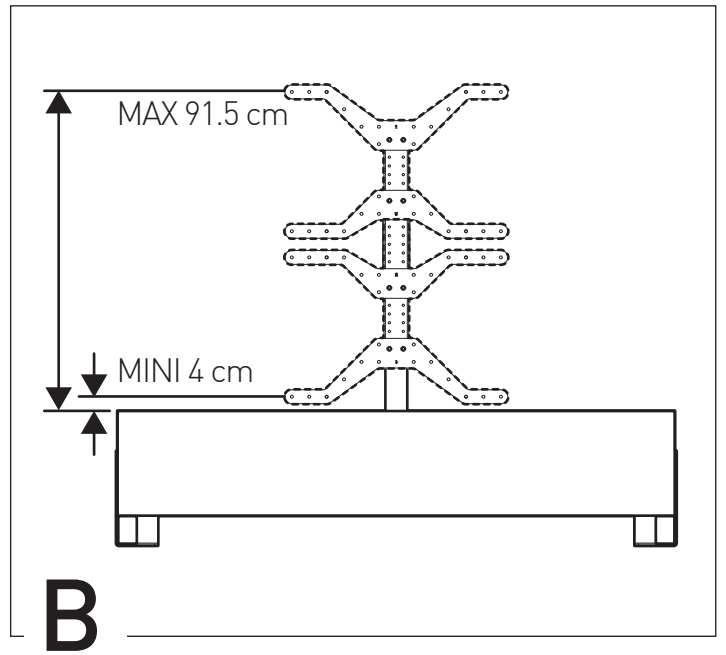
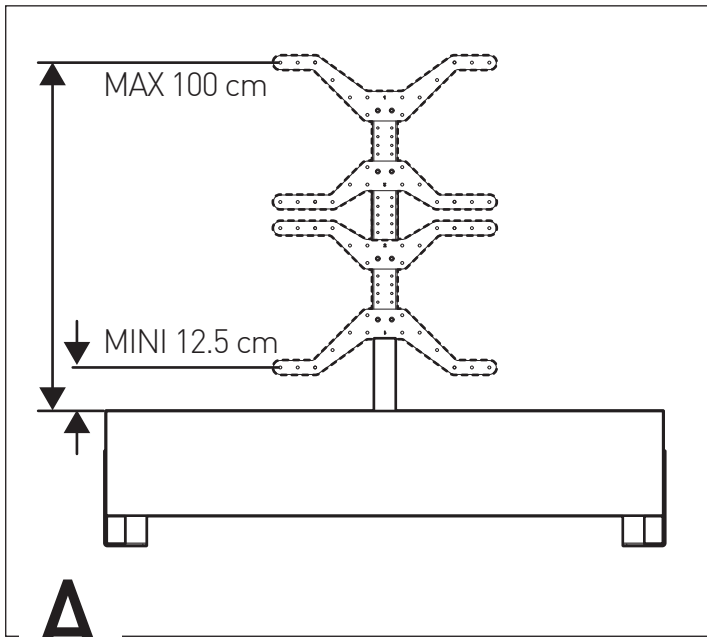

2 ⑥ + ④x2 + ② + ③x2

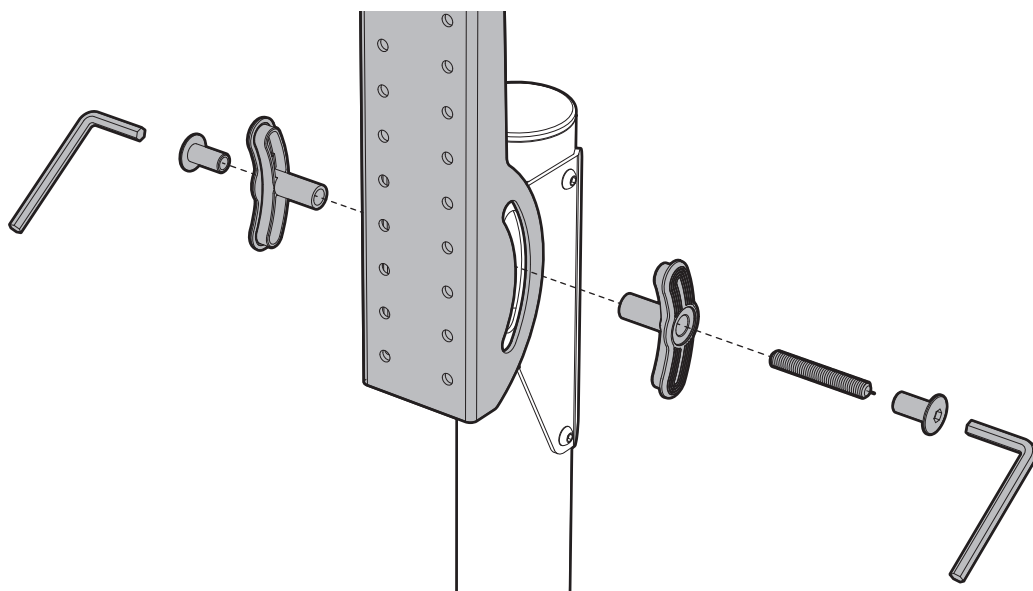
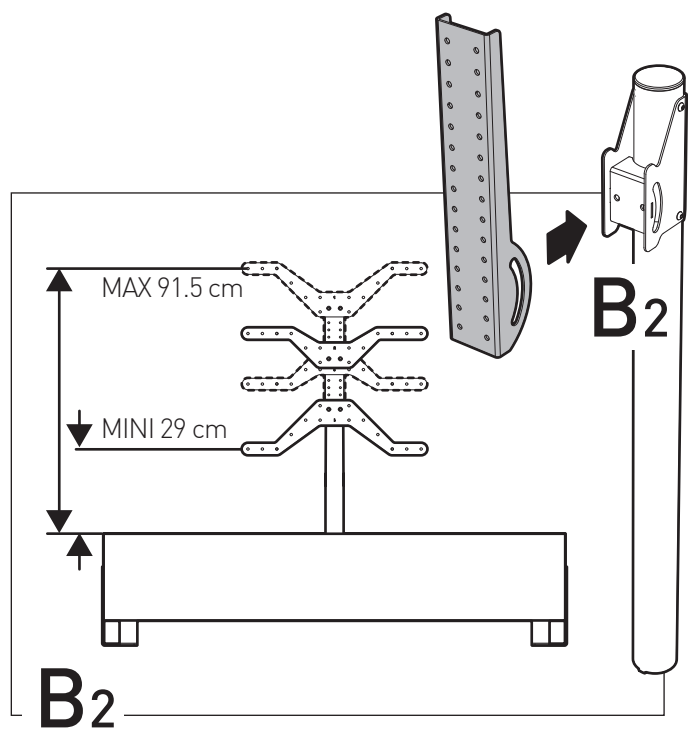
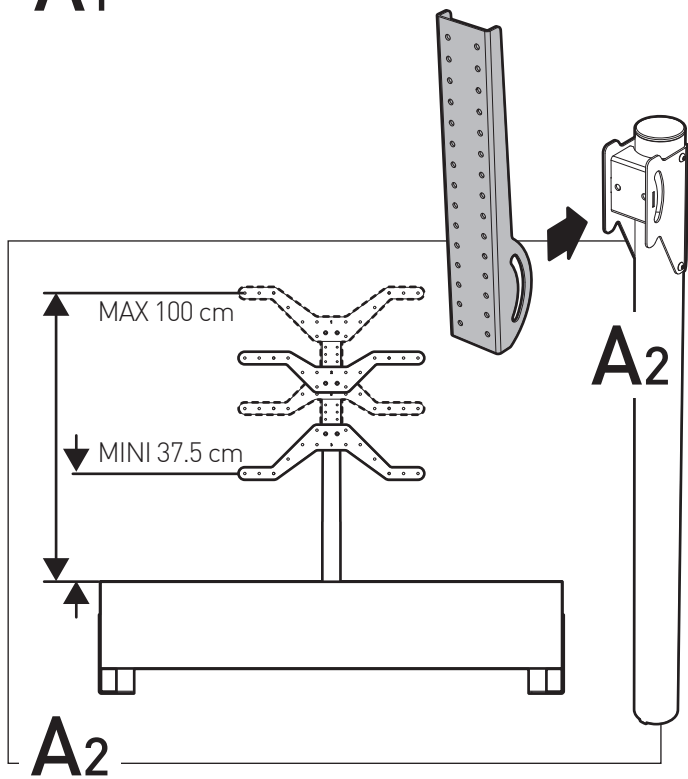
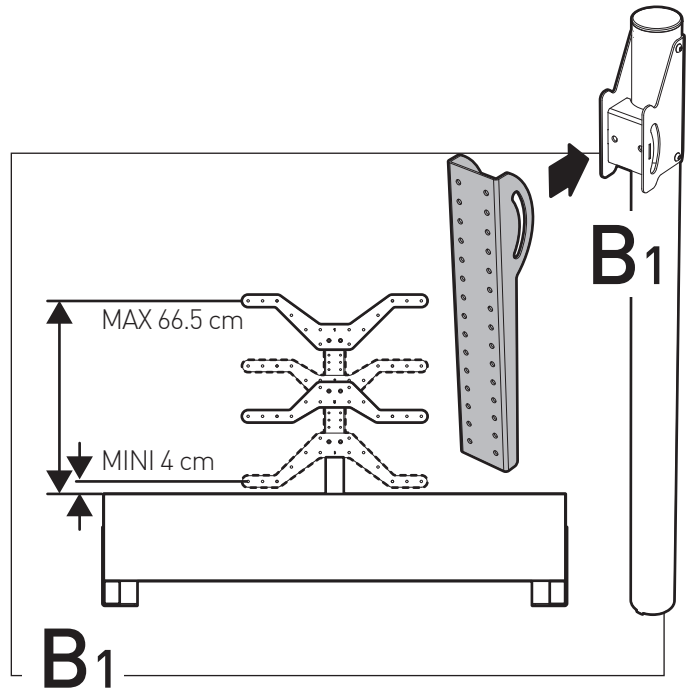
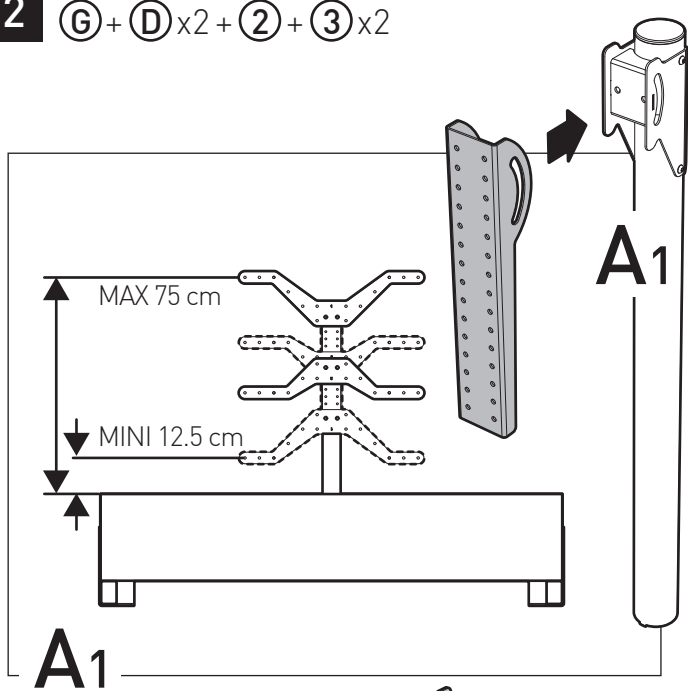

3

ⓐ + ⓑ + ④x4 + ⑤x4

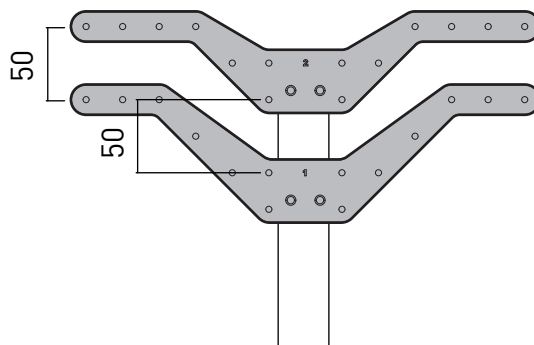
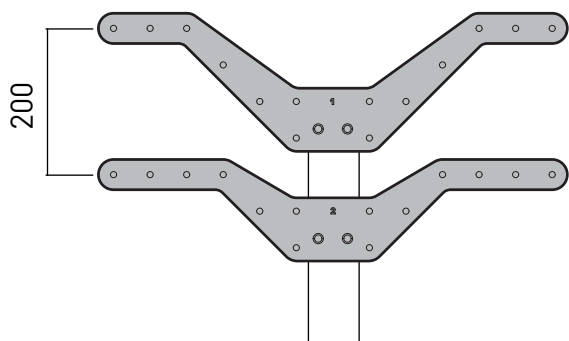
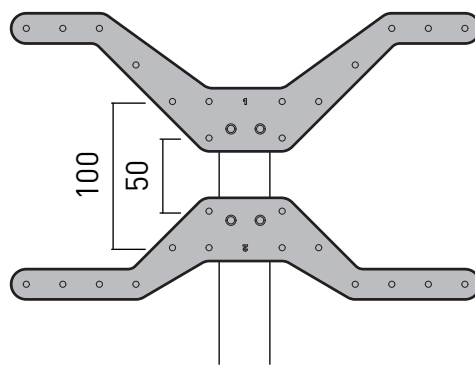
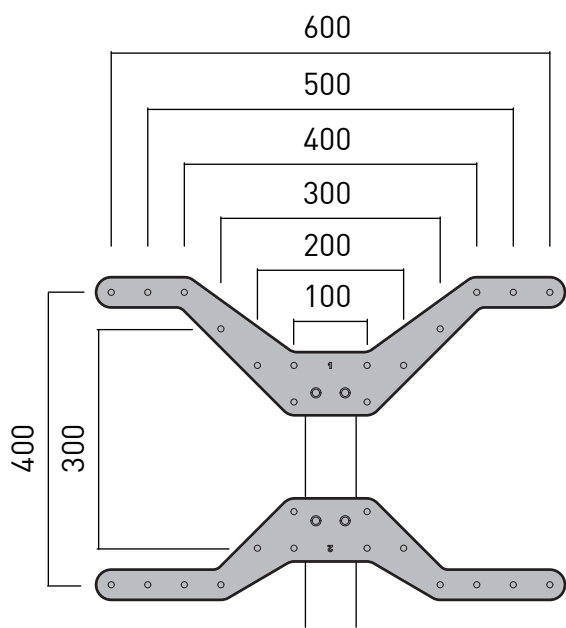
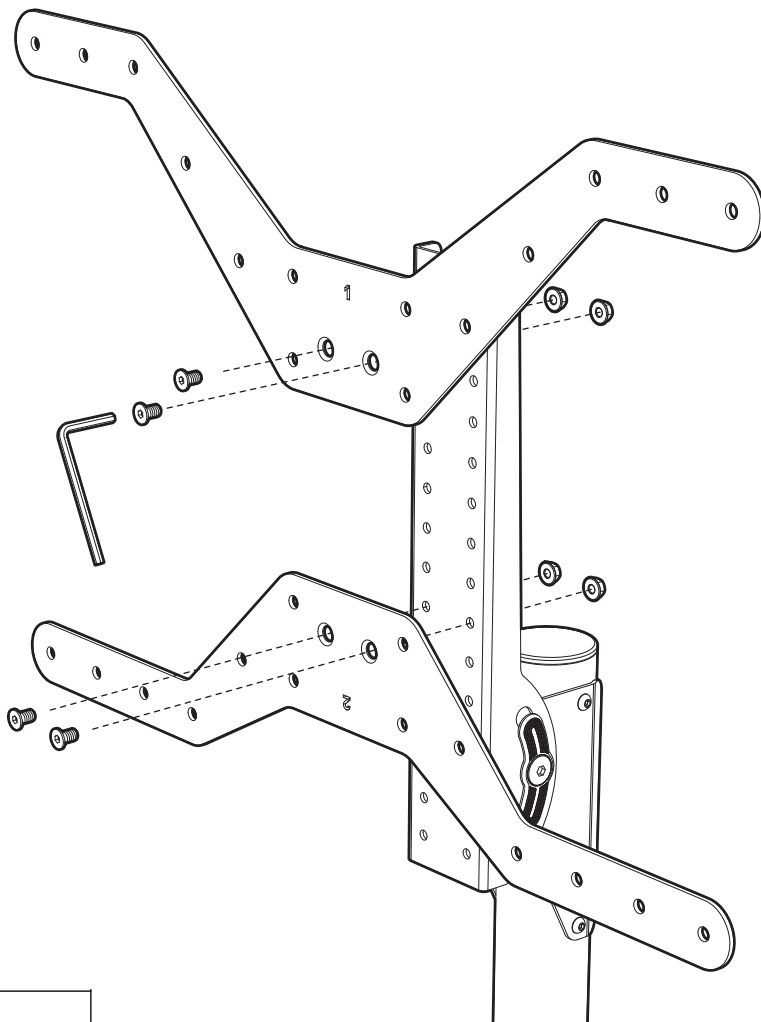

4 (E) + (F) + (5) x2

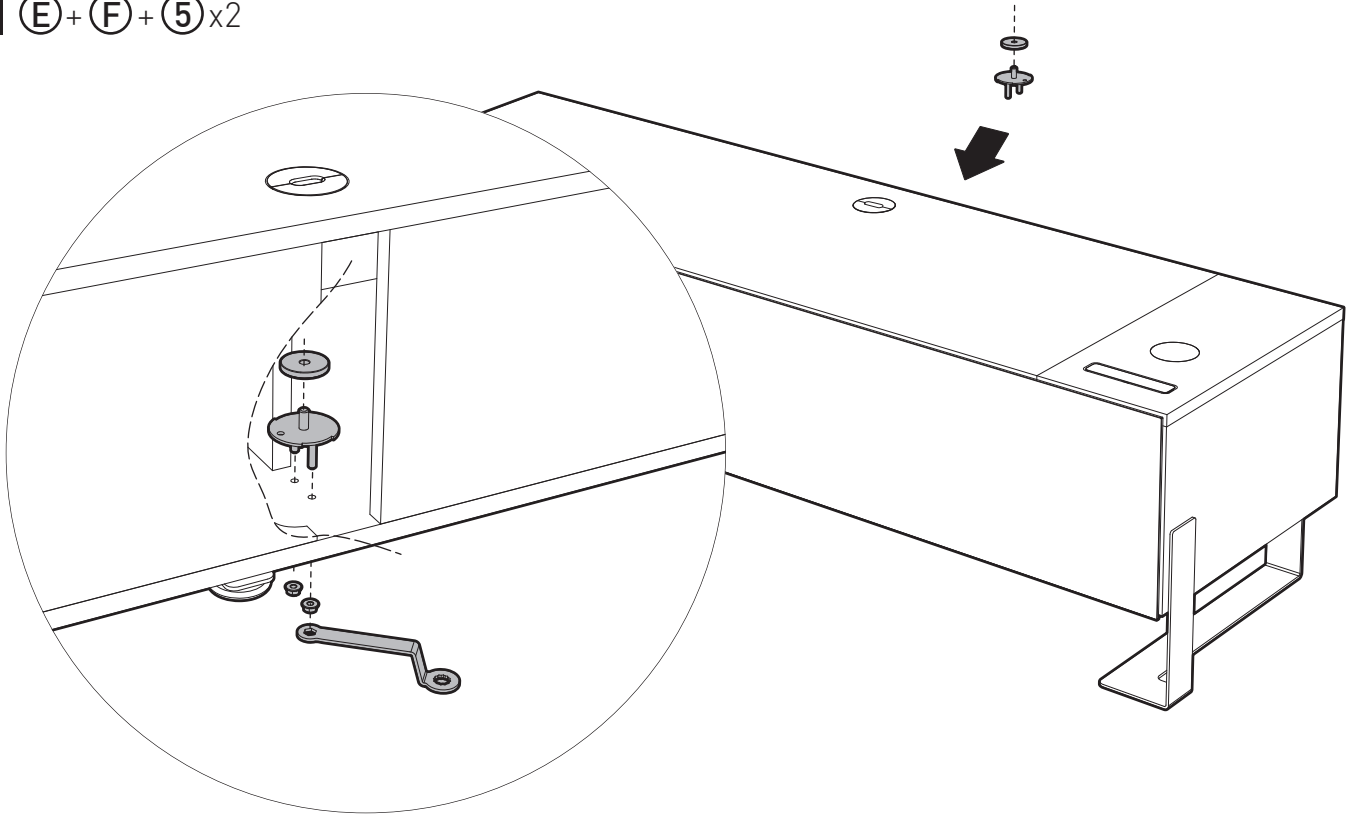

5 (1)

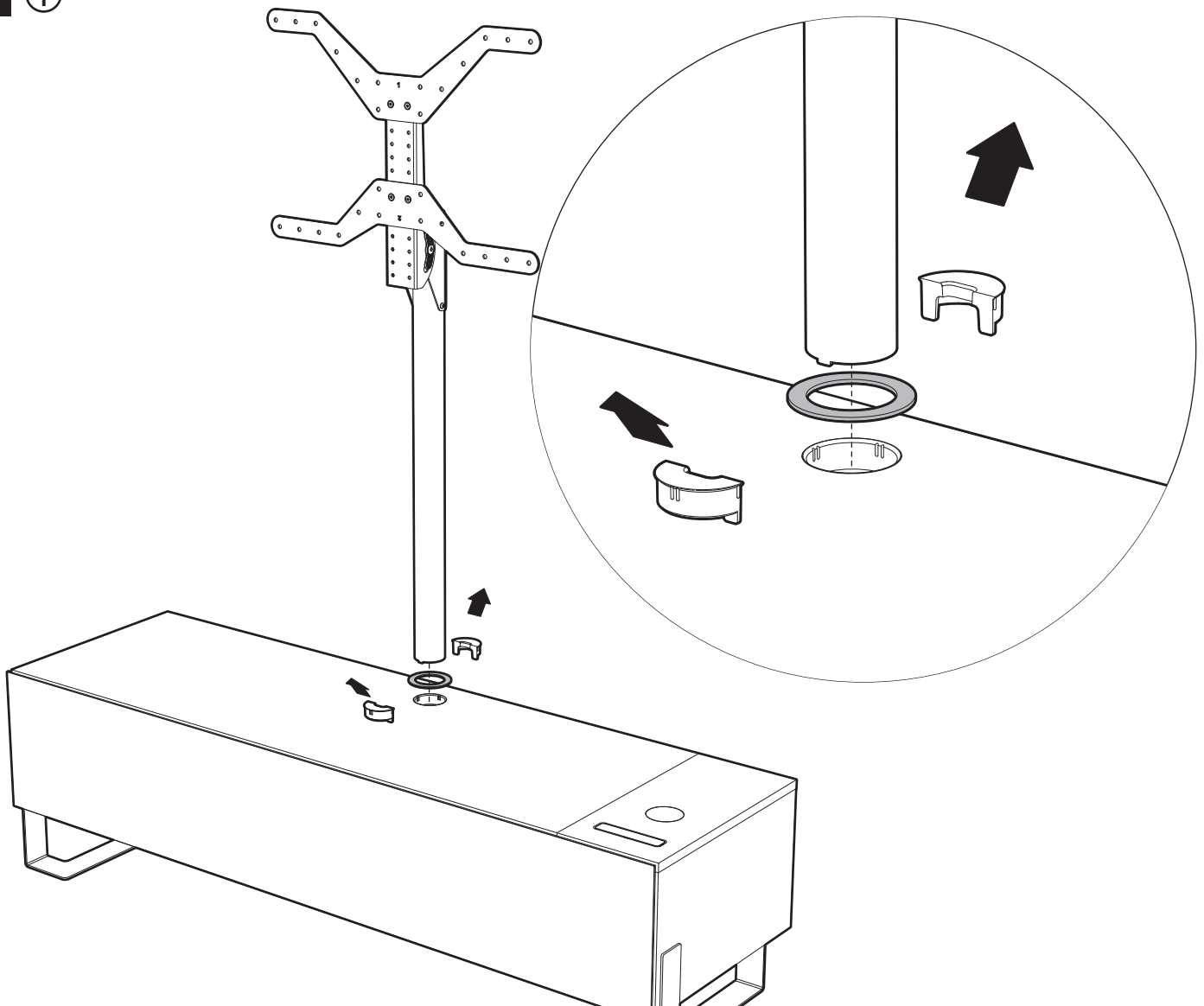

6 ⑥+⑦

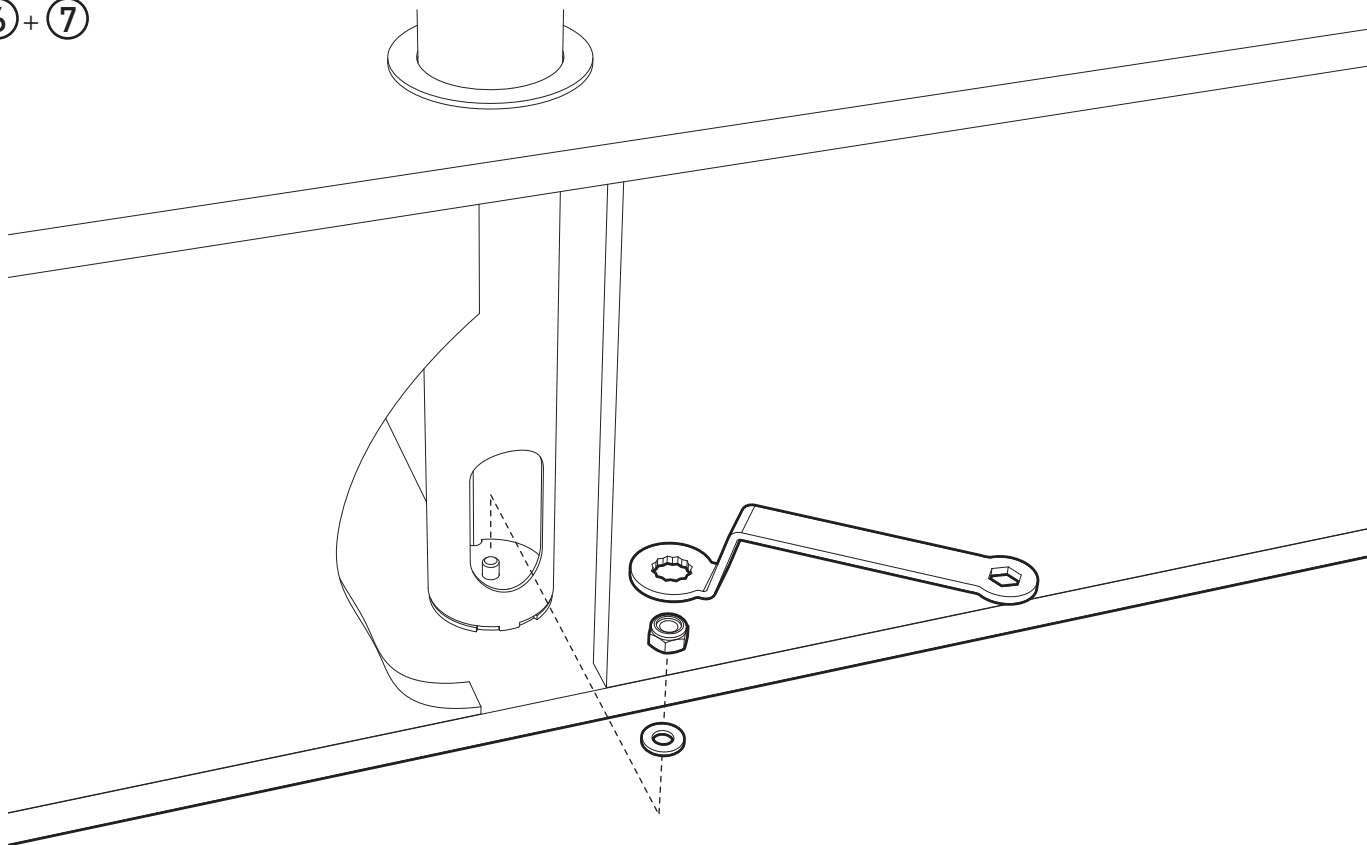

7

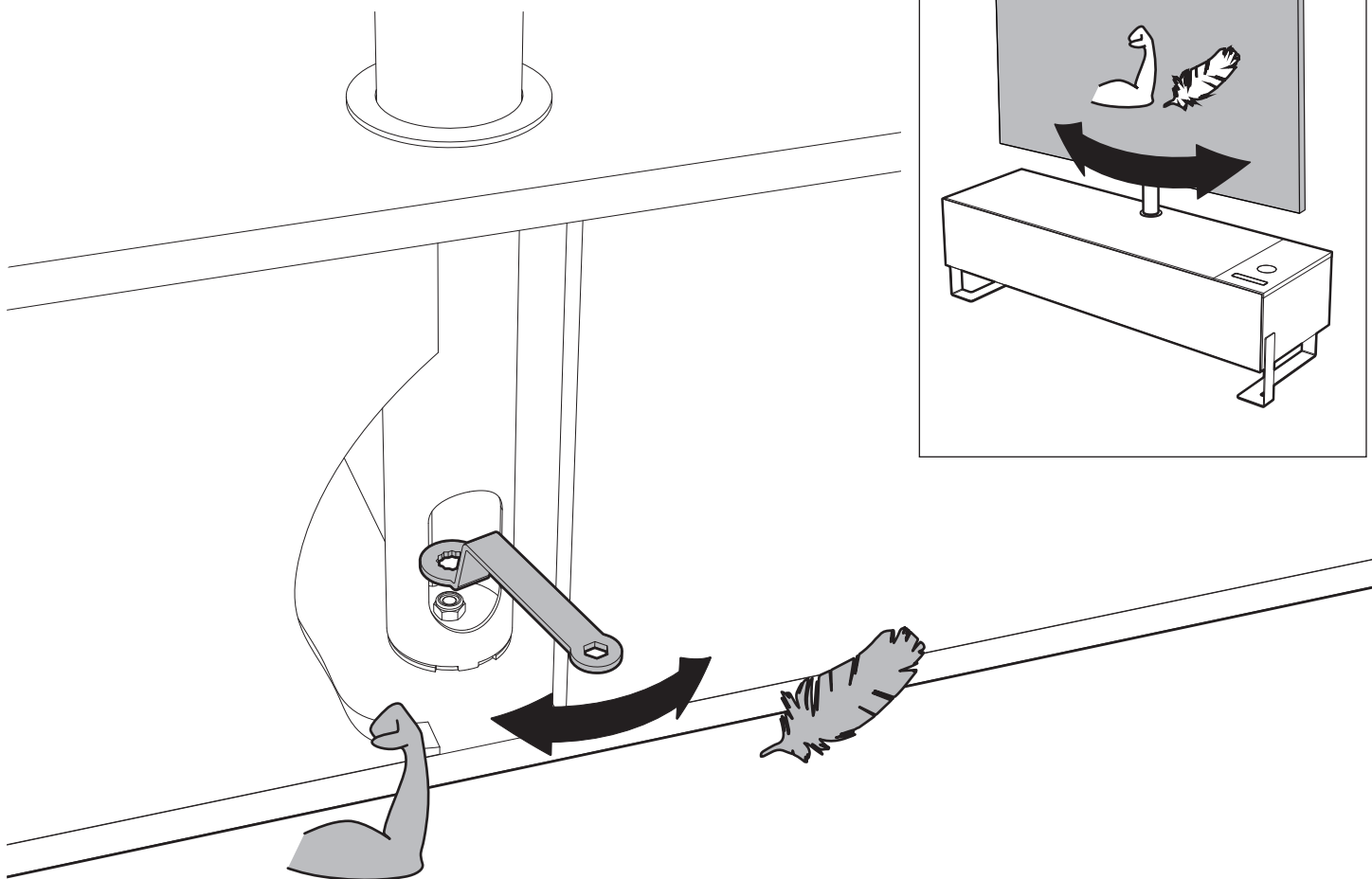

8

8

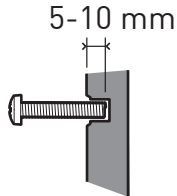
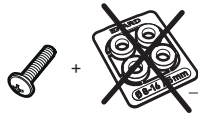
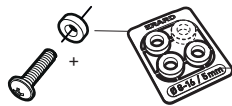
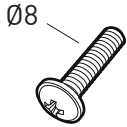
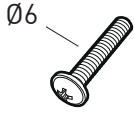
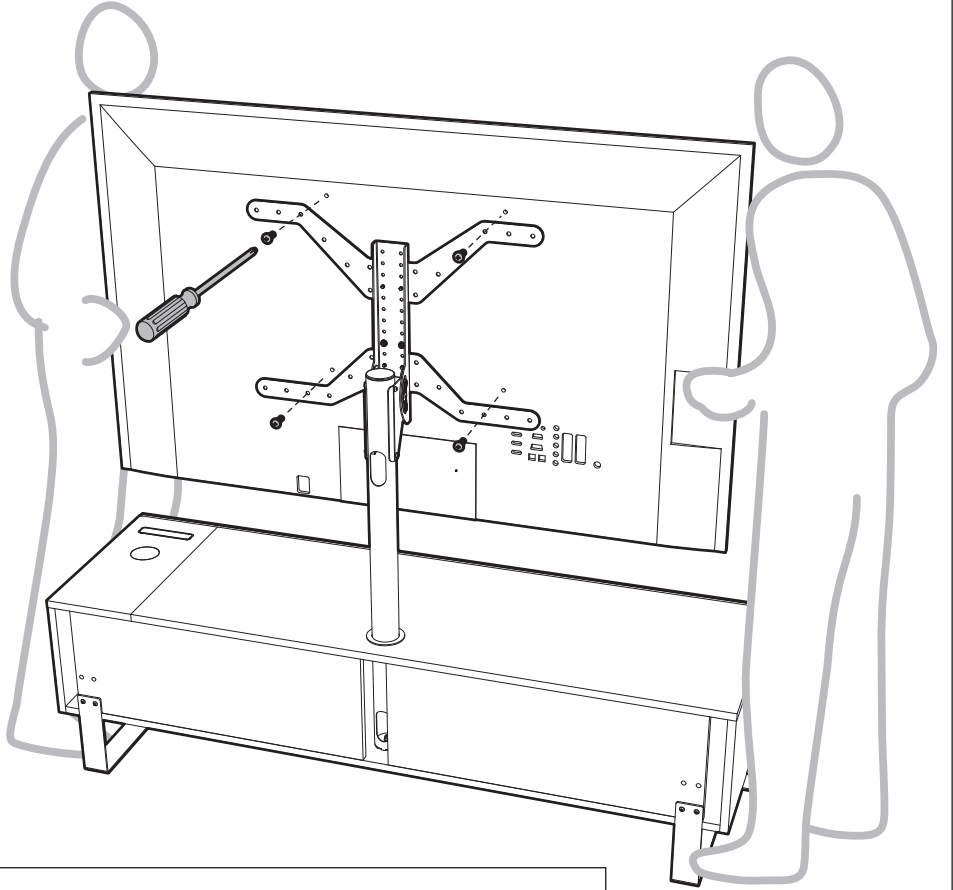
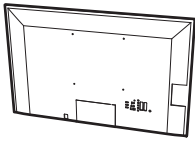

Ø6

Ø8



15 mm



20 mm



25 mm



30 mm



35 mm



40 mm



45 mm



50 mm

9

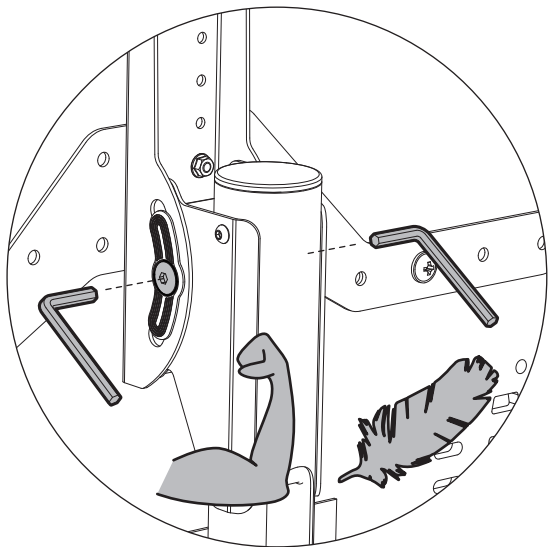
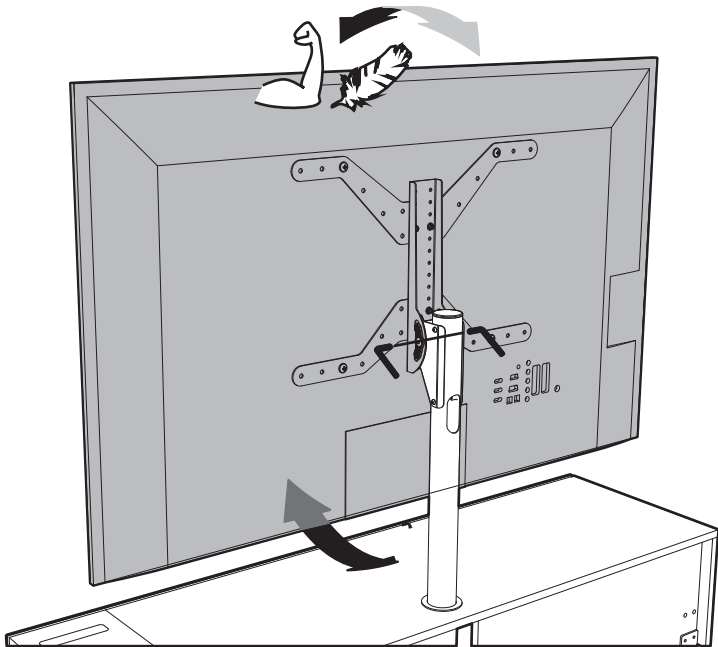

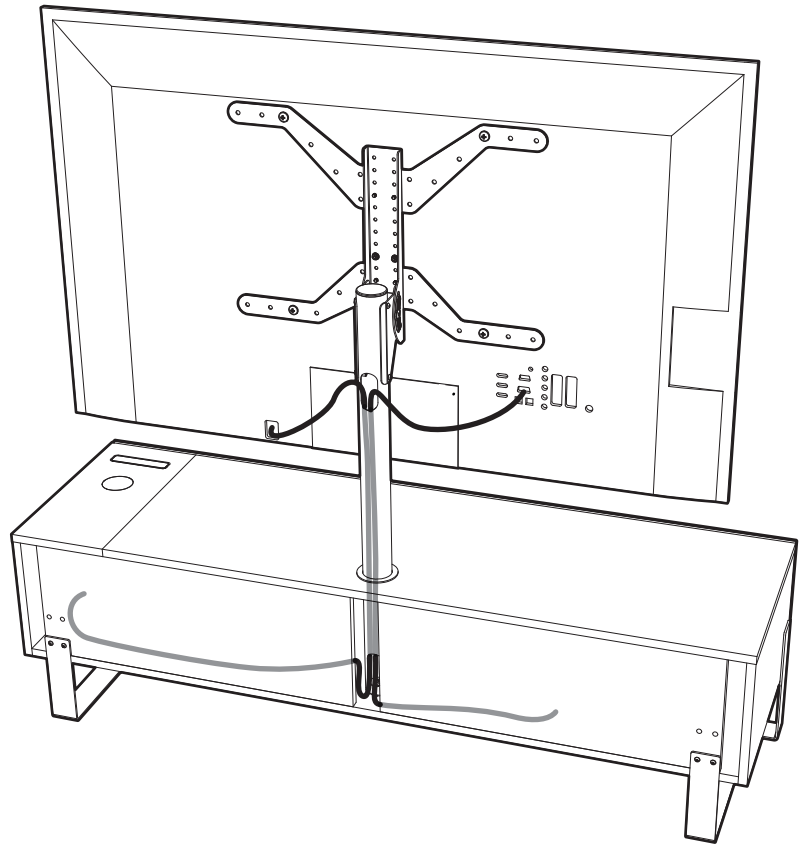

FR RECOMMANDATIONS D'ENTRETIEN

N'utiliser que de l'eau ou un produit nettoyant pour les vitres. Ne jamais utiliser un produit de nettoyage contenant de l'acétone, de l'essence ou de l'alcool ainsi que du White Spirit ou du diluant synthétique qui endommageraient le meuble.

GB CLEANING INSTRUCTIONS

Only use water or window cleaning product. Do not use cleaning solvent with acetone, oil, white spirit or synthetic thinner as these will damage the tv stand.

DE PFLEGE- ANLEITUNGEN

Benutzen nur Wasser oder Glasreinigungsmittel. Benutzen Sie keine azetonhaltigen, essenzhaltigen, alkoholhaltigen Reinigungsmitteln, Terpentinersatz oder synthetischen Auflösungsmitteln da Möbel beschädigen könnten.

NL REINIGINGS- INSTRUCTIES

Gebruik alleen een ruitenreiniger of water. Gebruik nooit producten op basis van aceton, benzine, terpentijn of andere synthetische verdunningsmiddelen, daar deze producten het meubel kunnen beschadigen.

IT RACCOMANDAZIONE DI MANUTENZIONE

Usa che l'acqua o un prodotto pulito per le vetri. Non mai utilizzare un prodotto di pulito contenenti dell'acetone, della benzina o dell'alcool o sole del Bianco spirito o del diluente Sintetiche.

ES INSTRUCCIONES DE LIMPIEZA

Utilizar solamente agua o producto para cristal. No utilizar productos a base de alcohol, acetona, esencia, aguarrás o sintético diluyente soluciones que dañarían el mueble.

FR GARANTIE

Votre meuble ERARD a été soumis à tous les essais requis et remplit toutes les exigences de sécurité applicables. Il est garanti 10 ans contre tout défaut de fabrication. Les modalités d'exercice de la présente garantie sont précisées dans les « conditions générales de vente » et dans la « charte SAV-garantie » (disponibles sur simple demande ou consultables sur le site www.erard.com).

Conditions de garantie

Pour bénéficier de cette garantie, vous devez contacter le service consommateur (numéro vert : 0 800 40 40 60) et leur transmettre une copie de la facture originale précisant la date d'achat, le nom du revendeur ainsi que le bon de garantie indiquant le type de produit et son numéro de série.

Toutefois, la garantie ne couvre pas les cas suivants :

- Dommages dus à une cause extérieure à l'appareil notamment foudre, chute du produit, dégât des eaux, incendie, etc.
- Usure normale du matériel.
- Frais d'acheminement ainsi que tout dommage durant le transport, liés à l'exécution de cette garantie.
- Dommages causés par négligence, détériorations dues au stockage, installation défectueuse, utilisations anormales, contraire ou non conforme aux recommandations de ce manuel, modifications, réparations effectuées par des personnes non mandatées par ERARD, etc.

Recyclage en fin de vie

Pour contribuer à la protection de l'environnement, utiliser les méthodes d'élimination et de récupération des emballages appropriées. Les cartons utilisés pour l'emballage de ce produit peuvent être recyclés ou réutilisés.

GB WARRANTY

Your ERARD tv stand has been subject to quality control and meets all of the applicable safety standards. It is guaranteed for 10 years against any manufacturing defect. For details of the warranty procedure, please refer to the "General Terms of Sale" and the "After Sales Warranty Charter" (available on request or viewable on www.erard.com).

Terms of Warranty

To benefit from this guarantee, please contact our customer service (toll-free number : +33 (0)4 72 46 16 26) and supply us with a copy of the original invoice showing the date of purchase and the name of the dealer, as well as the certificate of guarantee indicating the product type and the serial number. The guarantee does not cover the following :

- Damage caused by an external cause, namely lightning, dropping the product, water damage, fire, etc.
- Replacement of consumable parts
- Transport expenses as well as any damage occurred during the transport, associated with the validity of this guarantee.
- Damage resulting from negligence, damage due to poor storage conditions, inappropriate installation, abnormal use, contrary to or nonconforming with the recommendations stipulated in this manual, repairs carried out by persons without the authorisation of ERARD, etc.

End-of-life recycling

To help to protect the environment, use the appropriate recycling and discarding methods for the packaging. The boxes used for the packaging of this product may be recycled or re-used.

DE GARANTIE

Ihr Gebrauchsgut ERARD wurde den erforderlichen Prüfungen unterzogen und erfüllt alle geltenden Sicherheitsanforderungen. Es hat eine Garantie von 10 Jahren auf Herstellungsfehler. Die Modalitäten zur Inanspruchnahme dieser Garantie sind in den "Allgemeinen Verkaufsbedingungen" und in der "Kundenservice- und Garantie-Charta" festgelegt (die Sie jederzeit bei uns anfordern können und zudem auf unserer Website www.erard.com finden).

Garantiebedingungen

Um diese Garantie geltend zu machen, wenden Sie sich bitte an unseren Kundenservice (Anruf innerhalb Frankreichs kostenlos unter der: +33 (0)4 72 46 16 26) und schicken ihm eine Kopie der Originalrechnung mit dem Kaufdatum und dem Namen des Händlers sowie die Garantiekarte mit der Angabe des Produkttyps und der Seriennummer. Die folgenden Fälle sind von der Garantie jedoch nicht abgedeckt:

- Schäden aufgrund äußerer Ursachen, insbesondere Blitzschlag, Herunterfallen des Produkts, Wasserschäden, Brand usw.
- Normale Abnutzungerscheinungen des Produkts.
- Transportkosten sowie alle Transportschäden in Zusammenhang mit der Ausführung der Garantie.
- Schäden durch Nachlässigkeit, Lagerungsschäden, falsches Installieren, unsachgemäßen Gebrauch, Gebrauch im Widerspruch mit oder abweichend von den Empfehlungen dieses Handbuchs, Reparaturen durch nicht von ERARD befugte Personen usw.

Recycling am Lebensende

Aus Gründen des Umweltschutzes beachten Sie beim Entsorgen der Verpackung stets die örtlichen Vorschriften und Recyclingmöglichkeiten.

Die für die Verpackung dieses Produkts verwendeten Kartons können dem Recycling zugeführt und weiter verwertet werden.

IT GARANZIA

Il vostro mobile ERARD è stato sottoposto a tutti test richiesti e soddisfa tutti i requisiti di sicurezza applicabili. Il mobile è garantito 10 anni contro tutti i difetti di fabbricazione. Le modalità di esercizio della presente garanzia sono precisate nelle "condizioni generali di vendita" e nel "contratto garanzia-SAV" (disponibile su richiesta o consultabile al sito www.erard.com).

Condizioni di garanzia

Per usufruire di questa garanzia, occorre contattare il servizio consumatori (numero verde: +33 (0)4 72 46 16 26) ed inoltrargli una copia della fattura originale precisando la data di acquisto, il nome del rivenditore nonché il buono di garanzia indicante il tipo di prodotto e il relativo numero di serie.

Tuttavia, la garanzia non copre i seguenti casi:

- Danni dovuti ad una causa esterna all'apparecchio, nella fattispecie, fulmine, caduta del prodotto, danni da acqua, incendio, ecc.
- Usura normale del materiale.
- Spese di inoltro e qualunque danno durante il trasporto, correlati con l'esecuzione di questa garanzia.
- Danni causati da negligenza, deterioramenti dovuti all'immagazzinaggio, all'installazione difettosa, ad utilizzo anomalo, contrario o non conforme alle raccomandazioni del presente manuale, modifiche, riparazioni effettuate da persone non autorizzate da ERARD, ecc.

Riciclaggio a fine vita

Per contribuire alla salvaguardia dell'ambiente, procedere con metodi adeguati di smaltimento e di recupero degli imballaggi.

I cartoni usati per l'imballaggio di questo prodotto possono essere riciclati o riutilizzati.

NL GARANTIE

Uw ERARD-meubel werd onderworpen aan alle vereiste tests en voldoet aan alle toepasselijke veiligheidsnormen. Het meubel geniet een garantie van 10 jaar tegen fabricagefouten. De modaliteiten om gebruik te maken van deze garantie worden beschreven in de "algemene verkoopvoorwaarden" en in het "handvest inzake garantie en dienst na verkoop" (beschikbaar op aanvraag of op de website www.erard.com).

Garantievoorwaarden

Om van deze garantie te genieten, moet u contact opnemen met de klantendienst (gratis nummer: 0 800 40 40 60) en stuur hen een kopie van de originele factuur waarop de datum van aankoop, de naam van de dealer is vermeld en het garantieformulier met vermelding van het type product en het serienummer. De garantie dekt echter niet de volgende gevallen:

- Schade veroorzaakt door een externe oorzaak, zoals blikseminslag, vallen van het product, waterschade, brand, enz.
- Normale slijtage van de apparatuur.
- Verzendkosten en eventuele schade tijdens transport in verband met de uitvoering van deze garantie.
- Schade veroorzaakt door nalatigheid, verslechtering door opslag, verkeerde installatie, abnormaal gebruik, in strijd met of niet in overeenstemming met de aanbevelingen in deze handleiding, wijzigingen, reparaties uitgevoerd door personen die niet bevoegd zijn door ERARD, enz.

Recycling aan het einde van de levensduur

Gebruik geschikte afvoerings- en recyclingmethoden voor verpakkingen om het milieu te beschermen.

Dozen die worden gebruikt om dit product te verpakken, kunnen worden gerecycled of opnieuw worden gebruikt.

ES GARANTIA

Su mueble ERARD se sometió a todas las pruebas requeridas y cumple con todos los requisitos de seguridad aplicables. Tiene una garantía de 10 años contra cualquier defecto de fabricación. Las modalidades de ejercicio de la presente garantía se especifican en las condiciones generales de venta y en la "carta SAV-garantía" (disponibles mediante pedido o en la página web www.erard.com).

Condiciones de garantía

Para beneficiarse de esta garantía, debe ponerse en contacto con el servicio de atención al cliente (número gratuito: +33 (0)4 72 46 16 26) y enviarle una copia de la factura original en la que conste la fecha de compra y el nombre del vendedor así como la ficha de garantía que indique el tipo de producto y su número de serie. La garantía no cubre los casos siguientes:

- Daños producidos por una causa ajena al aparato sobre todo rayos, caída del producto, inundación, incendio, etc.
- Desgaste normal del material.
- Los gastos de envío así como cualquier año sufrido durante el transporte, vinculados a la ejecución de esta garantía.
- Daños causados por negligencia, deterioros producidos por el almacenamiento, instalación defectuosa, utilizaciones anormales, contrarias o que no cumplan las recomendaciones de este manual, modificaciones, reparaciones efectuadas por personas no autorizadas por ERARD, etc.

Reciclaje al final de su vida útil

Para contribuir a la protección del medio ambiente, utilice los métodos de eliminación y de reciclaje apropiados para los embalajes.

Las cajas utilizadas para el embalaje de este producto pueden reciclarse o reutilizarse.

WWW.ERARD.COM



VOUS AVEZ BESOIN DE CONSEILS?
YOU NEED HELP ?

N° Vert 0 800 40 40 60

APPEL GRATUIT DEPUIS UN POSTE FIXE

INTERNATIONAL : +33(0) 472 46 16 26

CONÇU EN FRANCE / FABRIQUÉ EN EUROPE (UE)
DESIGNED IN FRANCE / MADE IN EUROPE (EU)

