



PLAQUE
GARANTIE
À VIE

structure
garantie
2 ans

ORIGINE
FRANCE
GARANTIE

CERTIgaz

Plancha Enosign 65

- 1 - Hauts rebords
- 2 - 2 brûleurs circulaires en fonte
- 3 - Bac récupérateur à niveau 0,7L
- 4 - 2 manettes de commande
- 5 - 4 pieds réglables

Chariot

- 6 - Tablettes coulissantes
- 7 - 2 roues tout terrain
- 8 - 2 roues pivotantes avec frein
- 9 - 1 porte - poignée aluminium
- 10 - Capot - charnières à frein

COMBO ENOSIGN 65 noir & inox

REF: 57028385
EAN: 3224780041245



6/8

4,8 KW

Surface cuisson : 56 x 40 cm

DESCRIPTION PRODUIT

- Plancha Enosign 65 gaz
- Structure acier galvanisé et inox qualité marine
- 2 tablettes
- 2 roues tout terrain – 2 roues directionnelles à frein
- 1 porte noire – poignée aluminium porte ustensiles
- Capot de protection à frein
- Coloris noir & inox

LES OPTIONS

- Housse pop-up
HCI065

LIVRÉ PRÉ-MONTÉ

LES + PRODUIT

25%
ÉCONOMIE
ÉNERGIE

Éco-conception

DESIGN
SIGNATURE

BY
ENO

MATÉRIAUX
RÉSISTANTS

Inox de qualité
et acier galvanisé

ENTRETIEN
FACILE

Finitions
soignées



butane
propane
6 – 13 kg

COMBO ENOSIGN 65 noir & inox

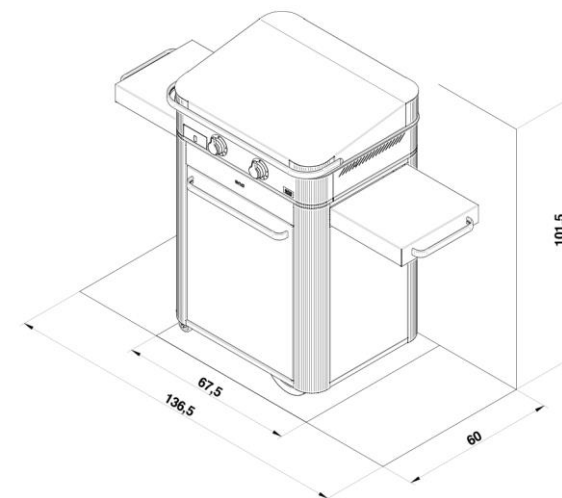

Code article	57028385
Gencode	3224780041245
Nom article	Combo ENOSIGN 65 cm Noir et Inox - Plancha Gaz sur Chariot
Description	Plancha gaz 2 brûleurs sur chariot
Nb Personnes	6/8
Surface cuisson	56 x 40cm / 22,05" x 17,75"
Homologation	CE, ALIMENTAIRE, Longtime
Utilisation	Extérieur
Dim. Produit (H x L x P)	100 x 126 x 57 cm / 39,37" x 49,61" x 22,44"
Dim. emballage (H x L x P)	109 x 70 x 61 cm / 42,91" x 27,56" x 24,02"
Poids net	74,5 kg / 164,27 lbs
Poids Emballé	82 kg / 180,81 lbs
PCB	1
Nb colis/article	3
Nb pces/pal	14
Energie	Gaz butane / propane / gaz naturel
Type branchement	G1/2
Nb brûleurs	2
Puissance bruleurs kW	4,8 kW / 16378 BTU/h
Consommation	349 g/h
Allumage	Electronique 1 main
securité	thermocouple
Plaque	Fonte émaillée
Revêtement plaque	Email multicouche, finition lisse
Détails plaque	Rebords hauts à double paroi, goutte d'évacuation des jus
Châssis	Inox 304L et acier galvanisé thermolaqué
Protection	Finition marine et peinture polyester renforcée
Coloris	Poli et noir
Détails	Capot à frein, double paroi, 4 pieds réglables, tiroir récupérateur de jus en inox
Garanties: plaque, brûleurs, autres pieces	
Origine	Origine France Garantie
Ecotaxe DEEE HT	
Taxe Ecomobilier HT	0,25
Taux TVA	20%
Code douanier	73211190
Notice	85563.pdf,85559.pdf



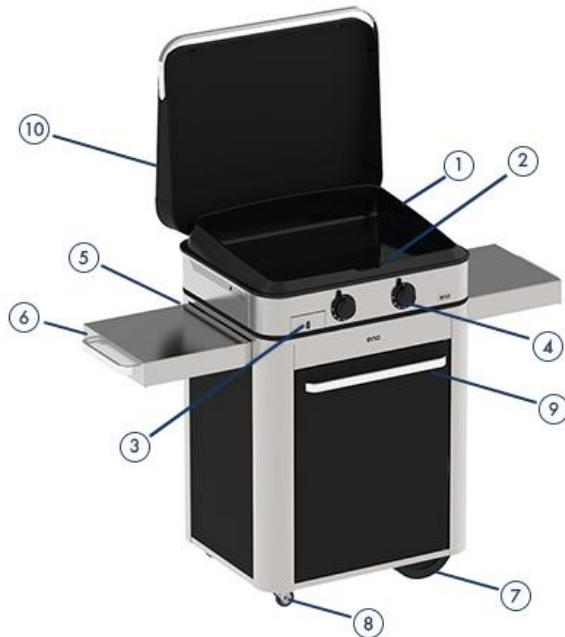

Plancha Enosign 65

- 1 - High edges
- 2 - 2 cast-iron ring burners
- 3 - Level recovery tray 0,7L
- 4 - 2 control buttons
- 5 - 4 adjustable feet

Trolley

- 6 - Sliding shelves
- 7 - 2 all-terrain wheels
- 8 - 2 swivel wheels with brakes
- 9 - 1 door - aluminium handle
- 10 - Lid - hinges with brake

plate
lifetime
warranty

structure
2 years
warranty



COMBO ENOSIGN 65 black & stainless

REF: 57028385
EAN: 3224780041245

6/8 | **4,8 KW**

Cooking surface : 56 x 40 cm

PRODUCT DESCRIPTION

- Plancha Enosign 65 gas
- Galvanised steel and marine-grade stainless steel structure
- 2 shelves
- 2 all-terrain wheels- 2 directional wheels with brake
- 1 black door – aluminium utensil holder handle
- Protective lid with brake
- Black & stainless color

OPTIONS

- Cover trolley
HCI065

DELIVERED PRE-ASSEMBLED

+ PRODUCT

25% ENERGY
SAVINGS

Eco-design

SIGNATURE
DESIGN

BY
ENO

RESISTANT
MATERIALS

Quality stainless steel
and galvanised steel

ESAY
TO CLEAN

Meticulous
finishes



butan
propan
6 – 13 kg

# article	57028385
Gencod	3224780041245
Article name	Combo ENOSIGN 65 cm Black/Stainless - Gas Griddle on Cart
Description	2 burners gas plancha on trolley
Capacity	6/8
Cooking Area	56 x 40cm / 22,05" x 17,75"
Certification	CE, FOOD CONTACT, Longtime_en
Usage	Outdoor
Product dim.(H x L x P)	100 x 126 x 57 cm / 39,37" x 49,61" x 22,44"
Packaging dim. (H x L x P)	109 x 70 x 61 cm / 42,91" x 27,56" x 24,02"
Net weight	74,5 kg / 164,27 lbs
Gross weight	82 kg / 180,81 lbs
Per outer	1
Nb box/SKU	3
Nb SKU/pal	14
Energy	Gas butan / propan / NG
Connexion	G1/2
Nb burners	2
Output	4,8 kW / 16378 BTU/h
Consumtion	349 g/h
Ignition	Electronic 1 hand
Safety	thermocouple
Plate	Cast enamelled plate
Plate coating	Smooth multilayer enamel
Plate details	High anti-splash and double wall rims, channel for recovering juices
Frame	Stainless steel 304L and galvanized steel coated
Coating	Marine finish and charged polyester paint
Colour	Polished and black
Details	Lid, double wall, 4 adjustable legs, stainless steel juice collector tray
Waranty	
Manufacturing origin	Origine France Garantie
User manual	85563.pdf,85559.pdf
Customs code	73211190

COMBO ENOSIGN 65 black & stainless

