



# Farelek



## Tennessee

FR	Ventilateur sur pied (Notice originale)
EN	Free-standing fan (Original manual translation)
DE	Standventilator (Übersetzung aus dem Original-Anleitung)
ES	Ventiladores de pie (Traducción del manual de instrucciones originale)
IT	Ventilatori su piedi (Traduzione dell'avvertenza originale)
PT	Ventiladores de pé (Tradução do livro de instruções original)
NL	Staaende ventilator (Vertaling van de originele instructies)
EL	ΑΝΕΜΙΣΤΗΡΕΣ ΜΕ ΠΟΔΙ (ΜΕΤΑΦΡΑΣΗ ΑΠΟ ΤΙΣ ΠΡΩΤΟΤΥΠΕΣ ΟΔΗΓΙΕΣ)
PL	Wentylatory stojące (Tłumaczenie z oryginalnej instrukcji)
FI	Jaloilla seisovat ilmastointilaitteet (Käännös alkuperäisestä ohjeet)
SV	Golvfläktar (Översättning från originalinstruktioner)
BG	Вентилатор за таван (Превод на оригиналната инструкция)
DA	Loftventilator (Oversættelse fra oprindelige brugsanvisning)
RO	Ventilator (Traducere din instrucțiunile originale)
RU	Вентиляторы на стойка (Перевод с оригинальной инструкции)
TR	Taban vantilatörü (Orijinal talimatlar çeviri)
CS	Ventilátor s podstavcem (Překlad z originálního návodu)
SZ	Nožné ventilátory (Preklad z originálneho návodu)
HE	תורוקמ תוארוהמ סוגרת) מאוורר על בסיס
AR	قيلصلأال تاميلعلل نم قمجرتلل) مُدوُحَة تهووية على ركنية
HU	Talpaszos ventilátor (Fordítás az eredeti utasítások)
SL	Ventilatorji na stojalu (Prevod iz izvornih navodil)
EE	Ringventilaator (Tõlge originaal juhiseid)
LV	Švytuojantis ventilatorius (Tulkojumā no instrukcijas oriģinālvalodā)
LT	Svarstigais ventilators (Vertimas iš originalių instrukcijas)
HR	Ventilator na postolju (originalne upute)



© FAR GROUP EUROPE

112100-4-I-20251001



# fartools.com





Description et repérage des organes de la machine  
Description and location of machine parts

# A

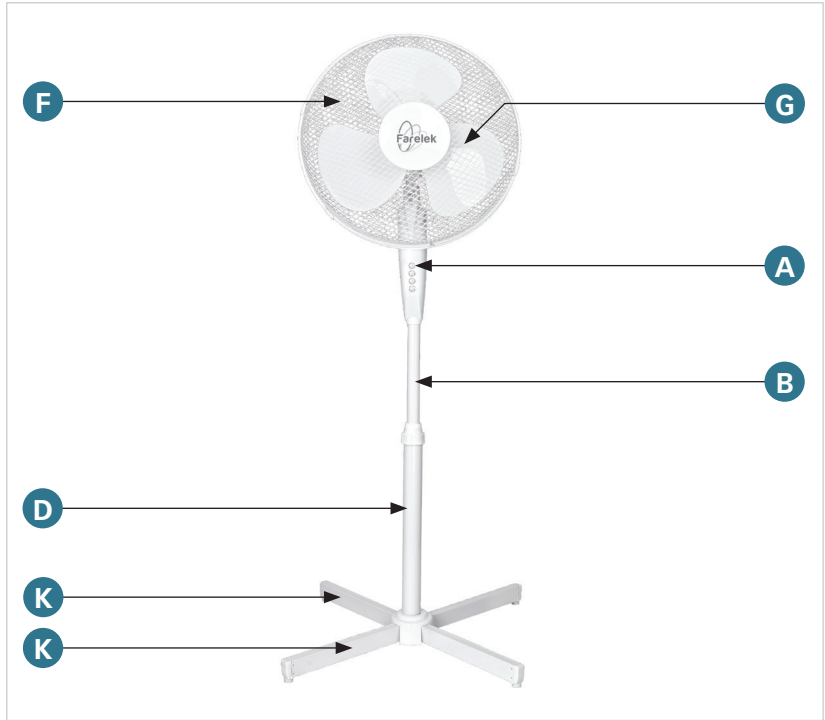

Contenu du carton  
Contents of box

# C

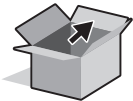

A DÉPOSER EN MAGASIN  
A DÉPOSER EN DÉCHÈTERIE  
OU

Points de collecte sur [www.quefairedesdechets.fr](http://www.quefairedesdechets.fr)  
Privilégiez la réparation ou le don de votre appareil !





Assemblage de la  
machine  
Machine assembly

**D**

**01**

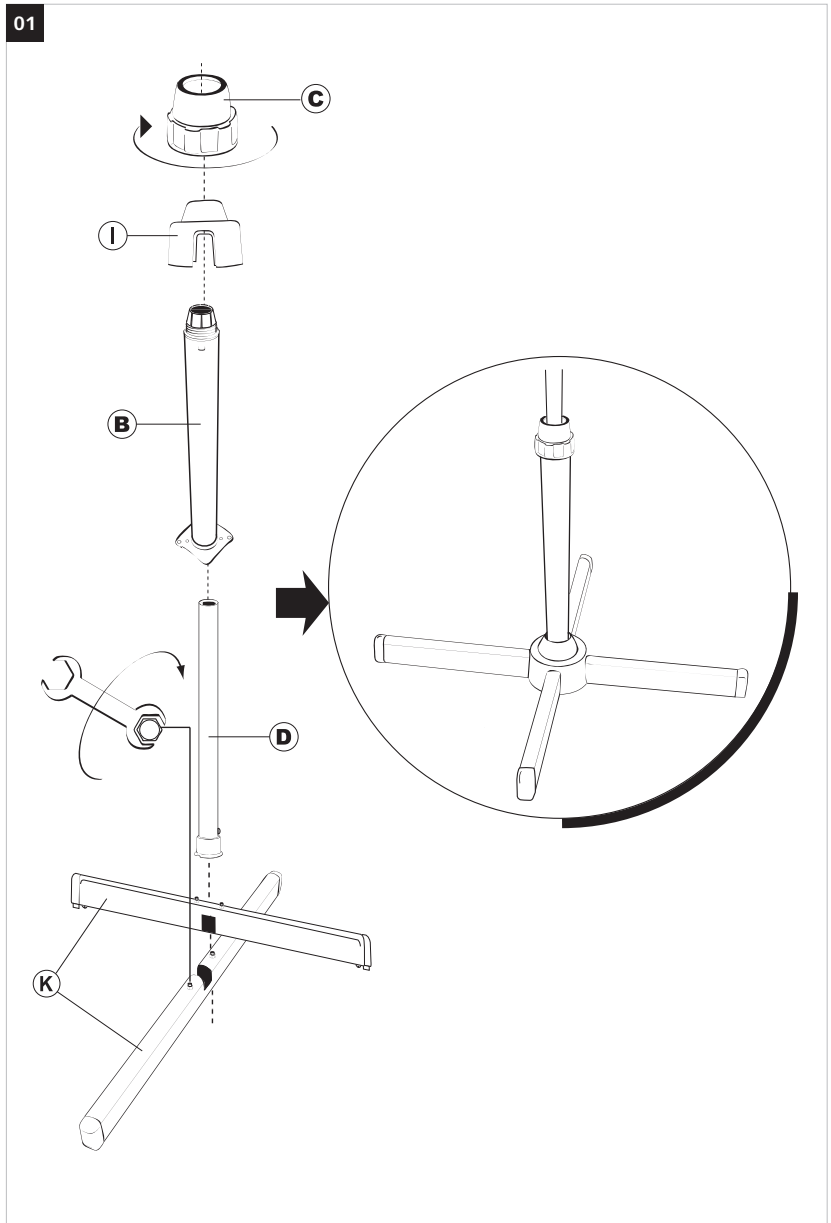



Assemblage de la machine  
Machine assembly

D

02

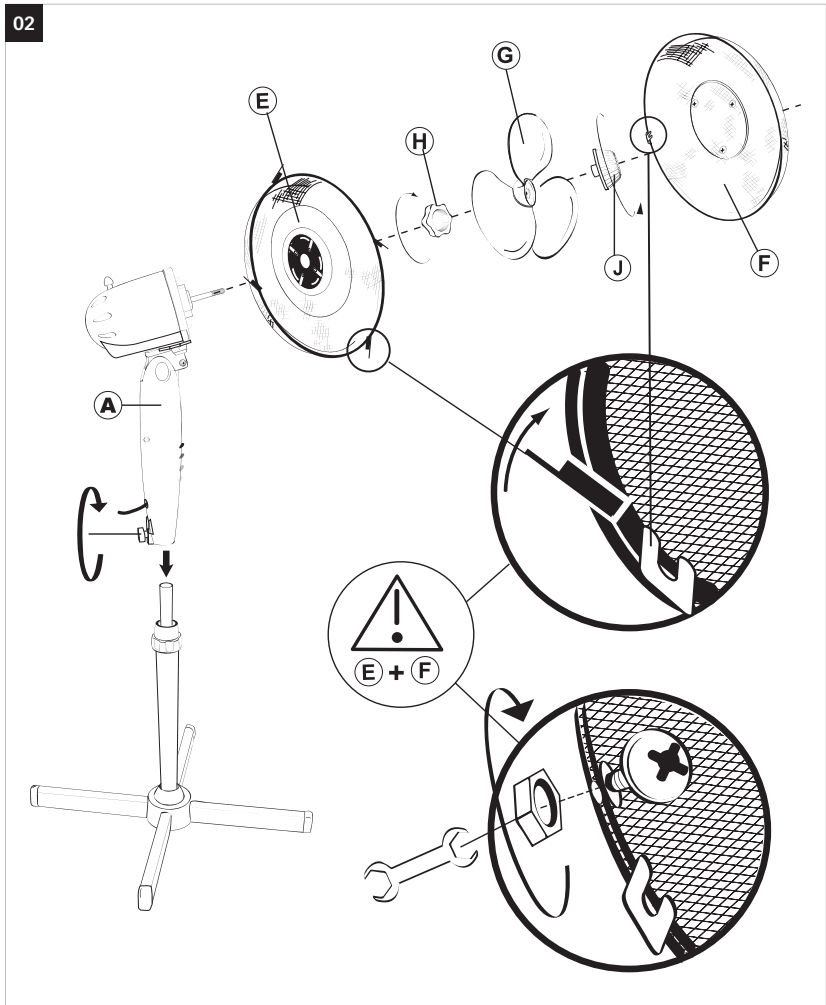



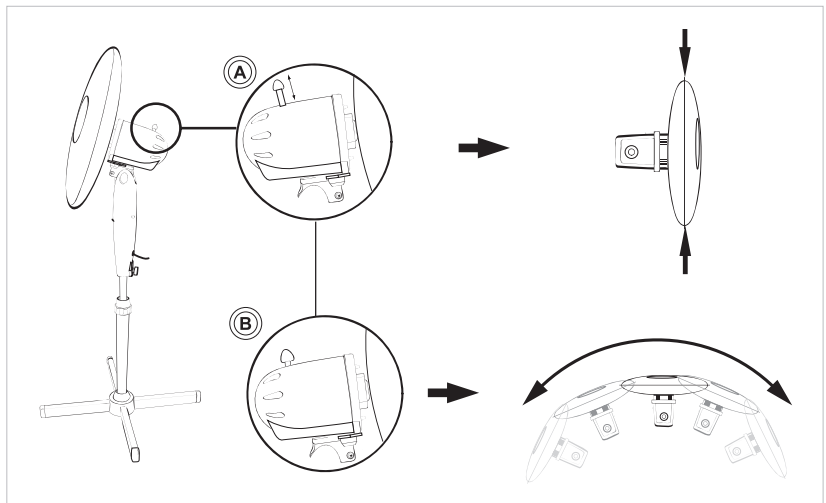
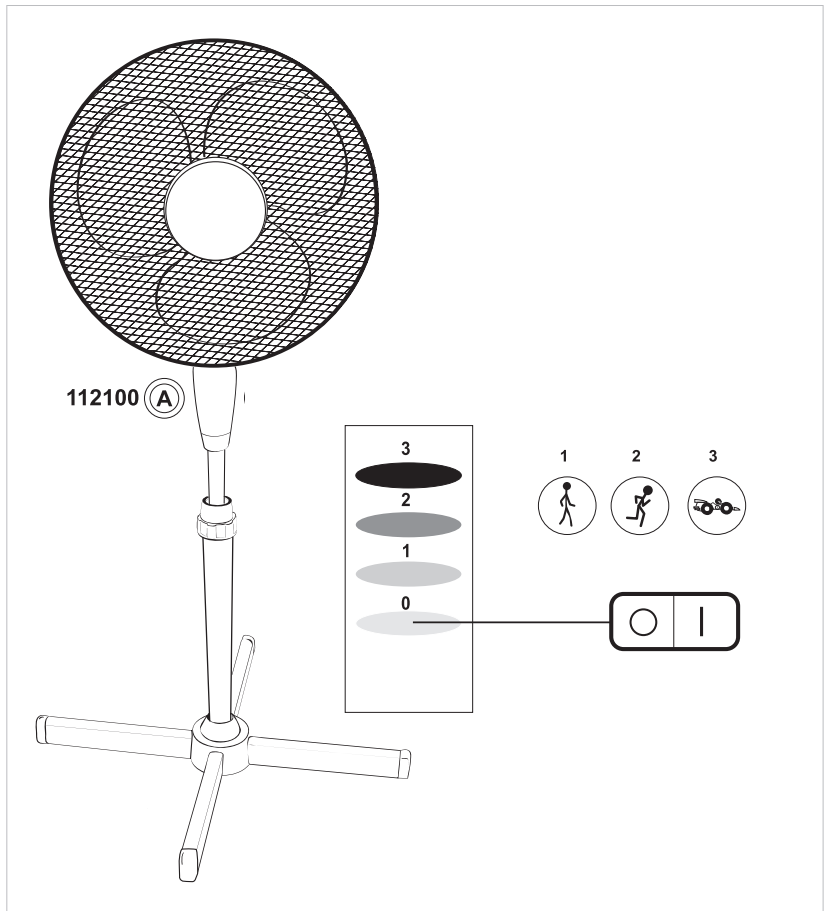

Fonctionnalité de la machine  
Functions of the machine

# E





	<p>Tension et fréquence assignée: Nominal frequency and power: Spannung und Frequenz: Tensión y frecuencia fijada: Tensione e frequenza assegnata: Tensão e frequência fixa: Aangegeven spanning en frequentie: ΟΝΟΜΑΣΤΙΚΗ ΤΑΣΗ ΚΑΙ ΣΥΧΝΟΤΗΤΑ: Napięcie i częstotliwość przydzielona: Jännite ja määrittäty taajuus: Angiven spänning och frekvens: Anført spænding og frekvens: Tensiune și frecvență de lucru:</p>	<p><b>Заданное напряжение и частота:</b> Tahsis gerilimi ve frekansı: Stanovené napětí a frekvence: Stanovené napätie a frekvencia: מתח ותדר מוקצב الغليظة والذبذبة المبرمجة. Névleges feszültség és frekvencia: Napetost in določena frekvenca: <b>Консумирано напрежение и честота :</b> <b>Määratud pinge ja sagedus</b> <b>Nustatyta įtampa ir dažnis</b> <b>Noteiktais spriegums un frekvence.</b> Napon i nazivna frekvencija:</p>	230 V ~ 50 Hz
---	--	--	---------------

	<p>Puissance assignée: Nominal power: Leerlaufdrehzahl: Potencia fijada: Potenza assegnata: Potência assinada: Onbelast toerental: ΟΝΟΜΑΣΤΙΚΗ ΙΣΧΥΣ: Prędkość na biegu jałowym: Teho: Angiven effekt: Anført styrke: Putere de lucru:</p>	<p><b>Заданная мощность:</b> Tahsis edilen güç: Stanovený príkon: Predpísaný výkon: כוח מוקצב. القدرة المبرمجة. Névleges teljesítmény : Določena jakost: <b>Консумирана мощност:</b> <b>Määratud võimsus.</b> <b>Nustatyta galia</b> <b>Noteiktā jauda</b> Nazivna snaga:</p>	50 W
---	---	---	------

	<p>Vitesse à vide: No-load speed: Drehzahl unbelastet: Velocidad vacía: Velocità a vuoto: Velocidade no vácuo: Leerlaufdrehzahl: ΤΑΧΥΤΗΤΑ ΑΔΡΑΝΕΙΑΣ: Prędkość bezciążenia: Tyhjäkäyntinopeus Tomgånghastighet: Hastighed i ubelastet tilstand: Viteza în gol:</p>	<p><b>Скорость вращения на холостом ходу:</b> Boşalma hızı: Rychlost naprázdno: Rýchlosť pri chode naprázdno: מהירות ריק. السرعة على الفارغ. Üres sebesség: Prosti tek: <b>Скорост на празни обороти:</b> <b>Kiirus tühikäigul</b> <b>Tuščio prietaiso greitis</b> <b>Tukšgaitas ātrums</b> Brzina praznog hoda:</p>	950 - 1100 - 1250 min <sup>-1</sup>
--	---	--	-------------------------------------

	<p>Lire les instructions avant usage : Read the instructions before use : Vor Einsatz des Geräts Anweisung lesen : Léase las instrucciones antes de usar : Leggere le istruzioni prima dell'uso : Ler as instruções antes da utilização : Lees voor het gebruik de instructies : ΔΙΑΒΑΣΤΕ ΤΙΣ ΟΔΗΓΙΕΣ ΠΡΙΝ ΑΠΟ ΤΗ ΧΡΗΣΗ : Zapoznać się z instrukcją przed użyciem : Lue ohjeet ennen käyttöä : Läs anvisningarna före användning : læs instruktionerne før brug Înainte de utilizare, citiți instrucțiunile :</p>	<p><b>Внимательно прочитайте следующие инструкции :</b> Kullanmadan talimatları okuyunuz : Pozorně si přečtěte následující pokyny : Pred použitím si precítajte pokyny : זרם חילופי اقرأ التعليمات قبل الاستخدام. használat előtt olvassuk el az utasítást : Pred uporabo preberite ustrezna navodila <b>Прочетете указанията за употреба :</b> <b>Enne kasutamist lugege instruksiooni</b> <b>Prieš naudojimą perskaityti instrukciją</b> <b>izlasīt instrukcijas pirms lietošanas</b> Pročitati upute prije uporabe:</p>	X
---	---	--	---





	Conformité européenne Conforms to EC standards : CE-Konformität : Cumple con las directivas CE : Conforme alle norme CE : Conforme às normas CE : Voldoet aan de EG-normen : ΕΥΡΩΠΑΪΚΗ ΣΥΜΜΟΡΦΩΣΗ Zgodność z normami CE : EU-standardien mukainen : EU-standardien mukainen : Overholder EU standarderne : Conform cu normele europene:	<b>соответствие европейским стандартам:</b> Avrupa uygunluk : evropská shoda : európska dohoda : התאמה לתקנים האירופיים مطابق للمواصفات الأوروبية. evropska ustreznost : európai megfeleléség : <b>Съответствие с европейските норми :</b> Euroopa Liidu vastavusmärk Europinių normų atitikima Atbilstība Eiropas standartiem Euroopska sukladnost	X
--	---	---	---

	Danger : Gefahr : Peligro : Pericolo : Perigo : Gevaar : ΚΙΝΔΥΝΟΣ: Niebezpieczeństwo : Vaara : Fara : Fare : Pericol :	<b>Опасно :</b> Tehlike : Nebezpečí : Nebezpečnost : סכנה. خطر. Veszély : Nevarnost: <b>Опасност :</b> <b>Oht</b> <b>Pavojus</b> Bistamība Opasnost:	X
--	---	--	---

		40 cm
--	--	-------

	Classe d'isolement : 2 Insulation class : 2 Isolierung klasse : 2 Aislamiento clase : 2 Isolamento classe : 2 Isolamento classe : 2 Isolatie Klasse : 2 ΚΑΤΗΓΟΡΙΑ ΜΟΝΩΣΗΣ: 2 Izolacja Klazy : 2 Eristysluokka : 2 Isolering Klass : 2 Isoleringsklasse : 2 Clasă izolatie : 2	<b>Класс изоляции : 2</b> Yalıtım derecesi : 2 Třída izolace : 2 Izolačný systém : 2 סוג בידוד 2. فئة العزل 2. Szigetelési osztály : 2 Razred izolacije : 2 <b>Инструмент Клас : 2</b> <b>Isolatsiooniklass : 2</b> <b>Izolācijas rūšis : 2</b> <b>Izolācijas klase : 2</b> Izolacija klasa: 2	X
--	---	--	---

Exigences d'écoconception - Ecodesign requirements	
Exigences relatives aux informations sur le produit - Product information requirements	
Débit maximum du ventilateur (F) - Maximum fan flow rate (F)	50,58 m³/min
Puissance absorbée du ventilateur (P) - Fan power input (P)	37,1 W
Valeur de service (SV) - Service value (SV)	1,36 (m³/min)/W
Norme de mesure pour la valeur de service - Measurement standard for service value	IEC 60879:2019
Consommation électrique en veille (P <sub>sb</sub> ) - Standby power consumption (P <sub>sb</sub> )	0 W
Niveau de puissance sonore du ventilateur (L <sub>WA</sub> ) - Fan sound power level (L <sub>WA</sub> )	54,2 dB (A)
Vitesse maximale de l'air (C) - Maximum air velocity (C)	2,79 meters/min
Consommation électrique saisonnière (Q) - Seasonal electricity consumption (Q)	11,872 kWh/a





	<p>Soumis à recyclage Subjected to recycling Sujeto a reciclaje Sottoposti a riciclaggio Sujeitos a reciclagem Não deite no lixo : Niet wegwerpen : ΜΗΝ ΤΗΝ ΠΕΤΑΤΕ : Nie wyrzucac : Älä heitä pois luontoon : Batteriet får inte kastas : Bortkast det ikke: Nu le auncati :</p>	<p><b>Не выбрасывайте в мусорный ящик</b> Atmayıniz : Nevyhazujte je do bežného odpadu : Neodhadzovate : אין לזרוק סוללות فلا ترمدها هكذا في القمامة. ne mečíte! Ne odvržite ga/jih vstran : <b>Не го изхвърляйте :</b> Ärge visake seda minema : Nemétykíte : Nemest : Podvrgnuto recikliranju</p>	X
---	--	---	---

	<p>Recyclable, soumis au tri sélectif Recyclable, subject to recycling Recyclingfähige, unterliegen Recycling Reciclables, sujetos a reciclaje Riciclabili, soggetti a riciclaggio Recicláveis, sujeito à reciclagem Recycleerbare, onderworpen aan recycling ΑΝΑΚΥΚΛΩΣΙΜΕΣ ΣΥΣΚΕΥΑΣΙΕΣ ΠΟΥ ΥΠΟΚΕΙΝΤΑΙ ΣΕ ΚΥΚΛΩΣΗ Opakowanie nadaje się do recyklingu podlegają recyklingu Kierrätettävien pakkausten kohteena kierrätys Återvinningsbara förpackningar omfattas återvinning <b>Рециклиращи се опаковки подлежат на рециклиране</b> Genanvendelig underlagt genbrug</p>	<p>Reciclabile sub rezerva reciclare <b>Повторно опаковка подлежи вторичной переработке</b> Gerü dönüſüm Gerü dönüſtürülebilir ambalaj konusu Recyklovateľné podléhajúce recyklácii Recyklovateľné podliehajúce recyklácii החמל והחמל היראה אשונ رېډنډل څا ځال ځيږيږت رېډنډل څا ځال ډل ډاډاډل ډيډل ډيډل Újrahasznosítható csomagolás alá újrahasznosítás Reciklirati predmet recikliranja Pakendite suhtes ringlussevõtu Pärsträdajams iepakojums otrreizējai pārstrādei Perdirbamų taikomos perdirbimo Može se reciklirati, podložno selektivnomu sortiranju</p>	X
---	---	---	---

**FR-Recyclage des déchets:**

Les outils, accessoires et leur emballages doivent suivre une voie de recyclage adaptée. Conformément aux directives Européenne 2012/19/UE et 2006/66/CE, les composants d'un produit doivent être séparés, collectés, recyclés ou éliminés en conformité avec les réglementations environnementales en vigueur. Les appareils, batteries, piles, huiles, emballages devront être déposés dans les systèmes d'élimination des déchets spéciaux tels que déchetteries. Renseignez vous auprès de votre commune pour connaître l'organisme le plus proche à même de traiter ou de collecter ces déchets.

**NL-Waste Recycling:**

Gereedschappen, accessoires en de verpakking moet een recycling traject aangepast volgen. Overeenstemming met de Europese Richtlijnen 2012/19/UE en 2006/66/CE, de onderdelen van een product moet worden gescheiden, verzameld, gerecycleerd of verwijderd in overeenstemming met de milieuvorschriften. Apparaten, batterijen, olie, moet de verpakking worden gedeponneerd in de verwijdering van gevaarlijke afvalstoffen, zoals afvalverwerking systemen. Informeer bij uw gemeente naar de dichtstbijzijnde staat om opnieuw te verwerken of te verzamelen het afval lichaam te vinden.

**EN-Waste recycling:**

The tools, accessories and their packaging must use an appropriate recycling channel. In compliance with European Directives 2012/19/UE and 2006/66/CE, a product's components must be separated, collected, recycled or eliminated in accordance with the environmental regulations in force. The appliance, batteries, oils and packaging must be deposited in the special waste elimination systems such as the waste collection centres. Ask your commune for information on the nearest organisation in a position to reprocess or collect this waste

**ES-Reciclado de los residuos:**

Las herramientas, los accesorios y los envases tienen que seguir la vía de reciclaje adecuada. En virtud de las directivas europeas 2012/19/UE y 2006/66/CE, los componentes de un producto deben separarse, recogerse, reciclarse o eliminarse de acuerdo con las reglamentaciones medioambientales vigentes. Los aparatos, baterías, pilas, aceites, envases deberán llevarse a los centros de eliminación de residuos especiales tales como los ecoparques. Pedir información al municipio par conocer el centro más cercano apto para reciclar o recoger dichos residuos.

**IT-Riciclaggio dei rifiuti:**

Gli apparecchi, i loro accessori ed imballaggi devono essere sottoposti ad un processo di riciclaggio appropriato. In conformità con le direttive europee 2012/19/UE e 2006/66/CE, i componenti di un prodotto devono essere separati, raccolti, riciclati o smaltiti in conformità con le normative ambientali in vigore. Gli apparecchi, le batterie, le pile, gli oli, gli imballaggi dovranno essere conferiti nei sistemi di smaltimento dei rifiuti speciali come le isole ecologiche. Informarsi presso il proprio comune per sapere qual è l'ente più vicino in grado di fare il trattamento o la raccolta differenziata di questi rifiuti

**PT-Reciclagem do lixo:**

As ferramentas, acessórios e suas embalagens devem seguir um canal de reciclagem adaptado. Conformemente às diretivas europeias 2012/19/UE e 2006/66/CE, os componentes de um produto devem ser separados, recolhidos, reciclados ou eliminados de acordo com as regulamentações ambientais em vigor. Os aparelhos, baterias, pilhas, óleos e embalagens deverão ser depositados nos sistemas de eliminação de detritos especiais, tais como unidades de triagem de detritos. Informar-se junto ao seu concelho municipal para conhecer o órgão mais próximo habilitado a evacuar ou recolher estes detritos.





Tennessee

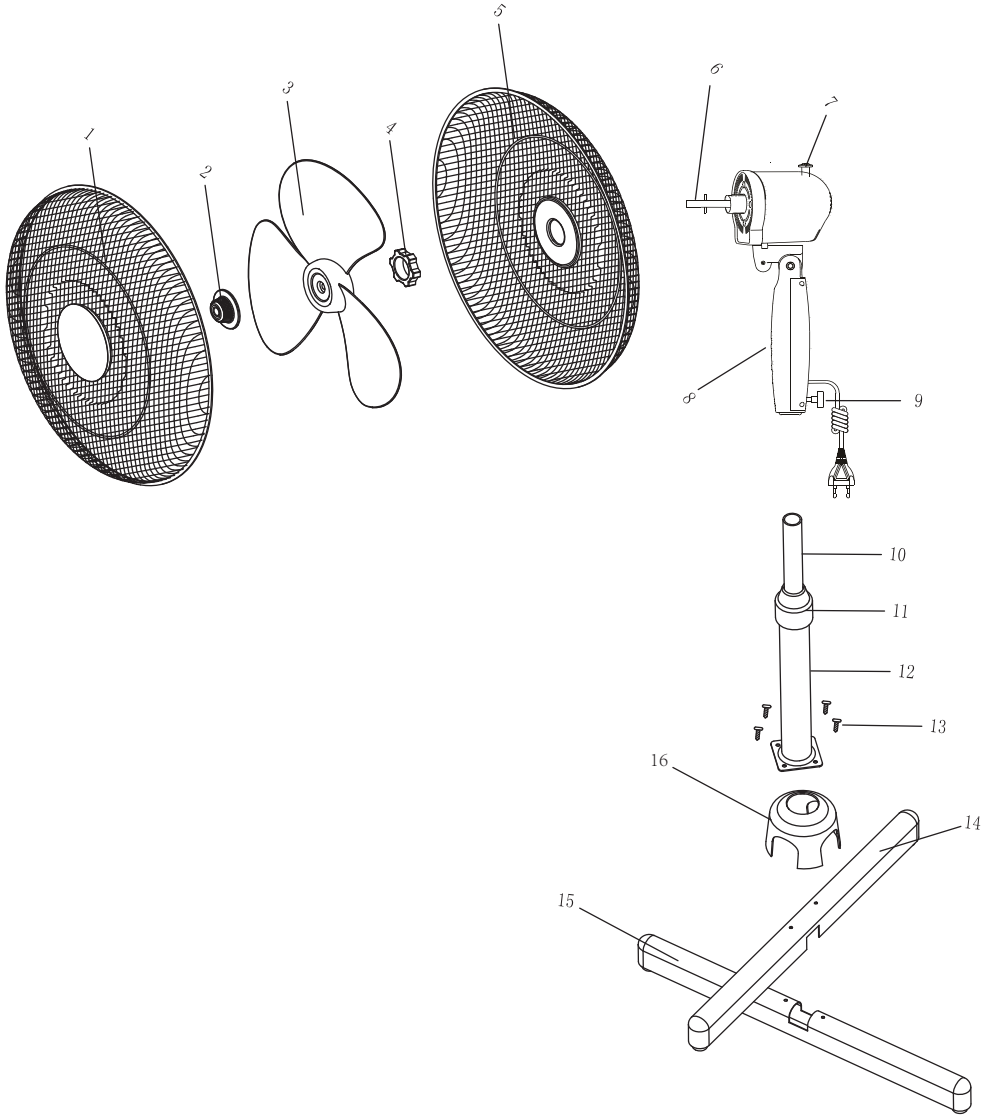



**Plaques signalétiques - naamplaatjes - placas de identificación  
- placas de identificação - targhette - machine labels**

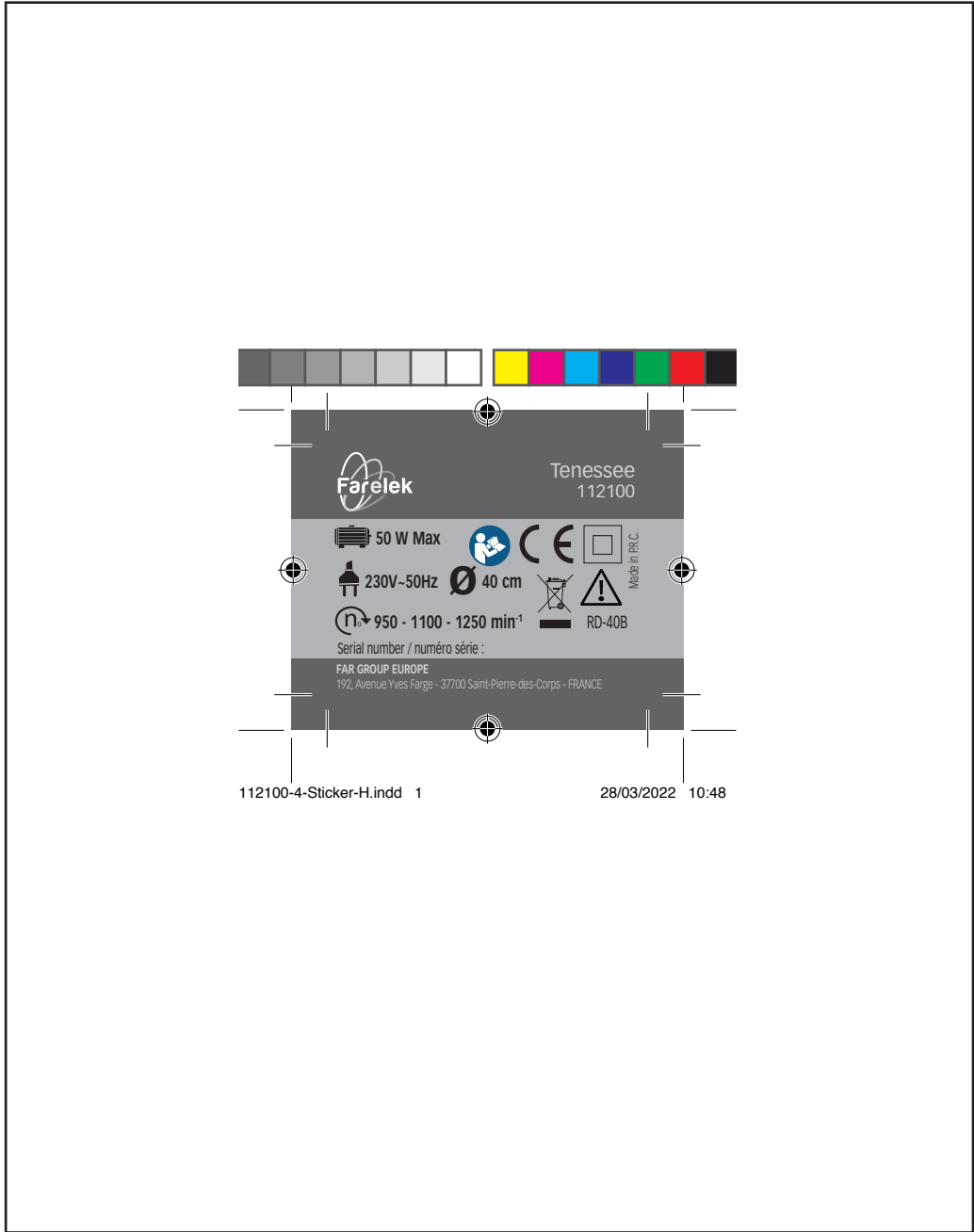

112100-4-Sticker-H.indd 1

28/03/2022 10:48





DECLARATION DE CONFORMITE  
 VERKLARING VAN OVEREENSTEMMING  
 DECLARACION DE CONFORMIDAD  
 DICHIARAZIONE DI CONFORMITA  
 KONFORMITÄSERKLÄRUNG  
 DECLARATION CONFORMITY  
 DECLARAÇÃO DE CONFORMIDADE  
 DEKLARACJA ZGODNOSCI Z NORMAMI  
 OM ÖVERENSSTÄMMELSE  
 VAATIMUSTENMUKAISUUSVAKUUTUS  
 ÖVERENSSTEMMELSESERKLÄRING  
 ΔΗΛΩΣΗ ΣΥΜΜΟΡΦΩΣΗΣ

DECLARAȚIE DE CONFORMITATE  
 VYHLÁSENIE ZHODY  
 Декларация соответствия  
 הודעה תואמת  
 Uygunluk beyanı  
 التصديق بالطابق ة  
 PROHLÁŠENÍ SHODY  
 EGYZŐSÉGI NYILATKOZAT  
 Декларация за съответствие с нормите  
 IZJAVA O SKLADNOSTI  
 DEKLARACIJA  
 ATITIKTIES DEKLARACIJA  
 KINNITUS  
 IZJAVA O SUKLADNOSTI

**Le soussigné,**  
 Ondergetekende,  
 Der Unterzeichner,  
 O abaixo assinado,  
 Undertecknad,  
 Долуподписаният  
 Undertegnede  
 Subseminatul,  
 Я, нижеподписавшийся,  
 Imzalayan,  
 Niže podepsány,  
 Toliau pasirašęs

Personne autorisée à constituer  
 le dossier technique :  
 Christophe HUREL



FAR GROUP EUROPE  
 192, Avenue Yves Farge  
 37700 St. Pierre-des-Corps  
 FRANCE

El suscrito,  
 Il sottoscritto,  
 The undersigned,  
 Níneí podpísany,  
 Allekirjoittanut,  
 Ο ΚΑΤΩΘΙ ΥΠΟΓΡΑΦΜΕΝΟΣ,  
 Nízíse podpísany  
 התחתום מה  
 الحقوق اذناه  
 Alulírott,  
 Podpisani,  
 Apakša parakstijies  
 allakirjutanu  
 Dolje potpisani,

Declara por la presente, que,  
 Dichiare che,  
 Declares that,  
 Oowiadcza niniejszym, że  
 Ilmoitetaan täten että,  
 Δια του παρόντος δηλώνει 'ΟΤΙ,  
 týmto vyhlasuje, že  
 מנהיר בה כן  
 يصرح استنادا على ذلك  
 kijelentem, hogy a készülék Izjavija da,  
 Pareiskia, kad,  
 Ar šo apliecinā, ka,  
 Kinnitab, et  
 Izjavljuje u ovom dokumentu da je

**Déclare par la présente que,**  
 Verklaart hiermede dat,  
 Erklärt hiermit daß,  
 Declara pela presente que,  
 Förklarar härmed att  
 Заявлява с настоящото  
 erklærer hermed, at  
 Declar prin prezenta că,  
 настоящим подтверждаю, что  
 Mecvut belgeyle beyan ediliyor ki,  
 tímto prohlašuje, že,  
 Pareiskia, kad,

Ventilateur / Fan / Ventilator / Ventilador / Ventilatore / Ventilador / Ventilator / Auemisthrax / Wentylator / Flakt /  
 Tuuletin / **вентилятор** / Ventilator / Ventilator / **Потолочный вентилятор** / Tavan ventilatör /  
 Stropní ventilátor / Stropný ventilátor / مؤووة تهوية سقفية / מארר תקרה / Plafonventilátor /  
 Stropni ventilator / Laeventilator / Švytuojantis ventiliatorius / Svarstigais ventilators

**code**

FAELEK / TENESSEE / 112100 / RD-40B

**Est conforme et satisfait aux directives et normes CE,**  
 In overeenstemming is met en Voldoet aan EG richtlijnen,  
 Den folgenden EU-Bestimmungen entspricht,  
 Respeita e está em conformidade com as normas CE,  
 Överensstämmer med och uppfyller EG-standarder,  
 Съответства и отговаря европейските норми  
 Er i overensstemmelse med og overholder EU standarderne  
 Este conform și satisfăce normele CE  
 полностью соответствует и удовлетворяет  
 требованиям стандартов EC  
 CE şartlara uygundur,  
 odpovídá normám ES.  
 Atitinka ir atitinka EB direktyvas ir standartus,

Cumple con la directivas de la CE,  
 E conforme alle direttive CEE,  
 Complies with the EEC directives and standards,  
 Odpowiada normom UE,  
 Täyttää EU-vaatimukset,  
 Συμμορφώνεται και ικανοποιεί τις οδηγίες και τα πρότυπα CE,  
 zodpovedá normám ES.  
 מתאים ועונה לתקני CE  
 بان الهماز يطابق و يلبى معايير مجموعة الدول الأوروبية  
 kiellegiti à CE szabványok előírásait.  
 Je i skladu z in izpolnjuje norme Evropske skupnosti.  
 Atbilst un atbilst EK direktivas un standartus.  
 Vastab ja vastab EU direktiividele ja standarditele,  
 Sukladan i ispunjava direktive i standarde CE,

2011/65/EU 2014/30/EU 2014/35/EU 2015/863/EU 2009/125/EC 2009/125/EC

EN 60335-1 : 2012+A11+A13+A14+A2+A15+A16  
 EN 60335-2-80 : 2003+A1+A2  
 EN 62233 : 2008  
 AfPS GS 2019 : 01

EN IEC 55014-1 : 2021  
 EN IEC 55014-2 : 2021  
 EN IEC 61000-3-2:2019+A1  
 EN 61000-3-3:2013+A1+A2

206/2012 Annex 1  
 EN 50564:2011  
 EN 60704-1:2010+A11:2012  
 EN 60704-2-7:2021  
 IEC 60879:2019

Christophe HUREL,  
 Président Directeur Général  
 08/11/2025  
 Fait à St. Pierre-des-Corps



## GARANTIE - WARRANTY

# 1 AN

## GARANTIE

### FR. GARANTIE

Cet outil est garanti contractuellement contre tout vice de construction et de matière, à compter de la date de vente à l'utilisateur et sur simple présentation du ticket de caisse. La garantie consiste à remplacer les parties défectueuses. Cette garantie n'est pas applicable en cas d'exploitation non conforme aux normes de l'appareil, ni en cas de dommages causés par des interventions non autorisées ou par négligence de la part de l'acheteur. La garantie ne s'applique pas sur les dommages causés par une défaillance de l'outil.

### DE. GARANTIE

Die Garantiezeit für dieses Gerät in bezug auf Konstruktions- und Materialfehler beträgt lt. Vertrag bei Vorlage des Kassabons. Die Garantieleistung besteht im Ersatz schadhafter Teile. Die Garantie erlischt bei einer Einsatz des Geräts, der nicht normentsprechend ist, bei Schäden, die auf unsachgemäße Eingriffe zurückzuführen sind bzw. bei Nachlässigkeit seitens des Käufers. Die Garantie erstreckt sich nicht auf Schäden, die auf Fehlfunktionen des Geräts zurückzuführen sind.

### IT. GARANZIA

Quest' attrezzo è garantito per contratto contro qualsiasi difetto di costruzione e di materia, a partire dalla data di vendita all' utente e su semplice presentazione dello scontrino. La garanzia consiste nel sostituire le parti difettose. Questa garanzia non è applicabile in caso di sfruttamento non conforme alle norme dell' apparecchio, né in caso di danni causati da interventi non autorizzati o da negligenza da parte dell' acquirente. La garanzia non si applica ai danni causati da un' avaria dell' attrezzo.

### EN. GARANTIE

This tool is guaranteed, in writing, against any defect in manufacture of parts from the date of sale, upon simple presentation of the sales slip. The guarantee is limited to the replacement of faulty parts. This guarantee is not applicable in the event of usage which is not conform with the intended usage of the apparatus, nor in the event of damage caused by unauthorised servicing or negligence on behalf of the purchaser. This guarantee does not apply to any damage caused by

the failure of this tool.

### ES. GARANTIA

Esta herramienta se garantiza contractualmente contra todo defecto de construcción y materia, a partir de la fecha de venta a l' usuario y sobre simple presentación del recibo de caja. La garantía consiste en sustituir a las partes defectuosas. Esta garantía no es aplicable en caso de explotación no conforme a las normas del aparato, ni en caso de daños causados por intervenciones no autorizadas o por negligencia por parte del comprador. La garantía no se aplica sobre los daños causados por un fallo del herramienta.

### NL. GARANTIE

Dit gereedschap heeft een garantie tegen constructiefouten en materiaaldefecten, die geldig is vanaf de aankoopdatum door de gebruiker, op vertoning van de kassabon. De garantie betreft de vervanging van de defecte onderdelen. Deze garantie is niet van toepassing indien het apparaat niet volgens de normen gebruikt is, noch in geval van schade veroorzaakt door oneigenlijk gebruik of nalatigheid van de koper. De garantie is niet van toepassing op schade voortvloeiend uit een defect van het gereedschap.

### PT. GARANTIA

Esta ferramenta tem uma garantia contratual contra qualquer defeito de construção e de material, a partir da data de venda ao utilizador e sobre simples apresentação do talão da caixa. A garantia consiste em substituir as partes defeituosas. Esta garantia não é aplicável no caso de exploração não conforme às normas do aparelho, nem em caso de danos causados pelas intervenções não autorizadas ou por negligência da parte do comprador. A garantia não se aplica para os danos causados por uma falha da ferramenta.

### EL. ΕΓΓΥΗΣΗ

ΑΥΤΟ ΤΟ ΕΡΓΑΛΕΙΟ ΕΙΝΑΙ ΣΥΜΒΑΤΙΚΑ ΕΓΓΥΗΜΕΝΟ ΓΙΑ ΟΠΟΙΟΔΗΠΟΤΕ ΚΑΤΑΣΚΕΥΑΣΤΙΚΟ ΚΑΙ ΥΛΙΚΟ ΕΛΑΤΤΩΜΑ, ΑΠΟ ΤΗΝ ΗΜΕΡΟΜΗΝΙΑ ΠΩΛΗΣΗΣ ΣΤΟΝ ΧΡΗΣΤΗ ΚΑΙ ΜΕ ΤΗΝ ΕΠΙΔΕΙΞΗ ΤΗΣ ΑΠΟΔΕΙΞΗΣ ΠΩΛΗΣΗΣ. Η ΕΓΓΥΗΣΗ ΣΥΝΙΣΤΑΤΑΙ ΣΤΗΝ ΑΝΤΙΚΑΤΑΣΤΑΣΗ ΤΩΝ ΕΛΑΤΤΩΜΑΤΙΚΩΝ ΕΞΑΡΤΗΜΑΤΩΝ. ΑΥΤΗ Η ΕΓΓΥΗΣΗ ΔΕΝ ΙΣΧΥΕΙ ΣΕ ΠΕΡΙΠΤΩΣΗ ΛΕΙΤΟΥΡΓΙΑΣ ΠΟΥ ΔΕΝ ΣΥΜΜΟΡΦΩΝΕΤΑΙ ΜΕ ΤΑ ΠΡΟΤΥΠΑ ΤΗΣ ΞΥΣΚΕΥΗΣ, ΟΥΤΕ ΣΕ ΠΕΡΙΠΤΩΣΗ ΖΗΜΙΑΣ ΠΟΥ ΠΡΟΚΑΛΕΙΤΑΙ ΑΠΟ ΜΗ ΕΟΥΣΙΟΔΟΤΗΜΕΝΕΣ ΕΠΕΜΒΑΣΕΙΣ Η ΑΜΕΛΕΙΑ ΕΚ ΜΕΡΟΥΣ ΤΟΥ ΑΓΟΡΑΣΤΗ. Η ΕΓΓΥΗΣΗ ΔΕΝ ΙΣΧΥΕΙ ΓΙΑ ΖΗΜΙΕΣ ΠΟΥ ΠΡΟΚΑΛΟΥΝΤΑΙ ΑΠΟ ΑΣΤΟΧΙΑ ΕΡΓΑΛΕΙΟΥ.

### PL. GWARANCJA

Narz dzie jest obj te gwarancja

na wszelkie wady konstrukcyjne i materiałowe, licząc od daty sprzedaży użytkownikowi i po okazaniu paragonu kasowego. Gwarancja obejmuje wymianę cz. Aci wybrakowanych. Gwarancja nie znajduje zastosowania w przypadku użytkowania niezgodnego z normami urządzenia, ani w przypadku szkód spowodowanych działaniami niedozwolonymi lub zaniedbaniami ze strony nabywcy. Gwarancja nie obejmuje szkód powstałych z powodu upadku urządzenia.

### SV. GARANTI

Detta verktyg har en avtalsenlig garanti mot konstruktions och materialfel, från och med tidpunkten för användarens inköp och genom uppvisning av kassakvittot. Garantin består i att ersätta de bristfälliga delarna. Denna garanti gäller inte om användningen inte motsvarar apparatens standarder, inte heller vid skador som orsakas av ej tillätna ingrepp eller på grund av koparens vårdslöshet. Garantin gäller inte forskador som orsakats av att verktyget fungerat bristfälligt.

### FI. TAKUU

Tämän laitteen takuu on voimassa sopimuksenmukaisesti kattaen kaikki rakenne- ja materiaali- ja lukien ostopäivästä kassakuitia vastaan. Takuu sisältää viallisten osien korvaamisen. Takuu ei korvaa ohjeiden vastaista käyttöä eikä valtuuttamattomien henkilöiden kassittelyä tai ostajan huolimattomuudesta aiheutuneita vahinkoja. Takuu ei vastaa myöskään toimintahäiriöistä aiheutuneita vahinkoja.

### BU. Гаранция

Този инструмент е под договорна гаранция срещу всякакъв дефект в изработката и използваните материали, считано от датата на продажба на потребителя и само срещу представяне на касовата бележка. Гаранционното обслужване се състои в замяна на дефектните части. Настоящата гаранция не е валидна когато апаратът се използва по начин, несъответстващ на стандарта за работа с него, както и в случай на щети, нанесени от неоторизирани лица, или вследствие на проявена небрежност от страна на потребителя. Гаранцията не покрива щети, произтекли вследствие на техническа неизправност на апарата.

### DA. GARANTI

Dette værktøj er dækket af en garantikontrakt for konstruktions- og materialefejl, som gælder fra købsdatoen ved visning af kassabon. Garantien består i at udskifte de defekte dele. Garantien dækker ikke fejl opstået som følge af anvendelse, som ikke overholder

## SERVICE APRÈS VENTE - AFTER SALE SERVICE

FARGROUP EUROPE - 192, Avenue Yves Farge - 37700 St. Pierre-des-Corps - FRANCE

fargroup@fargroup.net

Copyright © - 2026 - Fargroup. All rights reserved.

Plus d'info sur [fartools.com](https://www.fartools.com)

-13-

## GARANTIE - WARRANTY

# 1

## AN

### GARANTIE

standarderne for apparatet, eller skader opstået ved ikke autoriserede indgreb eller sløsethed fra brugerens side. Garantien dækker ikke skader opstået, fordi værktøjet har svigtet.

#### RO. GARANTIE

Acest aparat este garantat din punct de vedere contractual împotriva tuturor viciorilor de construcție și de material, începând de la data vânzării lui către utilizator și la simpla prezentare a bonului de casa. Garanția constă în înlocuirea componentelor defecte. Această garanție nu se aplică în cazul exploatării în alt mod decât cel recomandat de normele aparatului și nici în caz de stricăciuni provocate de intervenții neautorizate sau prin neglijența comparatorului. Garanția nu se aplică asupra pagubelor cauzate de o defectare a aparatului.

#### RU. ГАРАНТИЯ

Данное изделие обладает силой контракта гарантии, покрывающей все возможные дефекты изготовления и материала. Гарантия вступает в силу с даты продажи изделия пользователю, для этого достаточно сохранить и предъявить полученный в кассе чек. Гарантия обязывает изготовителя заменить дефектные части изделия. В случае несоответствия изделия санам использованного демонтажа или ремонта или небрежного обращения действие гарантии прекращается. Гарантия не покрывает ущерба, возникшего в результате сбоев в работе изделия.

#### TU. GARANTI

Bu arac, satis tarihinden itibaren, kullanıcının sağdece vezne alindisini sunmasiya tum uretim ve malzeme hatasina karsi garantilidir. Garanti eksik olan kisimlari degistirmek icindir. Bu garanti aracin sartlarina uygun olmayan isleme durumunda, izin verilmeyen kullanimlardan kaynaklanan, hasarlarda veya alicinin istegi durumunda uygulanmaz. Garanti malzemenin bir eksikliginden meydana gelen bir zararda uygulanmaz.

#### CS. ZÁRUKA

Pro tento nástroj platí smluvní záruka na všechny výrobní a materiálové vady od data prodeje uživateli a na základě předložení pokladního bloku. Záruka spočívá ve výměně vadných částí. Tato záruka neplatí

v případě použití přístroje, které neodpovídá normám, ani v případě škod způsobených nepovolenými zásahy nebo nedbalostí ze strany kupujícího. Záruka se nevztahuje na škody způsobené závadou nástroje.

#### SK. ZÁRUKA

Pre tento nástroj platí zmluvná záruka na všetky výrobné a materiálové chyby od dátumu predaja užívateľovi a na základe predloženia pokladničného bloku. Záruka spočíva vo výmene chybných častí. Táto záruka neplatí v prípade použitia prístroja, ktoré nezodpovedá normám, ani v prípade škod spôsobených nepovolenými zásahmi alebo nedbalosťou zo strany kupujúceho. Záruka sa nevztahuje na škody spôsobené poruchou nástroja.

#### HE. תשובה

ימגב לכל תיוחב תוירחאב הסוכמ הז לכ שמתשמל הריכמה מימ ומוהור רוצייה תללוכ תוירחאה. הפוקה שגו תנצהבו הניא הז תוירחא. סימוכנ סיקלה תפלקה סינקת, דמוע וניאש דויבב שומיש לע להכ יתלב תוברעתהמ האצותכ סרגנש קזנ לא, הנוקה דצמ תונלשר וא תישרומ לשבמ האצותכ סרגנש קזנ הסכמ הניא לכב

#### AR. الضمان

على مجرد توديم نطاقا لشراء يتدغل في تاريخ البيع الى المشتري وبنءا عنيب فني التصدي عوفى الجواند اعترابا ان هذه الاع دة مضمونة شعاقديا من ان الجاهز، ولا فسيح الة تعرضه لتلفات حالة الاستخدام غير المطابق لمعايير لا يكون هذا الضمان قابلا للتطبيق فني علل الضمان فسي سببدال الالءاء الاعطلة لا ينطبق الضمان على الخريد الزاتج عن مخرضة او فسي حالة الالءاء من قبل المشتري باءة عن عمليات تدغل عوي

#### HU. GARANCIA

Erre a szerszámra szerződéses garanciát vállalunk bármilyen gyártási és anyaghibára felmerülése esetére a fogvaszto részere törtent eladás napjától számítva, a penztári blokk egyszere felmütatása elleneben. A garancia a hibás alkatrészek cserejére terjed ki. Ez a garancia nem érvényes, ha a készüleket nem rendelteszszerve használtak, sem illetéktelen beavatkozások, vagy a vásároló hanyagsága okozta károk esetén. A garancia nem fedezi azokat a károkat, melyeket a szerszám hibás működése okozott.

#### SL. GARANCIJA

To orodje je z garancijsko pogodbo zašcitero proti vsem napakam v izdelavi in v sestavnem materialu od datuma prodaje naprej in ta velja ob predložitvi blagajniškega računa. Garancija velja za zamenjavo delov z napako. Ta garancija ne velja za uporabo orodja, ki ni v skladu z normami, predpisanimi za omejeno orodje in za primere okvar, ki nastanejo zaradi nedovoljenih posegov

na orodju ali zaradi malomarnega rokovanja kupca. Garancija ne velja za škodo, ki jo lahko povzroči okvara orodja.

#### ET. GARANTII

See tööriist kuulub lepingu järgi garantiiremonti arvestades alates müumise päevast ja kassatseki alusel kasutatajale koigi konstruktsioonilja materjalvigade puhul. Garantii seisneb defektsete osade välja vahetamises. See garantii ei kehti aparaadi normide ebatavalise eiramise puhul ega ostja poolt keelatud viisil kasutamisesest või hooletussejätmisest tulenevate kahjude korral. Garantii ei kehti seadme defektidest põhjustatud kahjude puhul

#### LV. GARANTĪJA

Šis prietaisys yra uztikrinamas kaip itin geros kokybes, nuo jo pardavimo datos iki jo panaudojimo. Ir jam yra suteikiama garantinis talonas. Garantijos metu galima pakeisti atsiradusius trumplataikius gedimus. Ši garantija netaikoma esant netinkamam naudojimui ar nesilaikant reikiam šio aparato vartojimo instrukcijai, tai pat pačiame virkelyje ji sugadinus. Garantija taip pat netaikoma, prietaisa naudojant ne pagal paskirti ir ji apgadinus

#### LT. GARANTUJA

Šim darbarikam ir ligumà noteikta garantija visiem defektium, kas saistas ar konstrukciju un materialu, sākot ar pardosanas datumu, kad masinu, pardod lietotajam un vienkarši uzradot kases ceku. Garantija iekļau bojoto dalu nomainu. Ši garantija nav deriga, ja aparāts nav lietots saskaņā ar drošības noteikumiem, ne gādijumos ja bojājumi radusies nesānkcionētas lejauksanas gādijuma vai arī pierceja nolaidības del. Garantija nav deriga, ja bojājumi radusies darbarika defekta del

#### HR. JAMSTVO

Ovaj alat ima ugovorno jamstvo u slucaju bilo kakvih nedostataka u konstrukciji i materijalu, od datuma prodaje korisniku uz jednostavno predocenje racuna. Jamstvo se sastoji u zamjeni neispravnih dijelova. Ovo se jamstvo ne primjenjuje u slucaju uporabe i eksploatacije koja nije sukladna standardima uređaja, niti u slucaju stete uzrokovane neovlastenim intervencijama ili nemarom kupca. Jamstvo se ne primjenjuje na štetu uzrokovanu nekim nedostatkom alata.

## SERVICE APRÈS VENTE - AFTER SALE SERVICE

FARGROUP EUROPE - 192, Avenue Yves Farge - 37700 St. Pierre-des-Corps - FRANCE

fargroup@fargroup.net



## FAR GROUP EUROPE

Une société du groupe **SIGMA**

192, Avenue Yves Farge  
37700 St. Pierre-des-Corps  
FRANCE

[www.fartools.com](http://www.fartools.com)  
[fargroup@fargroup.net](mailto:fargroup@fargroup.net)

