



# Voralia

<b>FR</b>	Ventilateur mural (Notice originale)
<b>EN</b>	wall fan (Original manual translation)
<b>DE</b>	Wandventilator (Übersetzung aus dem Original-Anleitung)
<b>ES</b>	ventilador de pared (Traducción del manual de instrucciones originale)
<b>IT</b>	ventilatore da parete (Traduzione dell'avvertenza originale)
<b>PT</b>	ventilador de parede (Tradução do livro de instruções original)
<b>NL</b>	wandventilator (Vertaling van de originele instructies)
<b>EL</b>	επιτοίχος ανεμιστήρας (Μετάφραση από τις πρωτότυπες οδηγίες)
<b>PL</b>	wentylator ścienny (Tłumaczenie z oryginalnej instrukcji)
<b>FI</b>	seinätuuletin (Käännös alkuperäisestä ohjeet)
<b>SV</b>	väggfläkt (Översättning från originalinstruktioner)
<b>BU</b>	стенен вентилатор (Превод на оригиналната инструкция)
<b>DA</b>	vægventilator (Oversættelse fra oprindelige brugsanvisning)
<b>RO</b>	ventilator de perete(instrucțiuni originale)
<b>RU</b>	настенный вентилятор (Перевод с оригинальной инструкции)
<b>TU</b>	duvar tipi vantilatör (Orijinal talimatlar çeviri)
<b>CS</b>	nástěnný ventilátor (Překlad z originálního návodu)
<b>SK</b>	nástěnný ventilátor (Preklad z originálneho návodu)
<b>HE</b>	הודעה מקורית(מאוורר קיר)
<b>AR</b>	مروحة حائط ( دليل الاستخدام الأصلي)
<b>HU</b>	fali ventilátor (Fordítás az eredeti utasítások)
<b>SL</b>	stenski ventilator (Prevod iz izvirnih navodil)
<b>ET</b>	seinaventiilaator (Tõlge originaal juhiseid)
<b>LV</b>	sienas ventilators (Tulkojumā no instrukcijas oriģinālvalodā)
<b>LT</b>	sieninis ventiliatorius (Vertimas iš originalių instrukcijas)
<b>HR</b>	Ventilator na postolju (originalne upute)



© FAR GROUP EUROPE

112330-Manual-A-20251205



farelek.fr



2 min

A

Description et repérage des organes de la machine / Description and location of machine parts / Beschreibung und Kennzeichnung der Maschinenteile / Descripción y localización de los elementos de la máquina / Descrizione e localizzazione degli organi della macchina / Descrição e identificação dos órgãos da máquina / Beschrijving en plaatsbepaling / Laitteen osien kuvaus ja sijainti gen van de onderdelen van de machine / Opis i oznaczenie elementów urzadzenia / Beskrivning och märkning av maskinens delar / описание и местоположение на частите на машината / Beskrivelse og nummerering af maskinens organer / Descrierea și identificarea organelor de masina / описание и маркировка элементов машины / Mäkinenin organlarinin tasvirini ve bulunması / Popis a umístění dílů stroje / Popis a umiestnenie dílov stroja / המכונה והיתור של מכללי המכונה והיתור של מכללי המכונה / توصیف / A gép alkotóelemeinek leírása és beazonosítása / Opis in oznaka sklopov stroja / Masina osade kirjeldus ja eristamine / Mašinas dalu apraksts un uzstādīšana / Mašinos elementu aprašymas ir krypties nustatymas / Opis i identifikacija komponenti stroja

B

Contenu du carton / Contents of box / Inhalt der Verpackung / Contenido del cartón / Contenuto della scatola / Conteúdo da caixa / Inhoud van het karton / Zawartość opakowania / Laatikon sisältö / Innehåll i kartongen / съдържание на кутията / Pakkassens indhold / Continutul cartonului / содержимое коробки / Kartonun içeriği / Montáž stroje / Montáž stroja / תכולה של תיבת הקרטון / תכולה الكارتونة / A doboz tartalma / Vsebina kartona / Karbi sisu / Kastes saturs / Kartono sudetis / Sadržaj kartona

C

Assemblage de la machine / Assembling the machine / Zusammenbau der Maschine / Ensamblaje de la máquina / Assemblaggio della macchina / Montagem da máquina / Assemblage van de machine / Montaż maszyny / Laitteen asennus / Montering av maskinen / събиране на машината / Samling af maskinen / Asamblarea masinii / сборка машины / Mäkinenin montaji / Nastavenie stroje / Nastavenie stroja / הרבבת המכונה / تجميع أجزاء الآلة / A gép összeszerelése / Sestava stroja / Masina kokkupanek / Mašinas montaža / Mašinos surinkimas / Sastavljanje stroja

D

Fonctionnalité de la machine / Functions of the machine / Funktionen der Maschine / Funcionalidad de la máquina / Funzionalità della macchina / Funcionalidade da máquina / Functionaliteit van de machine / Funkcje maszyny / Laitteen käyttö / Maskinens funktion / функциониране на машината / Maskinens virkemåde / Functionarea masinii / функциональность машины / Mäkinenin käyttösilligi / Funkce stroje / Funkcie stroja / כושר תפקוד המכונה / جاذوية الآلة / A gép működése / Funkcionalnost stroja / Masina funktsionaalus / Mašinas funkcionalitate / Mašinos funkcioavimas / Funkcionalnost stroja





Description et repérage des organes de la machine  
Description and location of machine parts

# A



Contenu du carton  
Contents of box

# B

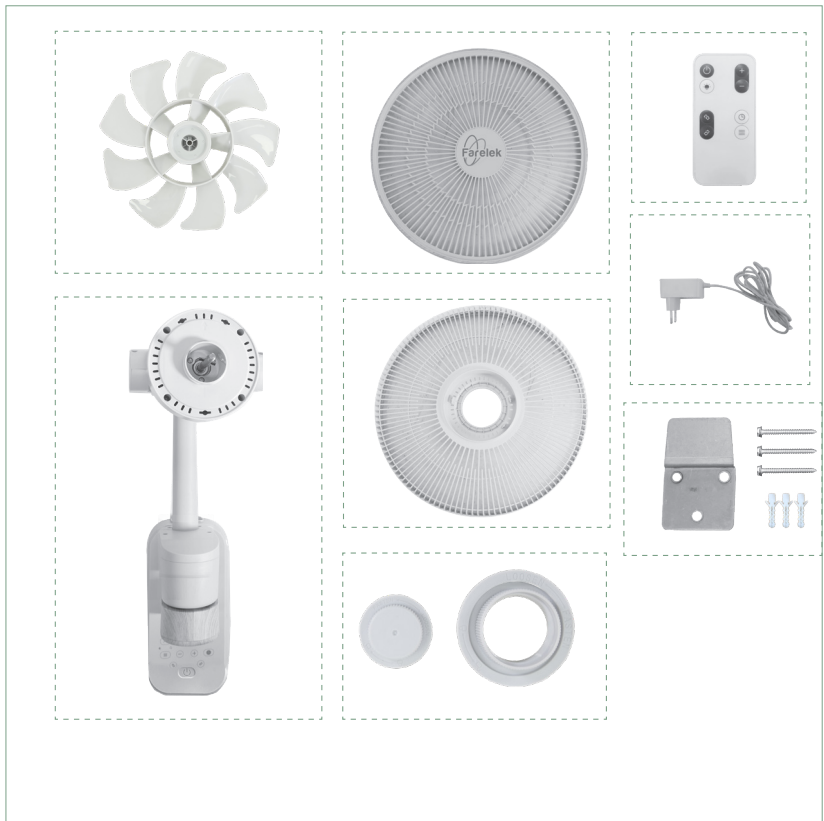



Assemblage de la machine  
Assembling the machine

C

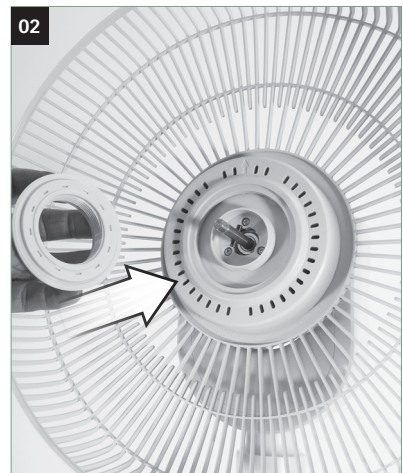
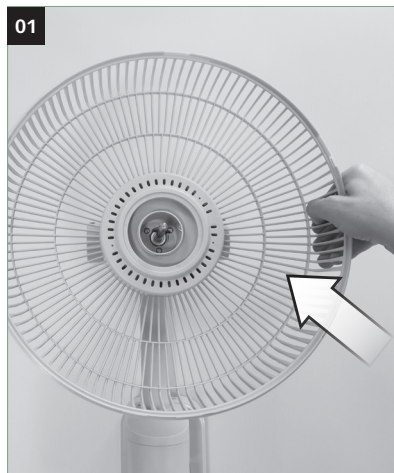
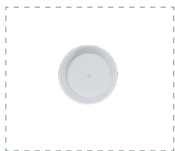
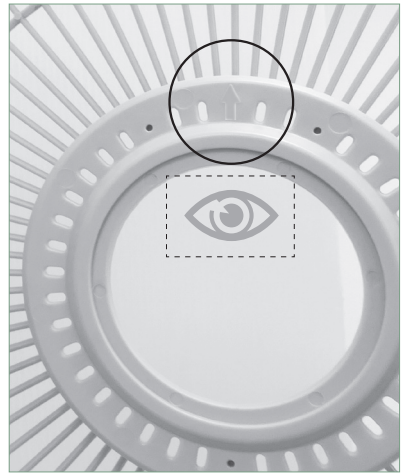



Assemblage de la machine  
Assembling the machine

C

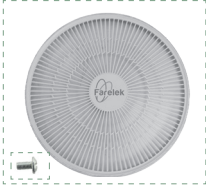

b

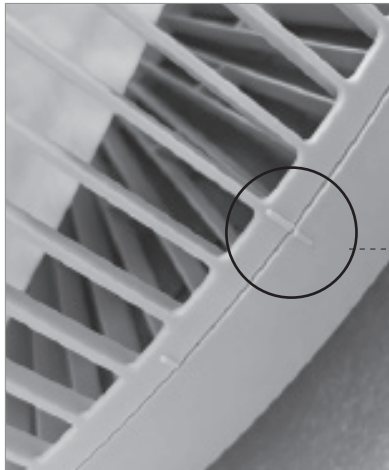



Assemblage de la machine  
Assembling the machine

C



### Adaptez les fixations au matériau qui compose votre mur (bois, brique, plaque de plâtre, béton, etc..)

Adapt the fixings to the material of your wall (wood, brick, plasterboard, concrete, etc.).

Passen Sie die Befestigungen an das Material Ihrer Wand an (Holz, Ziegel, Gipskarton, Beton usw.).

Adapte las fijaciones al material de su pared (madera, ladrillo, cartón yeso, hormigón, etc.).

Adattate i fissaggi al materiale che compone la vostra parete (legno, mattoncartongesso, cemento, ecc.).

Adapte as fixações ao material da sua parede (madeira, tijolo, gesso cartodo, betão, etc.).

Pas de bevestigingen aan het materiaal van uw muur aan (hout, baksteen, gipsplaat, beton, enz.).

Προσαρμόστε τις στερεώσεις στο υλικό από το οποίο είναι κατασκευασμένος ο τοίχος σας (ξύλο, τούβλο, γυψοσανίδα, σκυρόδεμα κ.λπ.).

Dostosuj mocowania do materiału, z którego wykonana jest Twoja ściana (drewno, cegła, płyta gipsowa, beton itp.).

Sovita kiinnikkeet seinäsi materiaaliin (puu, tiili, kipsilevy, betoni jne.).

Anpassa fästena efter materialet i din vägg (trä, tegel, gips, betong osv.).

Адаптирайте крепежите към материала, от който е направена вашата стена (дърво, тухли, гипскартон, бетон и др.).

Tilpas beslagene til materialet, som din væg består af (træ, mursten, gipsplade, beton osv.).

Adaptați fixările la materialul din care este făcut peretele dumneavoastră (lemn, cărămidă, rigips, beton etc.).

Подберите крепления в соответствии с материалом вашей стены (дерево, кирпич, гипскартон, бетон и т.д.).

Duvarınızı oluşturan malzemeye göre bağlantı elemanlarını uyarlayın (ahşap, tuğla, alçıpan, beton vb.).

Prizpůsobte upevnění materiálu, ze kterého je vaše zeď vyrobena (dřevo, cihla, sádrokarton, beton atd.).

Prispôbte upevnenia materiálu, z ktorého je vaša stena vyrobená (drevo, tehla, sadrokartón, betón atď.).

(התאימו את אמצעי הקיבוע לחומר שממנו הקיר שלכם עשוי (עץ, לבנים, גבס, בטון וכו').  
(قم بتكييف أدوات التثبيت حسب مادة الجدار لديك (خشب، طوب، ألواح جيبس، خرسانة، الخ).

Igazítsa a rögzítéseket a fal anyagához (fa, téglá, gipszkarton, beton stb.).

Prilagodite pritrđilne elemente materijalu, iz katerega je vaša stena (les, opeka, mavčna plošča, beton itd.).

Kohandage kinnitused vastavalt seinä materjalile (puu, tellis, kipsplaat, betoon jne).

Pielāgojiet stiprinājumus sienas materiālam (koks, ķieģelis, ģipškartons, betons u.c.).

Pritaikykite tvirtinimus prie sienos medžiagos (medis, plytos, gipskartonis, betonás ir kt.).

Prilagodite učvršćenja materijalu od kojeg je vaš zid napravljen (drvo, cigla, gips ploča, beton itd.).





Assemblage de la machine  
Assembling the machine

C

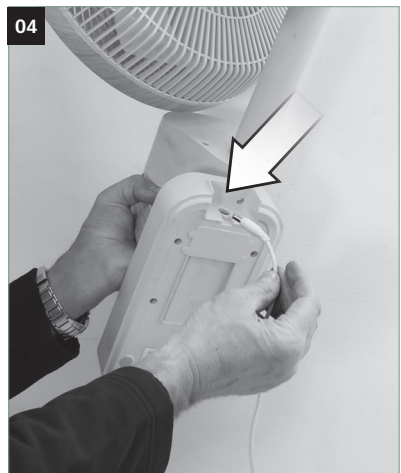
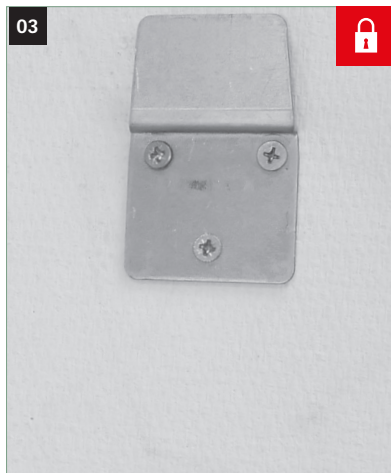
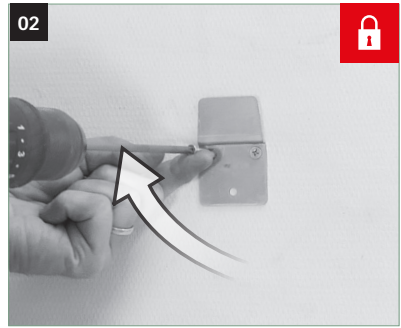
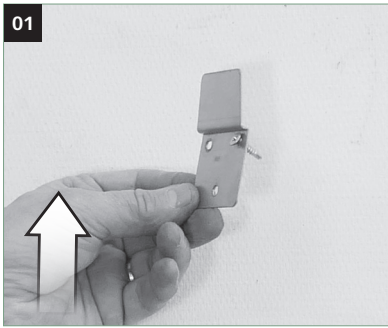



Assemblage de la machine  
Assembling the machine

C

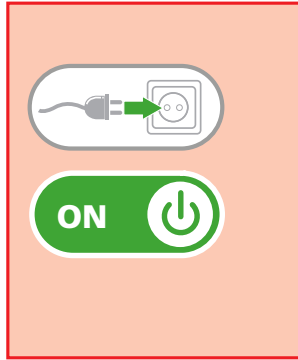

Fonctionnalité de la machine  
Functions of the machine

D

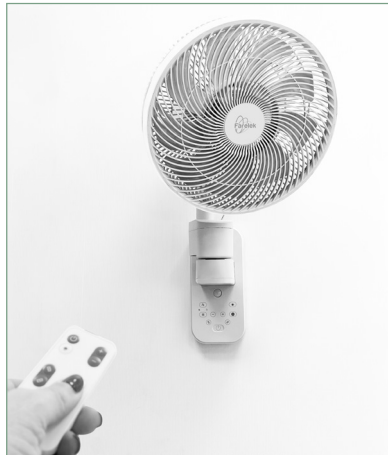
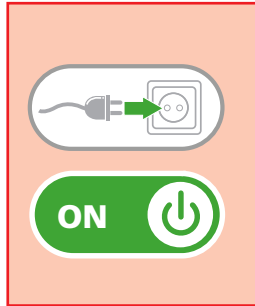



Fonctionnalité de la machine  
Functions of the machine

D

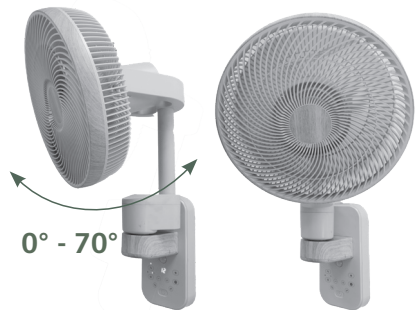
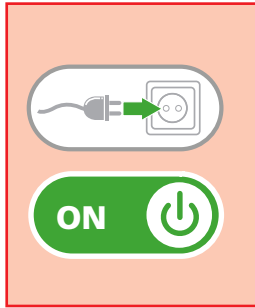



Fonctionnalité de la machine  
Functions of the machine

D

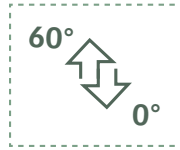

	X1	1H
	X2	2H
	X3	3H
	X4	4H
	X5	5H
	X6	6H
	X7	7H
	X8	8H
	X9	9H





Fonctionnalité de la machine  
Functions of the machine

D

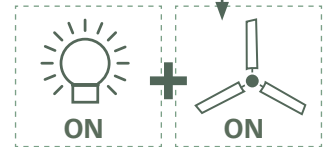
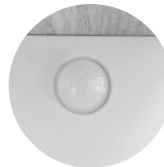
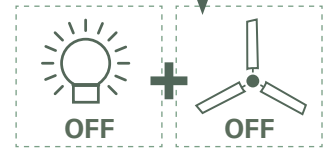
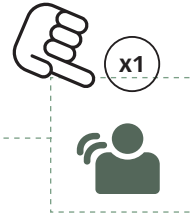



Fonctionnalité de la machine  
Functions of the machine

**D**

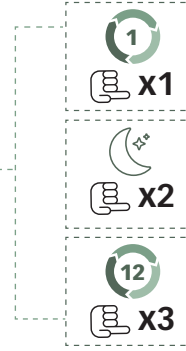
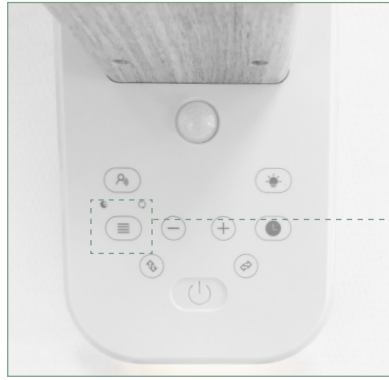



	<p>Tension et fréquence assignée: Nominal frequency and power: Spannung und Frequenz: Tensión y frecuencia fijada: Tensione e frequenza assegnata: Tensão e frequência fixa: Aangegeven spanning en frequentie: <b>Ονομαστική τάση και συχνότητα:</b> Napięcie i częstotliwość przydzielona: Jännite ja määrittäty taajuus: Angiven spänning och frekvens: Anført spænding og frekvens: Tensiune și frecvență de lucru:</p>	<p>Заданное напряжение и частота: Tahsis gerilimi ve frekansı: Stanovené napětí a frekvence: Stanovené napätie a frekvencia: الجهد والتردد المخصص: מתח ותדר שהוקצה: Névleges feszültség és frekvencia: Napetost in določena frekvenca: Консумирано напрежение и честота : Määratud pinge ja sagedus Nustatyta įtampa ir dažnis Noteiktais spriegums un frekvence. Napon i nazivna frekvencija:</p>	230-240 V ~ 50 HZ
--	---	--	-------------------

	<p>Puissance assignée: Nominal power: Leerlaufdrehzahl: Potencia fijada: Potenza assegnata: Potência assinada: Onbelast toerental: <b>Ονομαστική ισχύς:</b> Prędkość na biegu jałowym: Teho: Angiven effekt: Anført styrke: Putere de lucru:</p>	<p>Заданная мощность: Tahsis edilen güç: Stanovený příkon: Predpísaný výkon: القدرة المخصصة: כוח שהוקצה: Névleges teljesítmény : Določena jakost: Консумирана мощност: Määratud võimsus. Nustatyta galia Noteiktā jauda Ocijenjene snage:</p>	12V DC 3.0 A
--	--	---	--------------

	<p>Classe d'isolement : 3 Insulation class : 3 Isolierung klasse : 3 Aislamiento clase :3 Isolamento classe :3 Isolamento classe :3 Isolatie Klasse : 3 <b>Κατηγορία μόνωσης: 3</b> Izolacja Klazy :3 Erístysluokka :3 Isolering Klass :3 Isoleringsklasse 3 Clasă izolatie :3</p>	<p>Класс изоляции 3 : Yalitim derecesi :3 Třída izolace :3 Izolačný systém 3 فئة العزل: 3 דרגת בידוד: 3 Szigetelési osztály :3 Razred izolacije :3 Инструмент Клас:3 Isolatsiooniklass 3 Izolācijas rūšis 3 Izolācijas klase 3 Izolacija klasa: 3</p>	X
--	--	---	---

	<p>Usage intérieur uniquement Indoor Use Only Alleen binnenshuis gebruik Sólo uso en interiores Apenas para uso interno Solo uso interno Χρήση σε εσωτερικούς χώρους Tylko do użytku w pomieszczeniach Vain sisäkäyttöön Endast för inomhusbruk Закрит Използвайте само Kun til indendørs brug Utilizare în interior numai</p>	<p>Только для внутреннего использования Kapalı Use Only Vnitřní použití Vnútorné použitie للاستخدام الداخلي فقط לשימוש פנימי בלבד Csak beltéri használatra Notranja Use Only Kasutamiseks ainult siseruumides Tik naudoti patalpų viduje Lietošanai tikai telpās Nur für Innenräume Samo za unutarnju upotrebu</p>	X
--	--	--	---



	<p>Tension et fréquence assignée: Nominal frequency and power: Spannung und Frequenz: Tensión y frecuencia fijada: Tensione e frequenza assegnata: Tensão e frequência fixa: Aangewezen spanning en frequentie: ΟΝΟΜΑΣΤΙΚΗ ΤΑΣΗ ΚΑΙ ΣΥΧΝΟΤΗΤΑ: Napięcie i częstotliwość przydzielona: Jännite ja määrätty taajuus: Angiven spänning och frekvens: Anført spænding og frekvens: Tensiune și frecvență de lucru:</p>	<p>Заданное напряжение и частота: Tahsis gerilimi ve frekansı: Stanovené napětí a frekvence: Stanovené napätie a frekvencia: الجهد والتردد المخصص: מתח ותדר שהוקצה: Névleges feszültség és frekvencia: Napetost in določena frekvencia: Консумирано напрежение и честота: Määratud pinge ja sagedus Nustatyta įtampa ir dažnis Noteiktais spriegums un frekvence. Napon i nazivna frekvencija:</p>	<p>12V DC 3.0 A</p>
---	--	--	---------------------

	<p>Puissance assignée: Nominal power: Leerlaufdrehzahl: Potencia fijada: Potenza assegnata: Potência assinada: Onbelast toerental: ΟΝΟΜΑΣΤΙΚΗ ΙΣΧΥΣ: Prędkość na biegu jałowym: Teho: Angiven effekt: Anført styrke: Putere de lucru:</p>	<p>Заданная мощность: Tahsis edilen güç: Stanovený příkon: Predpísaný výkon: القدرة المخصصة: כוח שהוקצה: Névleges teljesítmény: Določena jakost: Консумирана мощность: Määratud võimsus. Nustatyta galia Noteiktā jauda Nazivna snaga:</p>	<p>36 W</p>
---	---	--	-------------

	<p>Vitesse à vide: No-load speed: Drehzahl unbelastet: Velocidad vacía: Velocità a vuoto: Velocidade no vácuo: Leerlaufdrehzahl: ΤΑΧΥΤΗΤΑ ΑΔΡΑΝΕΙΑΣ: Prędkość bezciążenia: Tyhjäkäyntinopeus Tomgånghastighet: Hastighed i ubelastet tilstand: Viteza în gol:</p>	<p>Скорость вращения на холостом ходу: Boşalma hızı: Rychlost naprázdno: Rýchlosť pri chode naprázdno: سرعة عدم التحميل: מהירות ללא עומס: Üres sebesség: Prosti tek: Скорост на празни обороти: Kiirus tühikäigul Tušćio prietaiso greitis Tukšgaitas ātrums Brzina praznog hoda:</p>	<p>x 12 - 400-950 tr/min</p>
--	---	---	------------------------------



		30 cm
--	--	-------

	<p>Conformité européenne          Conforms to EC standards :          CE-Konformität :          Cumples con las directivas CE :          Conforme alle norme CE :          Conforme às normas CE :          Voldoet aan de EG-normen :          ΕΥΡΩΠΑΪΚΗ ΣΥΜΜΟΡΦΩΣΗ          Zgodność z normami CE :          EU-standardien mukainen :          EU-standardien mukainen :          Overholder EU standarderne :          Conform cu normele europene:</p>	<p>соответствие европейским стандартам:          Avrupa uygunluk :          evropská shoda :          európska dohoda :          التوافق الأوروبي          קונפורמיות אירופאית          evropska ustreznost :          európai megfeleléség :          Съответствие с европейските норми :          Euroopa Liidu vastavusmärk          Europinių normų atitikima          Atbilstība Eiropas standartiem          Europejska sukladnost</p>	X
--	---	--	---

	<p>Danger :          Danger :          Gefahr :          Peligro :          Pericolo :          Perigo :          Gevaar :          ΚΙΝΔΥΝΟΣ:          Niebezpieczeństwo :          Vaara :          Fara :          Fare :          Pericol :</p>	<p>Опасно :          Tehlike :          Nebezpečí :          Nebezpečnostvo :          خطر          מפגע          Veszély :          Nevarnost:          Опасност :          Oht          Pavojus          Bistamība          Opasnost:</p>	X
--	--	---	---

	<p>Poids :          Weight :          Gewicht :          Peso :          Peso :          الوزن          המשקל          Gewicht :          ΒΑΡΟΣ :          Masa :          Paino :          Vikt :          Vægt :          Greutate :</p>	<p>Бес :          Ağırlik :          Hmotnost :          Hmotnosť :          الوزن          המשקל          Súly :          Teža :          Terlo :          Raskus          Svoris          Svars          Težina</p>	2,7 kg
--	--	---	--------

	<p>Lire les instructions avant usage :          Read the instructions before use :          Vor Einsatz des Geräts Anweisung lesen :          Léase las instrucciones antes de usar :          Leggere le istruzioni prima dell'uso :          Ler as instruções antes da utilização :          Lees voor het gebruik de instructies :          ΔΙΑΒΑΣΤΕ ΤΙΣ ΟΔΗΓΙΕΣ ΠΡΙΝ ΑΠΟ ΤΗ ΧΡΗΣΗ :          Zapoznać się z instrukcją przed użyciem :          Lue ohjeet ennen käyttöä :          Läs anvisningarna före användning :          læs instruktionerne før brug          Înainte de utilizare, cititi instructiunile :</p>	<p><b>Внимательно прочитайте следующие инструкции :</b>          Kullanmadan talimatları okuyunuz :          Pozorně si přečtete následující pokyny :          Pred použitím si prečítajte pokyny :          اقرأ التعليمات قبل الاستخدام          קראו את ההוראות לפני השימוש          használat előtt olvassuk el az utasítást :          Pred uporabo preberite ustrezna navodila          Прочетете указанията за употреба :          Enne kasutamist lugege instruksiooni          Prieš naudojimą perskaityti instrukciją          izlasīt instrukcijas pirms lietošanas          Pročitati upute prije uporabe:</p>	X
--	---	--	---



	<p>Soumis à recyclage Subjected to recycling Sujeto a reciclaje Sottoposti a riciclaggio Sujeitos à reciclagem Não deite no lixo : Niet wegwerpen : ΜΗΝ ΤΗΝ ΤΙΤΕΤΑΕ : Nie wyrzucac : Älä heitä pois luontoon : Batteriet får inte kastas : Bortkast det ikke: Nu le auncati :</p>	<p>Не выбрасывайте в мусорный ящик Atmayiniz : Nevyhazujte je do bežného odpadu : Neodhadzovat : خاضع لإعادة التدوير רמת עוצמה אקוסטית: ne mečíte1 Ne odvržite ga/jih vstran : Не го извървяйте : Ärge visake seda minema : Nemetykete : Nemest : Podvrgnuto recikliranju</p>	X
---	---	---	---

**Recyclage des déchets :**

Les outils, accessoires et leur emballages doivent suivre une voie de recyclage adaptée. Conformément aux directives Européenne 2012/19/UE et 2006/66/CE, les composants d'un produit doivent être séparés, collectés, recyclés ou éliminés en conformité avec les réglementations environnementales en vigueur. Les appareils, batteries, piles, huiles, emballages devront être déposés dans les systèmes d'élimination des déchets spéciaux tels que déchetteries. Renseignez-vous auprès de votre commune pour connaître l'organisme le plus proche à même de retraiter ou de collecter ces déchets.

	<p>Recyclable, soumis au tri sélectif Recyclable, subject to recycling Recyclingfähige, unterliegen Recycling Reciclables, sujetos a reciclaje Riciclabili, soggetti a riciclaggio Recicláveis, sujeito à reciclagem Recycleerbare, onderworpen aan recycling ΑΝΑΚΥΚΛΩΣΙΜΕΣ ΣΥΣΚΕΥΑΣΙΕΣ ΠΟΥ ΥΠΟΚΕΙΝΤΑΙ ΣΕ ΚΥΚΛΩΣΗ Opakowanie nadaje się do recyklingu podlegają recyklingu Kierrätettävien pakkausten kohteena kierrätys Återvinningsbara förpackningar omfattas återvinning Рециклиращи се опаковки подлежат на рециклиране Genanvendelig underlagt genbrug</p>	<p>Reciclabile sub rezerva reciclare Повторно упаковка подлежит вторичной переработке Geri dönüştürme Geri dönüştürülebilir ambalaj konusu Recyklovateľné podliehajúci recyklácii Recyklovateľné podliehajúce recyklácii قابلية لإعادة التدوير، تخضع للفرد الانتقائي ניתן למחזור, בכפוף למיון סלקטיבי Újrahasznosítható csomagolás alá újrahasznosítás Reciklirati predmet recikliranje Pakendite suhtes ringlussevõtu Pärsträdājams iepakojuoms otrreizējai pārstrādei Perdirbamų taikomos perdirbimo Može se reciklirati, podložno selektivnom sortiranju</p>	X
---	--	---	---

IP XO		X
-------	--	---

	<p>Classe d'isolement : 3 Insulation class : 3 Isolierung Klasse : 3 Aislamiento clase :3 Isolamento classe :3 Isolamento classe :3 Isolatie Klasse : 3 Κατηγορία μόνωσης : 3 Izolacja Klazy :3 Eristysluokka :3 Isolering Klass :3 Isoleringsklasse 3 Clasă izolație :3</p>	<p>Класс изоляции 3 : Yalitim derecesi :3 Třída izolace :3 Izolačný systém 3 فئة العزل : 3 דרגת בידוד : 3 Szigetelési osztály :3 Razred izolacije :3 Инструмент Клас :3 Isolatsiooniklass 3 Izoliācijas rūšis 3 Izolācijas klase 3 Izolacija klasa: 3</p>	X
--	--	---	---





Exigences relatives aux informations sur le produit - Product information requirements	
Débit maximum du ventilateur (F) - Maximum fan flow rate (F)	5.72 m <sup>3</sup> /min
Puissance absorbée du ventilateur (P) - Fan power input (P)	26.9 W
Valeur de service (SV) - Service value (SV)	0.212 (m <sup>3</sup> /min)/W
Consommation électrique en veille (P <sub>SB</sub> ) - Stanby power consumption (P <sub>SB</sub> )	0
Niveau de puissance sonore du ventilateur (L <sub>WA</sub> ) - Fan sound power level (L <sub>WA</sub> )	53.466 dB (A)
Vitesse maximale de l'air (C) - Maximum air velocity (C)	3,921 mètres/min
Consommation électrique saisonnière (Q) - Seasonal electricity consumption (Q)	8.81 kWh/a

Norme de mesure pour la valeur du service Measurement standard for service value	EN IEC 60879: 2019+A1:2025 EN IEC 60704-1:2021 EN IEC 60704-2-7: 2020
---	---

 <b>L<sub>WA</sub></b>	Niveau de puissance acoustique : Acoustic power level : Schalleistungspegel : Nivel de potencia acústica : Livello di potenza acustica: Nivel de potência acústica: Niveau akoestisch vermogen : ΕΠΙΠΕΔΟ ΙΣΧΥΟΣ ΉΧΟΥ: Poziom mocy akustycznej : Käytä suojalaseja : Ljudstyrkenivå : Lydstyrke : Nivel putere acustică :	уровень мощности звука : Akustik basınç seviyesi : Hladina zvukového výkonu: Hladina zvukového výkonu: مستوى قوة الصوت רמת עוצמה אקוסטית a hangnyomás szintje : Nivo akustične jakosti : Равнище на вибрации : Helivõimsuse nivoo Triukšmo lygis Akustiskās jaudas līmenis Razina zvučne snage:	53.466 dB (A)



NOVOPOLSKO

# VORALIA

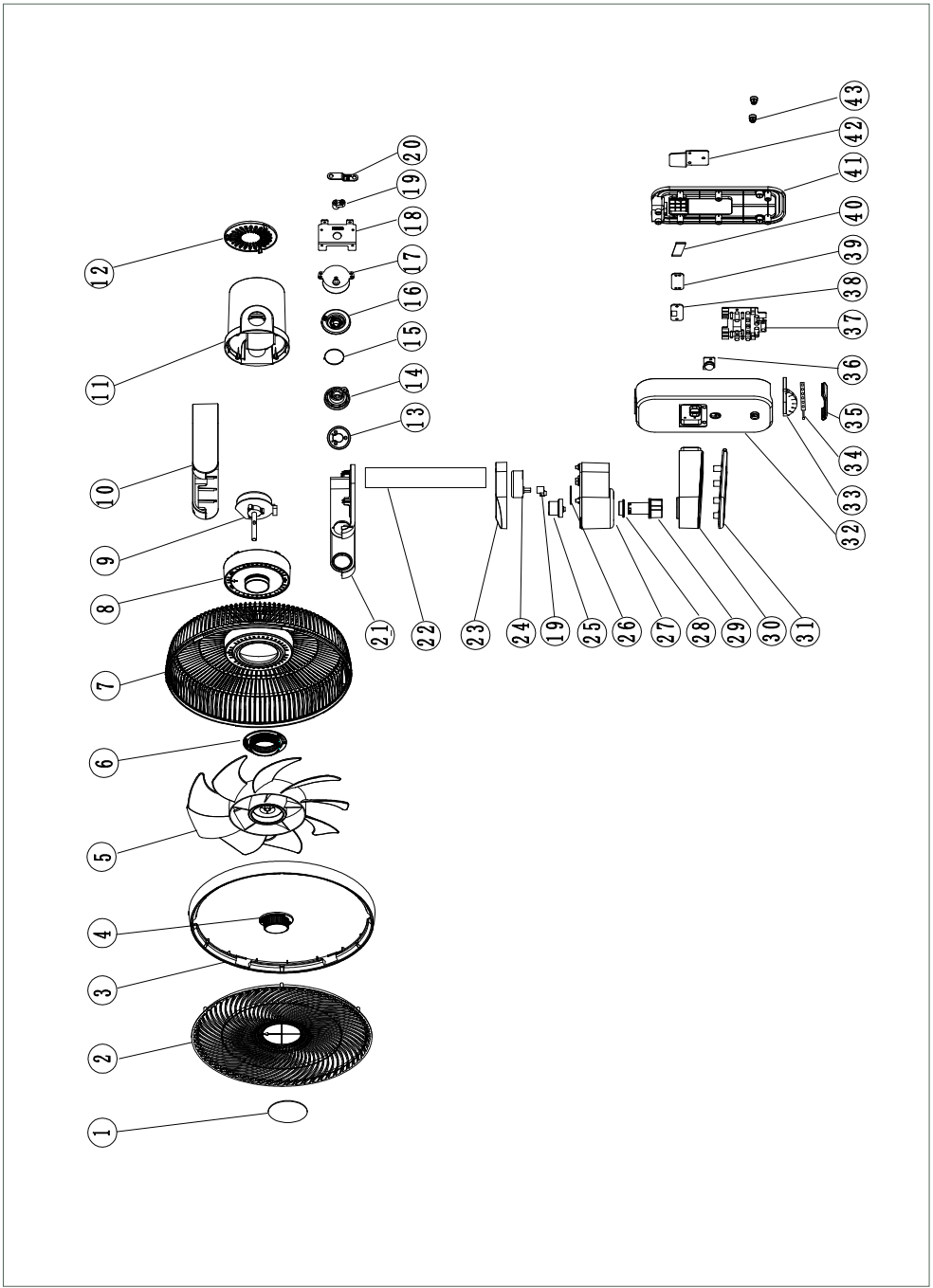

E I L F O C C E E T T O C C A

2 2

E E E E E E E





DECLARATION DE CONFORMITE  
 VERKLARING VAN OVEREENSTEMMING  
 DECLARACION DE CONFORMIDAD  
 DICHIARAZIONE DI CONFORMITA  
 KONFORMITÄSERKLÄRUNG  
 DECLARATION CONFORMITY  
 DECLARAÇÃO DE CONFORMIDADE  
 DEKLARACJA ZGODNOSCI Z NORMAMI  
 OM ÖVERENSSTÄMMELSE  
 VAATIMUSTENMUKAISUUSVAKUUTUS  
 ÖVERENSSTEMMELSESERKLÄRING  
 ΔΗΛΩΣΗ ΣΥΜΜΟΡΦΩΣΗΣ

DECLARAȚIE DE CONFORMITATE  
 VYHLÁSENIE ZHODY  
 Декларация соответствия  
 Uygunluk beyanı  
 إعلان المطابقة  
 הצהרת תאימות  
 PROHLÁŠENÍ SHODY  
 EGYZESÉGI NYILATKOZAT  
 Декларация за съответствие с нормите  
 IZJAVA O SKLADNOSTI  
 DEKLARACIJA  
 ATITIKTIES DEKLARACIJA  
 KINNITUS  
 IZJAVA O SUKLADNOSTI

**Le soussigné,**  
 Ondergetekende,  
 Der Unterzeichner,  
 O abaixo assinado,  
 Undertecknad,  
 Долуподписаният  
 Undertegnede  
 Subseminatul,  
 Я, нижеподписавшийся,  
 Imzalayan,  
 Niže podepsany,  
 Toliau pasirašęs

Personne autorisée à constituer  
 le dossier technique :  
 Christophe HUREL



FAR GROUP EUROPE  
 192, Avenue Yves Farge  
 37700 St. Pierre-des-Corps  
 FRANCE

El suscrito,  
 Il sottoscritto,  
 The undersigned,  
 Níneį podpisany,  
 Allékirjoittanut,  
 Ο ΚΑΤΩΘΙ ΥΠΟΓΡΑΦΜΕΝΟΣ,  
 Nizšie podpisany

Alulírott,  
 Podpisani,  
 Apakšá párkstijies  
 allakirjutanu  
 Dolje potpisani,

Declara por la presente, que,  
 Dichiare che,  
 Declares that,  
 Oowiadzca niniejszym, że  
 Ilmoitetaan täten että,  
 ΔΙΑ ΤΟΥ ΠΑΡΟΝΤΟΣ ΔΗΛΩΝΕΙ ΟΤΙ,  
 týmto vyhlasuje, že  
 أعلن بموجب هذا أنه  
 אני מצהיר בזאת כי  
 kijelentem, hogy a készülék Izjavlja da,  
 Pareškia, kad,  
 Ar šo apliecinā, ka,  
 Kinnitab, et  
 izjavljuje u ovom dokumentu da je

**Déclare par la présente que,**  
 Verklaart hiermede dat,  
 Erklärt hiermit daß,  
 Declara pela presente que,  
 Förklarar härmed att  
 Заявляя с настоящюото  
 erklærer hermed, at  
 Declar prin prezenta că,  
 настоящим подтверждаю, что  
 Mevcut belgeyle beyan ediliyor ki,  
 timto prohlašuje, že,  
 Pareškia, kad,

Ventilateur / Fan / Ventilator / Ventilador / Ventilatore / Ventilador / Ventilator / Auemisthrax / Wentylator / Flakt /  
 Tuuletin / **вентилятор** / Ventilator / Ventilator / **Потолочный вентилятор** / Tavan ventilatör /  
 Stropní ventilátor / Stropný ventilátor / مَرُوحة تَهْوِيَة سَفَافِيَة / מאור תקרה / Plafonventilátor /  
 Stropni ventilator / Laeventilator / Švytuojantis ventiliatorius / Svarstigais ventilators

**code**

FARELEK / 112330 /VORALIA / FS-09A

**Est conforme et satisfait aux directives et normes CE,**  
 In overeenstemming is met en Voldoet aan EG richtlijnen,  
 Den følgende EU-Bestimmungen entspricht,  
 Respeita e está em conformidade com as normas CE,  
 Överensstämmer med och uppfyller EG-standarder,  
 Съответства и отговаря европейските норми  
 Er i overensstemmelse med og overholder EU standarderne  
 Este conform și satisfacă normele CE  
 полностью соответствует и удовлетворяет  
 требованиям стандартов EC  
 CE şartlara uygundur,  
 odpovídá normám ES.  
 Atitinka ir atitinka EB direktyvas ir standartus,

Cumple con la directivas de la CE,  
 E conforme alle direttive CEE,  
 Complies with the EEC directives and standards,  
 Odpowiada normom UE,  
 Täyttää EU-vaatimukset,  
 Συμμορφώνεται και ικανοποιεί τις οδηγίες και τα πρότυπα CE,  
 zopovedá normám ES.  
 يتوافق ويلبي توجيهات ومعايير  
 CE.  
 עומד בהנחיות ובתקנים של  
 kielégíti a CE szabványok előírásait.  
 Je v skladu z in izpolnjuje norme Evropske skupnosti.  
 Atbilst un atbilst EK direktīvas un standartus.  
 Vastab ja vastab EU direktīvidele ja standartidele,  
 Sukladan i ispunjava direktive i standarde CE,

2011/65/EU 2015/863/EU 2014/30/EU 2014/35/EU  
 2009/125/EU 2023/826/EU 206/2012/EU

EN 60335-1:2012+A11+A13+A14+A15+A16  
 EN IEC 60335-2-80:2024+A11  
 EN 62233:2008  
 EN 61000-3-3:2013+A1+A2  
 EN IEC 55014-1:2021  
 EN IEC 55014-2:2021  
 EN IEC 61000-3-2:2019+A1+A2

EN IEC 61558-1: 2019  
 EN 61558-2-16:2009+A1  
 EN 61558-1:2005+A1  
 EK1 527-12 Rev. 2  
 EK1 557-13

EN IEC 60879:2019+A1:2025  
 EN IEC 60704-1:2021  
 EN IEC 60704-2-7:2020  
 EN 50564: 2011

Christophe HUREL,  
 Président Directeur Général  
 09/12/2025  
 Fait à St. Pierre-des-Corps



## GARANTIE - WARRANTY

# 2 ANS

GARANTIE

### FR. GARANTIE

Cet outil est garanti contractuellement contre tout vice de construction et de matière, à compter de la date de vente à l'utilisateur et sur simple présentation du ticket de caisse. La garantie consiste à remplacer les parties défectueuses. Cette garantie n'est pas applicable en cas d'exploitation non conforme aux normes de l'appareil, ni en cas de dommages causés par des interventions non autorisées ou par négligence de la part de l'acheteur. La garantie ne s'applique pas sur les dommages causés par une défaillance de l'outil.

### DE. GARANTIE

Die Garantiezeit für dieses Gerät in bezug auf Konstruktions- und Materialfehler beträgt 1. Vertrag bei Vorlage des Kassensbons. Die Garantieleistung besteht im Ersatz schadhafter Teile. Die Garantie erlischt bei einem Einsatz des Geräts, der nicht normentsprechend ist, bei Schäden, die auf unsachgemäße Eingriffe zurückzuführen sind bzw. bei Nachlässigkeit seitens des Käufers. Die Garantie erstreckt sich nicht auf Schäden, die auf Fehlfunktionen des Geräts zurückzuführen sind.

### IT. GARANZIA

Quest' attrezzo è garantito per contratto contro qualsiasi difetto di costruzione e di materia, a partire dalla data di vendita all' utente e su semplice presentazione dello scontrino. La garanzia consiste nel sostituire le parti difettose. Questa garanzia non è applicabile in caso di sfruttamento non conforme alle norme dell' apparecchio, né in caso di danni causati da interventi non autorizzati o da negligenza da parte dell' acquirente. La garanzia non si applica ai danni causati da un' avaria dell' attrezzo.

### EN. GARANTEE

This tool is guaranteed, in writing, against any defect in manufacture or parts from the date of sale, upon simple presentation of the sales slip. The guarantee is limited to the replacement of faulty parts. This guarantee is not applicable in the event of usage which is not conform with the intended usage of the apparatus, nor in the event of damage caused by unauthorised servicing or negligence on behalf of the purchaser. This guarantee does not apply to any damage caused by

the failure of this tool.

### ES. GARANTIA

Esta herramienta se garantiza contractualmente contra todo defecto de construcción y materia, a partir de la fecha de venta a l' usuario y sobre simple presentación del recibo de caja. La garantía consiste en sustituir a las partes defectuosas. Esta garantía no es aplicable en caso de explotación no conforme a las normas del aparato, ni en caso de daños causados por intervenciones no autorizadas o por negligencia por parte del comprador. La garantía no se aplica sobre los daños causados por un fallo del herramienta.

### NL. GARANTIE

Dit gereedschap heeft een garantie tegen constructiefouten en materiaaldefecten, die geldig is vanaf de aankoopdatum door de gebruiker, op vertoning van de kassabon. De garantie betreft de vervanging van de defecte onderdelen. Deze garantie is niet van toepassing indien het apparaat niet volgens de normen gebruikt is, noch in geval van schade veroorzaakt door oneigenlijk gebruik of nalatigheid van de koper. De garantie is niet van toepassing op schade voortvloeiend uit een defect van het gereedschap.

### PT. GARANTIA

Esta ferramenta tem uma garantia contratual contra qualquer defeito de construção e de material, a partir da data de venda ao utilizador e sobre simples apresentação do talão da caixa. A garantia consiste em substituir as partes defeituosas. Esta garantia não é aplicável no caso de exploração não conforme as normas do aparelho, nem em caso de danos causados pelas intervenções não autorizadas ou por negligência da parte do comprador. A garantia não se aplica para os danos causados por uma falha da ferramenta.

### EL. ΕΓΓΥΗΣΗ

ΑΥΤΟ ΤΟ ΕΡΓΑΛΕΙΟ ΕΙΝΑΙ ΣΥΜΒΑΤΙΚΑ ΕΓΓΥΗΜΕΝΟ ΓΙΑ ΟΠΟΙΟΔΗΠΟΤΕ ΚΑΤΑΣΚΕΥΑΣΤΙΚΟ ΚΑΙ ΥΛΙΚΟ ΕΛΑΤΤΩΜΑ, ΑΠΟ ΤΗΝ ΗΜΕΡΟΜΗΝΙΑ ΠΩΛΗΣΗΣ ΣΤΟΝ ΧΡΗΣΗΤΗ ΚΑΙ ΜΕ ΤΗΝ ΕΠΙΔΕΙΞΗ ΤΗΣ ΑΠΟΔΕΙΞΗΣ ΠΩΛΗΣΗΣ. Η ΕΓΓΥΗΣΗ ΣΥΝΙΣΤΑΤΑΙ ΣΤΗΝ ΑΝΤΙΚΑΤΑΣΤΑΣΗ ΤΩΝ ΕΛΑΤΤΩΜΑΤΙΚΩΝ ΕΞΑΡΤΗΜΑΤΩΝ. ΑΥΤΗ Η ΕΓΓΥΗΣΗ ΔΕΝ ΙΣΧΥΕΙ ΣΕ ΠΕΡΙΠΤΩΣΗ ΛΕΙΤΟΥΡΓΙΑΣ ΠΟΥ ΔΕΝ ΣΥΜΜΟΡΦΩΝΕΤΑΙ ΜΕ ΤΑ ΠΡΟΤΥΠΑ ΤΗΣ ΣΥΣΚΕΥΗΣ, ΟΥΤΕ ΣΕ ΠΕΡΙΠΤΩΣΗ ΖΗΜΙΑΣ ΠΟΥ ΠΡΟΚΑΛΕΙΤΑΙ ΑΠΟ ΜΗ ΕΞΟΥΣΙΟΔΟΤΗΜΕΝΕΣ ΕΠΕΜΒΑΣΕΙΣ Ή ΑΜΕΛΕΙΑ ΕΚ ΜΕΡΟΥΣ ΤΟΥ ΑΓΟΡΑΣΤΗ. Η ΕΓΓΥΗΣΗ ΔΕΝ ΙΣΧΥΕΙ ΓΙΑ ΖΗΜΙΕΣ ΠΟΥ ΠΡΟΚΑΛΟΥΝΤΑΙ ΑΠΟ ΑΣΤΟΧΙΑ ΕΡΓΑΛΕΙΟΥ.

### PL. GWARANCJA

Narz dzie jest objte gwaranc-

ją na wszelkie wady konstrukcyjne i materiałowe, licząc od daty sprzedaży u użytkownika i po okazaniu paragonu kasowego. Gwarancja obejmuje wymianę części wybrakowanych. Gwarancja nie znajduje zastosowania w przypadku u użytkownika niezgodnego z normami urządzenia, ani w przypadku szkód spowodowanych działaniami niedozwolonymi lub zaniedbaniami ze strony nabywcy. Gwarancja nie obejmuje szkód powstałych z powodu upadku urządzenia.

### SV. GARANTI

Detta verktyg har en avtalsenlig garanti mot konstruktions och materialfel, från och med tidpunkten för användarens inköp och genom uppvisning av kassakvittot. Garantin består i att ersätta de bristfälliga delarna. Denna garanti gäller inte om användningen inte motsvarar apparatens standarder, inte heller vid skador som orsakas av ej tillåtna ingrepp eller på grund av köparens vårdslöshet. Garantin gäller inte för skador som orsakats av att verktyget fungerat bristfälligt.

### FI. TAKUU

Tämän laitteen takuu on voimassa sopimuksen mukaisesti katkaen kaikki rakennet ja materiaali- ja lukien ostopäivästä kassakuittia vastaan. Takuu sisältää viallisten osien korvaamisen. Takuu ei korvaa ohjeidenvastaista käyttöä eikä valtuuttamattomien henkilöiden käsittelystä tai ostajan huolimattomuudesta aiheutuneita vahinkoja. Takuu ei vastaa myöskään toimintavaikeuksista aiheutuneita vahinkoja.

### BU. Гаранция

Този инструмент е под договорна гаранция срещу всякакъв дефект в изработката и използваните материали, считано от датата на продажба на потребителя и само срещу представяне на касовата бележка. Гаранционното обслужване се състои в замяна на дефектните части. Настоящата гаранция не е валидна когато апаратът се използва по начин, несъответстващ на стандарта за работа с него, както и в случай на щети, нанесени от неоторизирани лица, или вследствие на проявена небрежност от страна на потребителя.

Гаранцията не покрива щети, произтекли вследствие на техническа неизправност на апарата.

### DA. GARANTI

Dette værktøj er dækket af en garantikontrakt for konstruktions- og materialefejl, som gælder fra købsdatoen ved visning af kassebonen. Garantien består i at udskifte de defekte dele. Garantien dækker ikke fejl opstået som følge af anvendelse, som ikke overholder standarderne for apparatet, eller

## SERVICE APRÈS VENTE - AFTER SALE SERVICE

FARGROUP EUROPE - 192, Avenue Yves Farge - 37700 St. Pierre-des-Corps - FRANCE

fargroup@fargroup.net

## GARANTIE - WARRANTY

# 2

## ANS

GARANTIE

skader opstået ved ikke autoriserede indgreb eller sløsethed fra brugerens side. Garantien dækker ikke skader opstået, fordi værktøjet har svigtet.

### RO. GARANTIE

Acest aparat este garantat din punct de vedere contractual împotriva tuturor viciilor de construcție și de material, începând de la data vânzării lui către utilizator și la simpla prezentare a bonului de casă. Garanția constă în înlocuirea componentelor defecte. Aceasta garanție nu se aplică în cazul exploatarii în alt mod decât cel recomandat de normele aparatului și nici în caz de stricăciuni provocate de intervenții neautorizate sau prin neglijența cumpărătorului. Garanția nu se aplică asupra pagbelor cauzate de o defectare a aparatului.

### RU. ГАРАНТИЯ

Данное изделие обладает имеющей силу контракта гарантией, покрывающей все возможные дефекты изготовления и материала. Гарантия вступает в силу с даты продажи изделия пользователю, для этого достаточно сохранить и предъявить полученный в кассе чек. Гарантия обязывает изготовителя заменить дефектные части изделия. В случае не соответствующего нормам использования изделия, несанкционированного демонтажа или ремонта или небрежного обращения действие гарантии прекращается. Гарантия не покрывает ущерба, возникшего в результате своей в работе изделия.

### TU. GARANTI

Bu arac, satis tarihinden itibaren, kullanıcının sâdece vezne alınırsini sunmasıyla tüm üretim ve malzeme hatasına karşı garantilidir. Garanti eksik olan kisimlari degistirilmek icindir. Bu garanti aracin sartlarina uygun olmayan isleme durumunda, izin verilmeden kullanimlardan kaynaklanan hasarlarda veya alincin istegi durumunda uygulanmaz. Garanti malzemenin bir eksikliginden meydana gelen bir zararda uygulanmaz.

### CS. ZÁRUKA

Pro tento nástroj platí smluvní záruka na všechny výrobny a materiálve vady od data prodeje uživateli a na základě předložení pokladního bloku. Záruka spočívá ve výměně vadných částí. Tato záruka neplatí v případě použití přístroje, které neodpovídá normám, ani v případě

škod způsobených nepovolenými zásahy nebo nedbalostí ze strany kupujícího. Záruka se nevztahuje na škody způsobené závadou nástroje.

### SK. ZÁRUKA

Pre tento nástroj platí zmluvná záruka na všetky výrobne a materiálve chyby od dátumu predaja užívateľovi a na základe predloženia pokladničného bloku. Záruka spočíva vo výmene chybných častí. Táto záruka neplatí v prípade použitia prístroja, ktore nezodpovedá normám, ani v prípade škod spôsobených nepovolenými zásahmi alebo nedbalosťou zo strany kupujúceho. Záruka sa nevzťahuje na škody spôsobené poruchou nástroja.

### HE. SZERZÁRKA

ימגפ לכל תיוח תוירחא הסוכמ הז ליכ שמתשמל הריכמה סוימ רמוחהו וריגיה תללוכ תוירחאה. הפוקה שוג תנעהבו הניא ו תוירחא. סימגפ סיקלה תפלחה הניא ו תוירחא. סימגפ דמוע וניאש דויבב שוימיש לל הלח יתלב תוברעתהמ האצותכ סרגנש קזנ לל וא תוירחאה. הנוקה דצמ תונלשר וא תישרומ לשבמ האצותכ סרגנש קזנ הסכמ הניא לכב

### AR. الضمان

على مجرد تقديم بطاقة الشراء يتعلم عن تاريخ البيع الى المشتري وبين ان يبيع في التصدي عوفى المواعيد اعتبارا من هذه الة مدة مضمونة تعاقدية من أي الجهاز، ولا في حالة تعرضه لالتلافات حالة الاستخدام غير المطابق لمعايير التي يكون هذا الضمان قابلا للتطبيق في حالة ان فاني سبببدال الاجزاء الة اعطاة لا يطبق الضمان على الخردرات الناتج عن مخرضة او في حالة الة العمل من قبل المشتري باتجاه عن عمليات تعديل غير

### HU. GARANCIA

Erre a szerszámra szerződéses garanciát vállalunk bármilyen évtartási és anyaghiba felmerülése esetére, a fogvaszto reszere tortent eladás napjától számítva, a penztári blokk egyszerű felmutatása ellenében. A garancia a hibás alkatrészek cserejére terjed ki. Ez a garancia nem érvényes, ha a készületeket nem rendeltetésszerűen használták, sem illetékelen beavatkozások, vagy a vásárló hanyagsága okozta károk eseten. A garancia nem fedezi azokat a károkat, melyeket a szerszám hibás működése okozott.

### SL. GARANCIJA

To orodje je z garancijsko pogodbo zašciteno proti vsem napakam v izdelavi in v sestavnem materialu od datuma prodaje naprej in ta velja ob predložitvi blagajniškega računa. Garancija velja za zamenjavo delov z napako. Ta garancija ne velja za uporabo orodja, ki ni v skladu z normami, predpisanimi za omenjeno orodje in za primere okvar, ki nastanejo zaradi nedovoljenih posegov na orodju ali zaradi malomarnega rokovanja kupca. Garancija ne velja za škodo, ki jo lahko povzroci

okvara orodja.

### ET. GARANTII

See toorist kuulub lepingu järgi garantiiremonti arvestades alates müumise päevast ja kassatseki alusel kasutatajale kõigi konstruktsiooni- ja materjalivigade puhul. Garantii seisneb defektsete osade välja vahetamises. See garantii ei kehti aparaadi normide ebatavalise eiramise puhul ega ostja poolt keelatud viisil kasutamistest või hooletusetahtmistest tulenevate kahjude korral. Garantii ei kehti seadme defektidest põhjustatud kahjude puhul.

### LV. GARANTĪJA

Šis prietaisys yra uztiķināmas kaip itin geros kokybes, nuo jo pardavimo datos iki jo panaudojimo, ir jam yra suteikiama garantinis talonas. Garantijos metu galima pakeisti atsiradusius trūpialaikius gedimus. Si garantija netaikoma esant netinkamam naudojimui ar nesilaikant reikiam šio aparato vartojimo instrukcijų, tai pat paciam perkelui j sugadinus. Garantija taip pat netaikoma, prietaisa naudojant ne pagal paskirtį ir j apgadinus.

### LT. GARANTIJA

Šim darbarikam ir liguma noteikta garantija visiem defektiem, kas saistās ar konstrukciju un materiālu, sākot ar pardosanas datumu, kad mašīnu pardot lietotājam un vienkāšji uzradot kases ceku. Garantija iekļauj bojāto daļu nomaiņu. Ši garantija nav derīga, ja aparāts nav lietots saskaņā ar drošības noteikumiem, ne gādijumos ja bojājumi radusies nesankcionētas ielauksanas gādijuma vai arī pierceja holaidības del. Garantija nav derīga, ja bojājumi radusies darbarika defekta del.

### HR. JAMSTVO

Ovaj alat ima ugovorno jamstvo u slučaju bilo kakvih nedostataka u konstrukciji i materijalu, od datuma prodaje korisniku uz jednostavno predocenje racuna. Jamstvo se sastoji u zamjeni neispravnih dijelova. Ovo se jamstvo ne primjenjuje u slučaju uporabe i eksploatacije koja nije sukladna standardima uređaja, niti u slučaju štete uzrokovane neovlastenim intervencijama ili nemarom kupca.

Jamstvo se ne primjenjuje na štetu uzrokovanu nekim nedostatkom alata.

## SERVICE APRÈS VENTE - AFTER SALE SERVICE

FARGROUP EUROPE - 192, Avenue Yves Farge - 37700 St. Pierre-des-Corps - FRANCE

fargroup@fargroup.net



0123456789A B C D E F G H I J K L M N O P Q R S T U V W X Y Z

0123456789A B C D E F G H I J K L M N O P Q R S T U V W X Y Z

0123456789A B C D E F G H I J K L M N O P Q R S T U V W X Y Z

0123456789A B C D E F G H I J K L M N O P Q R S T U V W X Y Z

## FAR GROUP EUROPE

Une société du groupe **SIGMA**

192, Avenue Yves Farge  
37700 St. Pierre-des-Corps  
FRANCE

[farelek.fr](http://farelek.fr)

