

LISTO



Aide à la réparation / Aftersales solutions
Lave-linge / Washing machine
LF714L1B

8010325

CONTENU / TABLE OF CONTENT

- Mises en garde / Warning
- Outils nécessaires / Necessary Tools
- Vue éclatée / Exploded view
- Liste des pièces détachées / Spare parts list
- Codes erreurs / Errors codes
- Schémas électriques et électroniques / Electric and electronic diagrams
- Autoréparabilité / Self-repair : Consignes de sécurité pour le démontage de votre appareil / Safety instructions related to the maintenance of your product
- Rappel des consignes élémentaires d'entretien / Reminder of basic maintenance instructions

Cette notice a pour but de vous donner les informations principales vous permettant d'entretenir ou de dépanner votre lave-linge.

Des consignes de sécurité complètent les consignes d'installation et d'utilisation que vous retrouvez dans la notice d'utilisation de votre appareil.

AVERTISSEMENT

Pour votre sécurité, nous recommandons de confier les réparations et l'entretien exclusivement à des professionnels qualifiés tout au long de la vie de votre appareil. Pendant la période de garantie de votre appareil, confiez l'entretien ou les réparations à un personnel qualifié et autorisé.

Tout démontage ou dommage au produit causé par une tentative de réparation du produit par une personne non agréée pourra engendrer une exclusion de garantie si le lien entre la tentative d'auto réparation et le dysfonctionnement rencontré est établi.

En cas de réparation du produit effectuée par une personne non agréée, ou par l'utilisateur lui-même, Sourcing & Création ne peut être tenu responsable de tout dommage causé au produit, ou de toute blessure, dans la mesure où ils sont liés à une maladresse de l'utilisateur ou au non-respect par ce dernier des consignes de réparation du produit.

L'utilisateur peut procéder à une réparation par lui-même sur les pièces de rechange suivantes : joints, filtres, charnières de porte, accessoires en plastique.

Les réparations et tentatives de réparation par l'utilisateur pour les pièces ne figurant pas dans cette liste et/ou ne suivant pas les instructions de sécurité, pourraient donner lieu à des problèmes de sécurité non imputables à Sourcing & Création.

En outre, pour garantir la sécurité du produit et de l'utilisateur, la réparation doit être effectuée en suivant les instructions de sécurité mentionnées ci-après.

Il est donc fortement recommandé aux utilisateurs de s'abstenir de tenter d'effectuer des réparations ne figurant pas sur la liste des pièces de rechange mentionnées, en s'adressant dans ce cas à des réparateurs professionnels autorisés ou agréés. Au contraire, de telles tentatives de la part des utilisateurs peuvent causer des problèmes de sécurité et endommager le produit, provoquer un incendie, des fuites d'eau, une électrocution et des blessures corporelles graves.

The purpose of this manual is to give you the main information allowing you to maintain or troubleshoot your washing machine.

Safety instructions supplement the installation and use instructions that you find in the manual for your device.

WARNING

For your safety, we recommend that repairs and maintenance be carried out exclusively by qualified professionals throughout the life of your device. During the warranty period of your device, entrust maintenance or repairs to qualified and authorized personnel.

Any disassembly or damage to the product caused by an attempt to repair the product by an unauthorized person may result in an exclusion of warranty if the link between the attempted self-repair and the malfunction encountered is established.

In the event of repair of the product carried out by an unauthorized person, or by the user himself, Sourcing & Création cannot be held responsible for any damage caused to the product, or any injury, insofar as they are related to clumsiness on the part of the user or non-compliance by the latter with the product repair instructions









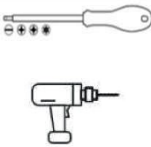

The user can repair the following spare parts himself: seals, filters, door hinges, plastic accessories.

Repairs and attempted repairs by the user for parts not appearing in this list and / or not following the safety instructions, could give rise to safety problems not attributable to Sourcing & Création.

In addition, to ensure the safety of the product and the user, the repair must be carried out following the safety instructions mentioned below.





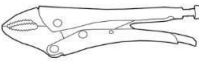

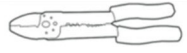

It is therefore strongly recommended that users refrain from attempting to carry out repairs that are not on the list of spare parts mentioned, in this case contacting authorized or approved professional repairers. On the contrary, such attempts by users may cause safety problems and damage the product, cause fire, electric shock, and serious bodily injury. professional repairers. On the contrary, such attempts by users may cause safety problems and damage the product, cause fire, water leakage, electric shock, and serious bodily injury.

OUTILS / TOOLS

Type d'outil / Tool type	Illustration / Drawing	Spécificité / Specificity (Normes et autres/Standards and others)	Commentaire / Remark
Paire de gants anti-coupures Pair of cut resistant gloves		EN388 – EN420 ISO 13997	Indispensable / essential
Lunettes de protection Protective glasses		EN166	Indispensable / essential
Visseuse électrique* ou jeu de tournevis à tête fendue, à empreinte cruciforme, à empreinte pozidriv, à empreinte torx Cordless Screwdriver or screwdriver Set Slotted, Phillips Head, Pozidriv Drive, Torx Drive		ISO 2380, ISO 8764, ISO 10664 Mention VDE**	Indispensable / essential
Jeu de clés pour vis à 6 pans creux et torx Set of keys for hexagon socket and torx screws		ISO 2936	Indispensable / essential
Jeu de clés mixtes de 8 à 19 (8-10-11-12-13-14-16-17-18-19) Set of combination wrenches 8 to 19 (8-10-11-12-13-14-16-17-18-19)		ISO 7738	Indispensable / essential
Jeu de clés à pipe de 8 à 19 (8-9-10-11-12-13-14-15-16-17-18-19) Pipe wrench set from 8 to 19 (8-10-11-12-13-14-16-17-18-19)		ISO 2236	Indispensable / essential
Pince universelle Universal pliers		ISO 5746 Mention VDE**	Indispensable / essential
Pince à bec demi-rond Half-round nose pliers		ISO 5745 Mention VDE**	Indispensable / essential
Pince coupante diagonale Diagonal cutters		ISO 5749 Mention VDE**	Indispensable / essential
Pince multiprise Multigrip pliers		ISO 8976 Mention VDE**	Indispensable / essential
Pince étau Vise grips		Longueur/ Length : 250 MM	Optionnel / Optional

*Attention ! Utilisez un couple de serrage adapté pour ne pas endommager l'appareil.

*Caution! Use the correct torque to avoid damage to the unit.

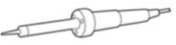
Pince universelle pour dénuder et sertir Universal stripping pliers and crimp			Optionnel / Optional
Levier Pry tool		Plastique glissant, rigide et dur Slippery, rigid and hard plastic	Optionnel / Optional
Pincette Tweezers		Antistatique Antistatic	Optionnel / Optional
Marteau Hammer		Tête métallique Metal head	Optionnel / Optional
Couteau universel (cutter) Universal knife (cutter)		Avec lame rétractable With retractable blade	Optionnel / Optional
Loupe Magnifying glass			Optionnel / Optional
Pistolet à colle Hot glue gun		Utilisation : pour fixer les câblages, en remplacement des adhésifs défectueux Use: glue point to fix cables, replacing defective adhesives	Optionnel / Optional
Multimètre Multimeter		Fonctions mesurées : Courant / tension AC-DC, ampérage, résistance, continuité Measured functions : AC-DC current, voltage, amperage, resistance, continuity	Optionnel / Optional
Fer à souder + panne à souder fine Soldering iron + fine soldering tip		Température $\approx 390^{\circ}\text{C}$ Puissance 20/40W Temperature $\approx 390^{\circ}\text{C}$ Power 20/40W	Optionnel / Optional

** La mention VDE indique que l'outil est totalement isolé et qu'il a été soumis au test diélectrique à 10.000 V. Utilisation : travaux sous tension allant jusqu'à 1000V.

** The VDE mention indicates that the tool is fully insulated and that it has been subjected to the dielectric test at 10.000V . Use : work under voltage up to 1000V.

Conseils / Advice

Il est recommandé de travailler dans un espace dégagé et sécurisé, de poser l'appareil sur une surface plane et propre.

It is recommended to work in an open and safe space, to place the device on a flat and clean surface.

VUE ÉCLATÉE / EXPLODED VIEW

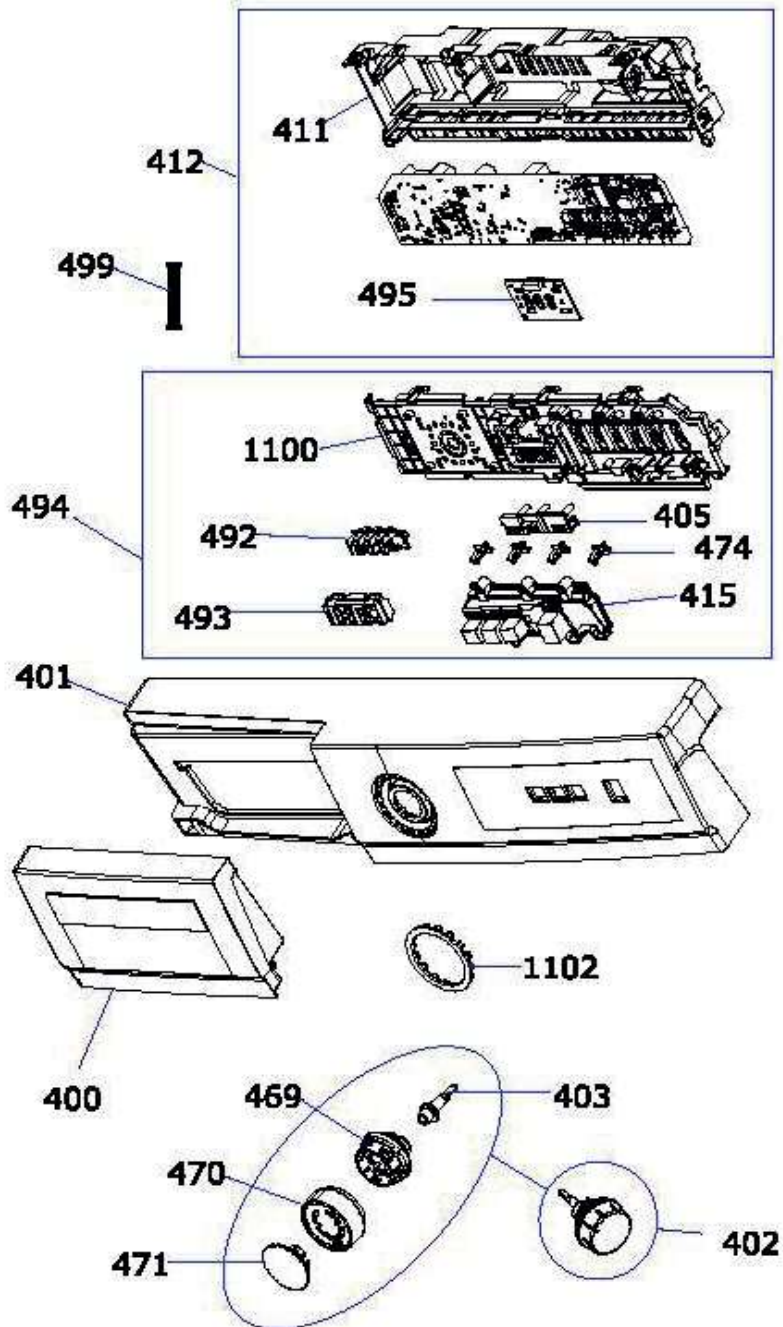

Toutes les informations, dessins, croquis et images dans ce document relèvent de la propriété exclusive de SOURCING & CREATION. SOURCING & CREATION se réserve tous les droits relatifs à ses marques, créations et informations. Toute copie ou reproduction, par quelque moyen que ce soit, sera jugée et considérée comme une contrefaçon.

All information, designs, drawings and pictures in this document are the property of SOURCING & CREATION. SOURCING & CREATION reserves all rights to its brands, designs and information. Any copy and reproduction through any means shall be deemed and considered as counterfeiting.

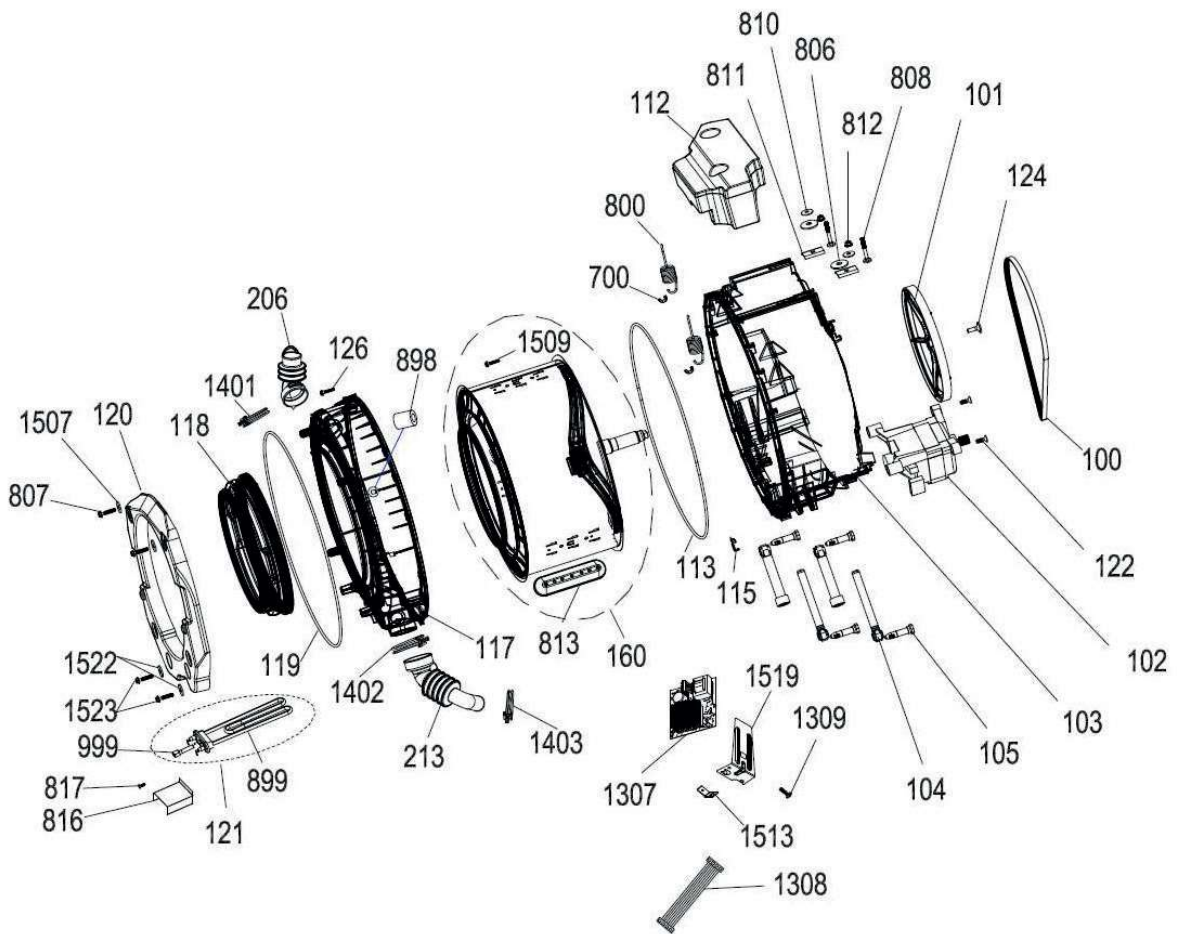
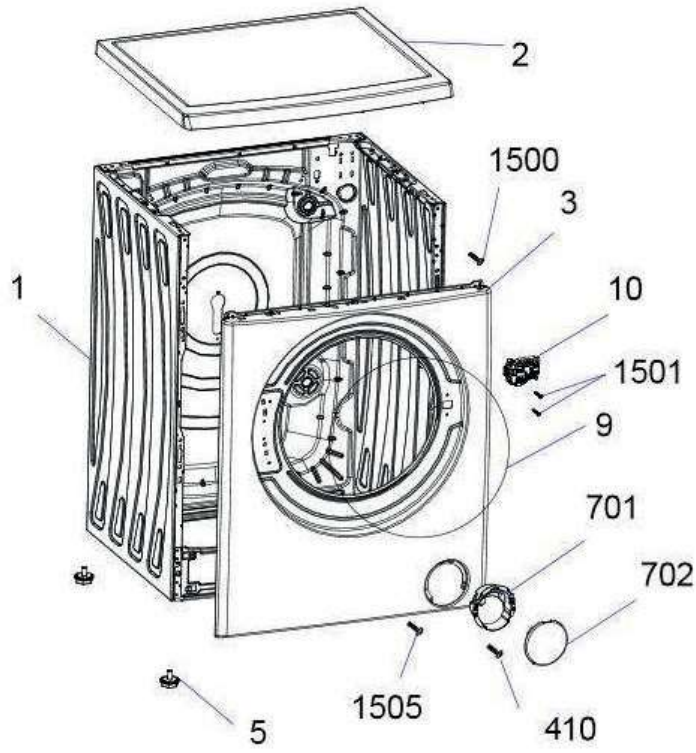

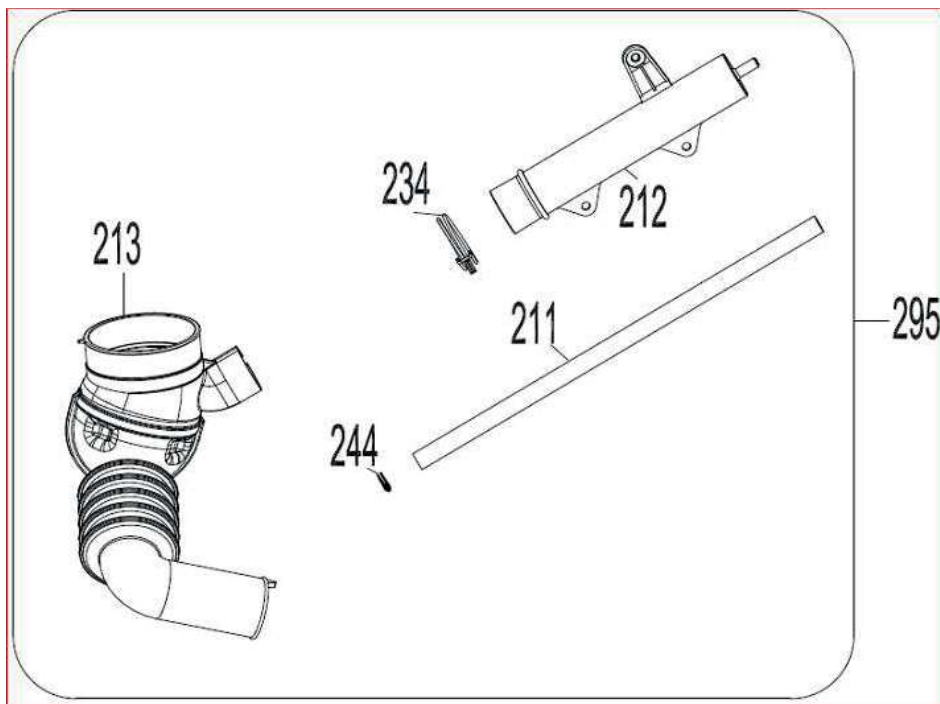
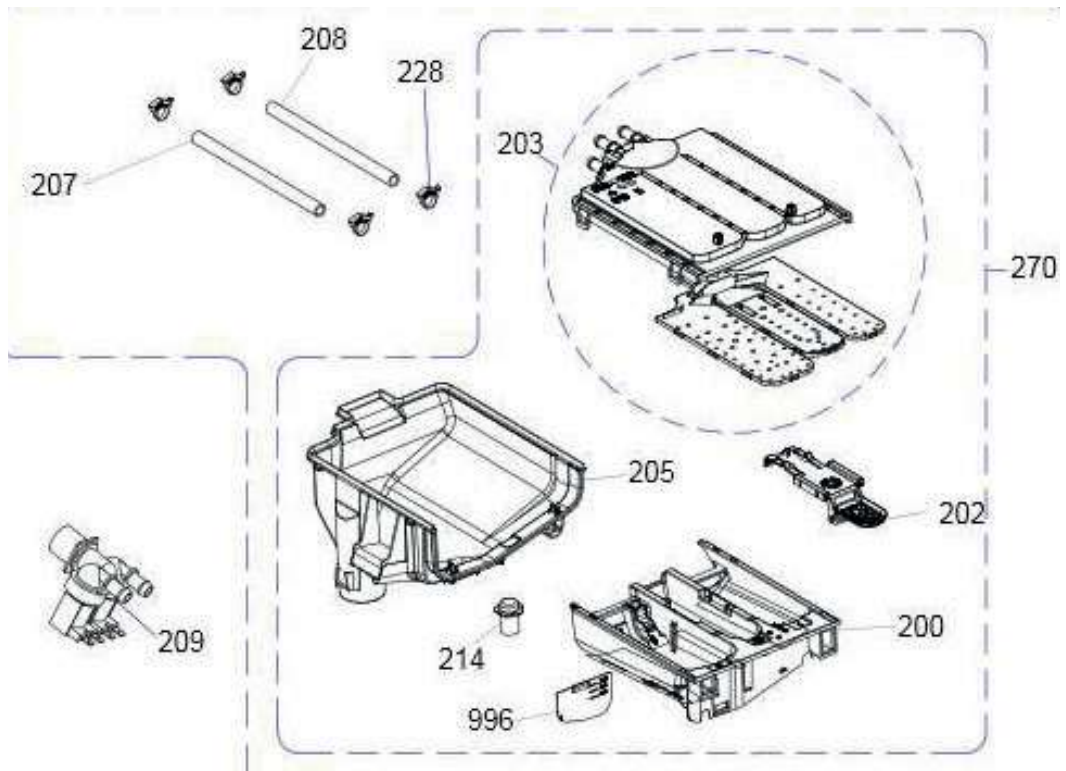

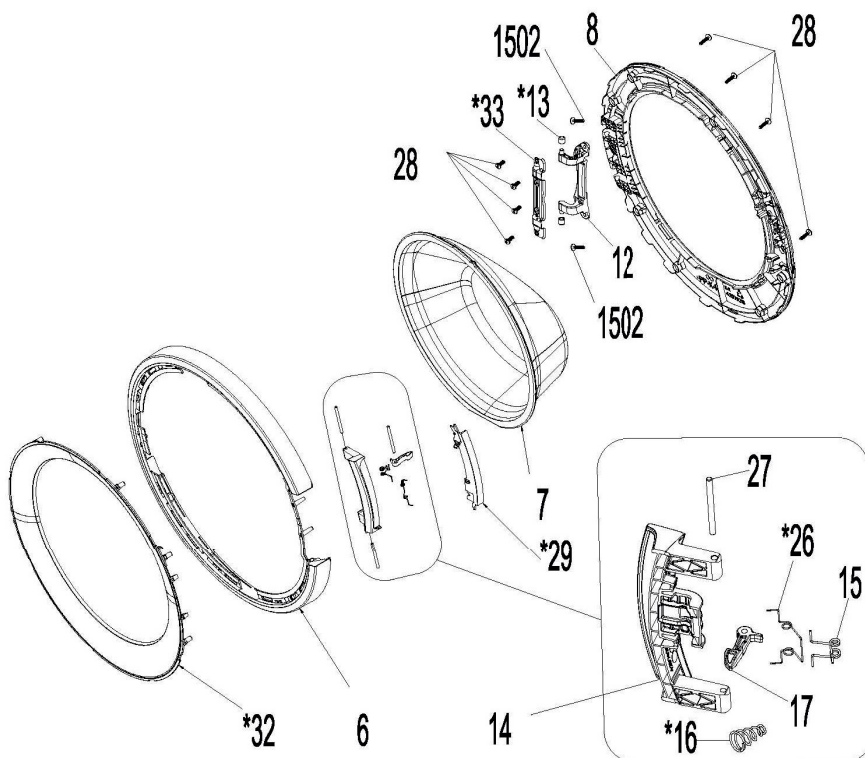
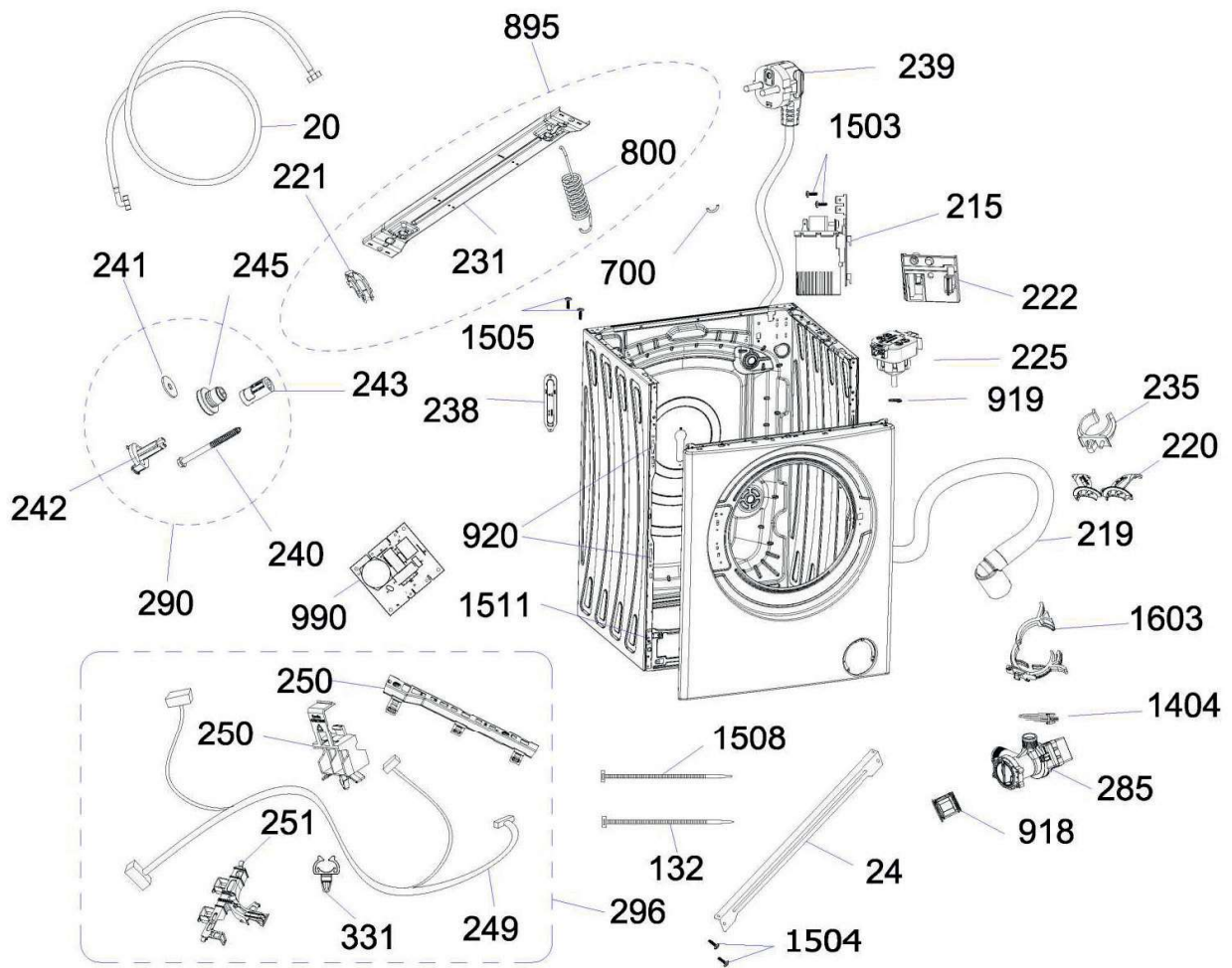



995



996

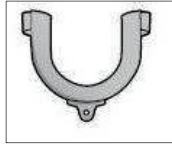

997



998

PIÈCES DÉTACHÉES / SPARE PARTS

N° VUE	REF PIECE	DESIGNATION (FR)	DESIGNATION (ENG)
1	20813487	MEUBLE	CABINET ASSEMBLY
2	42028889	DESSUS COUVERCLE	TOP FRAME ASSEMBLY
3	22179609	FACADE AVANT	FRONT PANEL
5	22035571	PIED	FEET
7	47003030	HUBLOT VERRE D310MM	DOOR GLASS D310MM
8	42125292	CONTRE PORTE HUBLOT	DOOR INSIDE FRAME
9	37008604	COLLIER JOINT HUBLOT/MEUBLE *	DOOR GASKET FIXING RING
10	32035412	SECURITE PORTE 3COSSES	DOOR LOCK
12	37016846	CHARNIERE HUBLOT	DOOR HINGE
13	42030372	AXE CHARNIERE HUBLOT (UNITAIRE)	HINGE AXIS ASSEMBLED DOOR
14	42196609	POIGNEE HUBLOT	DOOR HANDLE
15	35007443	RESSORT POIGNEE PORTE	DOOR HANDLE SPRING
17	37008931	CROCHET POIGNEE HUBLOT	DOOR HANDLE HOOK
20	40014423	TUYAU ARRIVEE D'EAU	HOSE -WATER INLET
24	22183972	TRAVERSE SUPERIEURE	UPPER SUPPORT BRACKET
26	37014985	RESSORT POIGNEE HUBLOT	HOOK SPRING
27	35007434	AXE CROCHET POIGNEE PORTE LG 50.78MM D 3.86 MM	HANDLE HOOK AXIS
28	35008714	VIS FIXATION CUVE 3.5*9	SCREW 3,5X9
32	42196608	ENJOLIVEUR HUBLOT	DOOR OUTER PLASTIC D85
33	37016847	SUPPORT CHARNIERE HUBLOT	DOOR HINGE HOLDER
100	42025177	COURROIE 1234J5EL 5PJE1234	BELT 1234J5EL
101	22115425	POULIE TAMBOUR AXE=16mm	DRUM PULLEY (16MM)
102	32039406	MOTEUR KC 22MM SPOKE	MOTOR KC 22MM SPOKE
103	20689457	CUVE 1/2 ARRIERE	REAR TANK GROUP
104	47010522	AMORTISSEUR 80N	SHOCK ABSORBER LL 80N
105	42025094	AXE AMORTISSEUR	SHOCK ABSORBER PIN
112	47014993	LEST SUPERIEUR	COUNTER WEIGHT(UPPER)
113	42015077	JOINT 1/2 CUVE AV/CUVE ARR	TUB SEAL
115	37018738	CLIPS FIXATION RESISTANCE	RESISTANCE FIXING CLIP
117	42233532	CUVE 1/2 AVANT	TANK 1/2 FRONT
118	42020405	JOINT HUBLOT HE 47L 52L	DOOR GASKET
119	37008603	COLLIER JOINT HUBLOT/CUVE	CLAMP DOOR GASKET/TANK
120	47019634	LEST AVANT	COUNTER WEIGHT (FRONT)
121	20846083	RESISTANCE 1850W +SONDE	HEATING ELEMENT + SENSOR
122	37007899	VIS 8*28 THB	SCREW 8X28
124	22227543	ECROU + RONDELLE - POULIE TAMBOUR SK	DRUM PULLEY NUT + WASHER
126	37035819	VIS 1/2 CUVE AV/AR	SCREW 1/2 TANK FRONT/BOTTOM
132	42048113	COLLIER	PLASTIC CLAMP
160	22006717	TAMBOUR 44 1200T/1400T	DRUM 44 1200T/1400T
200	42185103	BOITE LESSIVE COMPLETE SLIM	DETERGENT BOX ASSEMBLED
202	42185070	SYPHON BLEU (ASSOULISSANT)	SYPHON
203	42076624	BOITE LESSIVE COMPLETE SLIM	DETERGENT BOX ASSEMBLED
205	42076624	BOITE LESSIVE COMPLETE SLIM	DETERGENT BOX ASSEMBLED
206	42087110	DURITE BOITE LESSIVE / CUVE	TUB INLET HOSE.
207	42004536	DURITE ELECTROVANNE/BAC 220mm	HOSE VALVE/DETERGENT BOX 220MM
208	42004535	DURITE ELECTROVANNE/BAC 200mm	HOSE VALVE/DETERGENT BOX 220MM
209	32035767	ELECTROVANNE 2VOIES	WATER INLET VALVE
211	42078599	DURITE PRESSOSTAT 577mm	PRESSURE SWITCH HOSE L=577MM
212	42259234	CHAMBRE COMPRESSION	COMPRESSION CHAMBER
213	42127585	DURITE CUVE/POMPE DE VIDANGE	TUB FILTER HOSE ASSEMBLY COMPLETE
214	42185061	SYPHON BLEU	SYPHON

N° VUE	REF PIECE	DESIGNATION (FR)	DESIGNATION (ENG)
215	32027178	CONDENSATEUR ANTIPARASITE DNF06-P 2x2mH+0.47UF+1UF	INTERFERENCE SUPPRESSOR DNF06-P 2x2mH+0.47UF+1U
219	42074837	TUYAU DE VIDANGE	HOSE DRAIN PUMP
220	42019322	SUPPORT TUYAU DE VIDANGE	DISCHARGE HOSE HOLDER
221	42016727	ENTRETOISE RESSORT/MEUBLE	SPRING HANGER SHEET
222	42022768	SUPPORT PRESSOSTAT	PRESSURE SWITCH HOLDER
225	32025730	PRESSOSTAT ELECTRONIQUE	ELECTRONIC PRESURE SWITCH
228	42225796	SUPPORT TUYAU	HOSE HOLDER
231	22183978	SUPPORT RESSORT SUSPENSION	SUPPORT SPRING SUSPENSION
234	37027058	COLLIER POMPE VIDANGE/TUYAU VIDANGE 34.1	DRAIN PUMP CLAMP
235	40014270	COLLIER TUYAU VIDANGE	HOSE DRAIN CLAMP
238	42236479	CACHE ARRIERE VIS POULIE TAMBOUR	REAR COVER PULLEY SCREW
239	32016715	CABLE ALIMENTATION 3G1	POWER CORD ASSY.
241	37015272	RONDELLE VIS POULIE TAMBOUR 29*8*2	WASHER SCREW DRUM PULLEY
244	35008991	COLLIER DURITE PRESSOSTAT	PRESSURE SWITCH HOSE CLAMP
250	42093407	SUPPORT	HOLDER
251	42028367	SUPPORT CABLAGE	WIRING HOLDER
270	42185103	BOITE LESSIVE COMPLETE SLIM	DETERGENT BOX ASSEMBLED
285	32048313	POMPE DE VIDANGE LEILI BPX132-6L 132MM	DRAIN PUMP LEILI BPX132-6L 132MM
290	37023467	KIT BRIDAGE (UNITAIRE)	TRANSPORT SAFETY ASSEMBLY
295	42079698	DURITE CUVE/POMPE VIDANGE + CHAMBRE COMPRESSION + TUYAU PRESSOSTAT	TANK/DRAIN PUMP HOSE + COMPRESSION CHAMBER + PRESSURE SWITCH HOSE
296	32049825	CABLAGE	WIRING
400	42313629	FACADE TIROIR LESSIVE	DETERGENT DRAWER FRONT
401	42305597	BANDEAU LF714-L1B LISTO	CONTROL PANEL LF714-L1B LISTO
402	42219658	MANETTE PROGRAMME	PROGRAM SELECTOR ASSEMBLY
403	42161575	AXE MANETTE PROGRAMME	PROGRAM SELECTOR AXIS
405	42197370	TRANSFERT T1 T30	LIGHTGUIDE T1 T30
410	37016360	VIS 4*12 TORX	SCREW 4X12 TORX
411	42187918	BOITIER SUPPORT PLATINE	HOLDERBOX BOARD
412	22324608	PLATINE T1 6A8BFFF820200000 V0210-A/22B-G	E.CARD T1 6A8BFFF820200000 V0210-A/22B-G
415	42197363	BOUTON SELECTION T0-T1 T30	SELECTION BUTTON T0-T1 T30
474	42187938	ENTRETOISE BOUTON DE SELECTION	SELECTOR KNOB SPACER
492	42187929	GUIDE CACHE TRANSFERT	LIGHT GUIDE
493	42187931	CACHE TRANSFERT	LIGHT GUIDE COVER
495	22149331	PLATINE DISPLAY T1/T2 EGO	DISPLAY CARD T1/T2 EGO
499	32035097	CABLE COMMUNICATION	COMMUNICATION CABLE
700	42019298	DOUILLE RESSORT/CUVE	SOCKET SPRING/TANK
701	42187827	SUPPORT CACHE POMPE	PUMP COVER HOUSING
702	42187826	CACHE POMPE	PUMP COVER
800	37008404	RESSORT SUSPENSION CUVE	SUSPENSION SPRING
806	35007454	RONDELLE POULIE 28*8*3	WASHER SCREW PULLEY
807	37032828	VIS LEST AVANT 10*40	SCREW 10X40-COUNTERWEIGHT (FRONT)
808	37003063	VIS LEST SUPERIEUR	SCREW-COUNTERWEIGHT (UPPER)
810	37006960	RONDELLE 28x9x2	WASHER 28x9x2
811	37000507	ENTRETOISE LEST SUPERIEUR	UPPER COUNTERWEIGHT SPACER
812	37006921	ECROU M8	M8 FLANGED NUT
813	42148896	AUBE (unitaire)	AGITATOR
899	32004582	RESISTANCE 1850W	HEATING ELEMENT
918	42268876	BOUCHON POMPE LEILI	PLUG PUMP LEILI
920	42020456	CLIPS PANNEAU AVANT	CLIPS FRONT PANEL
996	42185073	KIT LESSIVE LIQUIDE	LIQUID DETERGENT KIT

N° VUE	REF PIECE	DESIGNATION (FR)	DESIGNATION (ENG)
997	40020601	CROSSE TUYAU DE VIDANGE	DRAIN HOSE HOLDER
998	42161854	CACHE BRIDAGE	REAR COVER CAP
999	32025771	SONDE RESISTANCE	NTC TEMPERATURE SENSOR
1100	42187917	SUPPORT TRANSFERT-BOUTON	PCB BOX REAR COVER
1102	42205074	INSERT TRANSFERT	LIGHTGUIDE INSERTY
1200	22132295	SUPPORT CHARNIERE	HINGE HOLDER
1307	22307668	PLATINE MOTEUR KC22 V1104 0807451214/2/S	MOTOR CARD KC22 V1104 0807451214/2/S
1308	32023391	CABLE MOTEUR-PLATINE EGO BLDC 1308	MOTOR CARD CABLE EGO BLDC 1308
1308	32040417	CABLE EGO BLDC 1316	CABLE EGO BLDC 1316
1309	37016371	VIS M4x8	SCREW M4x8
1401	37011009	COLLIER DURITE BOITE LESSIVE/CUVE	HOSE CLAMP
1402	35007369	COLLIER DURITE CUVE POMPE coté cuve + vis 72mm	HOSE CLAMP + SCREW 72MM
1403	37027638	COLLIER DIAM 38.8mm	HOSE CLAMP (ø 38,8)
1500	37015098	VIS 4.8x9.5	SCREW 4,8X9,5
1501	37014455	VIS 4.2*16	SCREW 4,2X16
1502	37035481	VIS CHARNIERE HUBLOT M5*8	SCREW HINGE DOOR M5*8
1504	37014453	VIS 4.2*13	SCREW 4,2X13
1507	37019417	RONDELLE POULIE 30*10*3	WASHER 30*10*3
1508	40007592	SUPPORT CABLE	WIRING HOLDER
1511	42088991	ENTRETOISE PANNEAU AVANT	FRONT PANEL SPACER
1513	32018631	COSSE MALE	MALE TERMINAL
1519	37047705	SUPPORT	SUPPORT SPRING SUSPENSION
1522	37000539	RONDELLE 36x23x2	WASHER 36x23x2
1523	37002601	VIS	SCREW
1603	42026116	SUPPORT TUYAU	HOSE HOLDER

CODES ERREURS / ERRORS CODES (ET/OU AND/OR) RÉOLUTIONS DES PROBLÈMES / TROUBLESHOOTING

Error Indication	Error Number	Indication For User	Indication For Service
		Yes/No	Yes/No
Door is not locked	E01	Yes	Yes
Door is unlocked during programme	E01	Yes	Yes
Lack of water	E02	Yes	Yes
Pump failure	E03	Yes	Yes
Overflow	E04	Yes	Yes
NTC or Heater Failure	E05	No	Yes
Motor Failure - 1 (Tachometer open-short circuit or motor connector is disconnected)	E06	No	Yes
Configuration Failure	E07	No	Yes
Motor Triac Failure	E08	No	Yes
Voltage Error	E09	Yes	Yes
Electronic Pressure Sensor	E10	No	Yes
Dryer Card Communication Error	E11	No	Yes
3D Communication Error	E12	No	Yes
LCD Communication Error	E13	No	No
Dryer Resistance Failure	E14	No	Yes
Twinjet Failure	E15	No	No
High Temperature Error	E16	No	Yes
Flowmeter Failure	E17	No	Yes
Dryer NTC Failure	E18	No	Yes
BLDC Failure	E19	No	Yes
Pyrojet Failure	E20	No	Yes
Detergent Dosage Pump Failure	E21	No	Yes
Softener Dosage Pump Failure	E22	No	Yes
Communication Failure Between PCB and BLDC Card	E23	No	Yes
Wrong LCD Software	E50	No	Yes
Wrong BLDC Software	E51	No	Yes

**Some of the error codes can not be seen based on changing the product types*

All repairs which must be done on the machine should be done by authorized agents only. When a repair is required for machine or you are unable to eliminate the failure with the help of the information given below:

- Unplug the machine.
- Close the water tap.

FAILURE	PROBABLE CAUSE	METHODS OF ELIMINATION
Machine does not operate.	It is unplugged.	Insert the plug into the socket.
	Fuse is defective.	Change fuse.

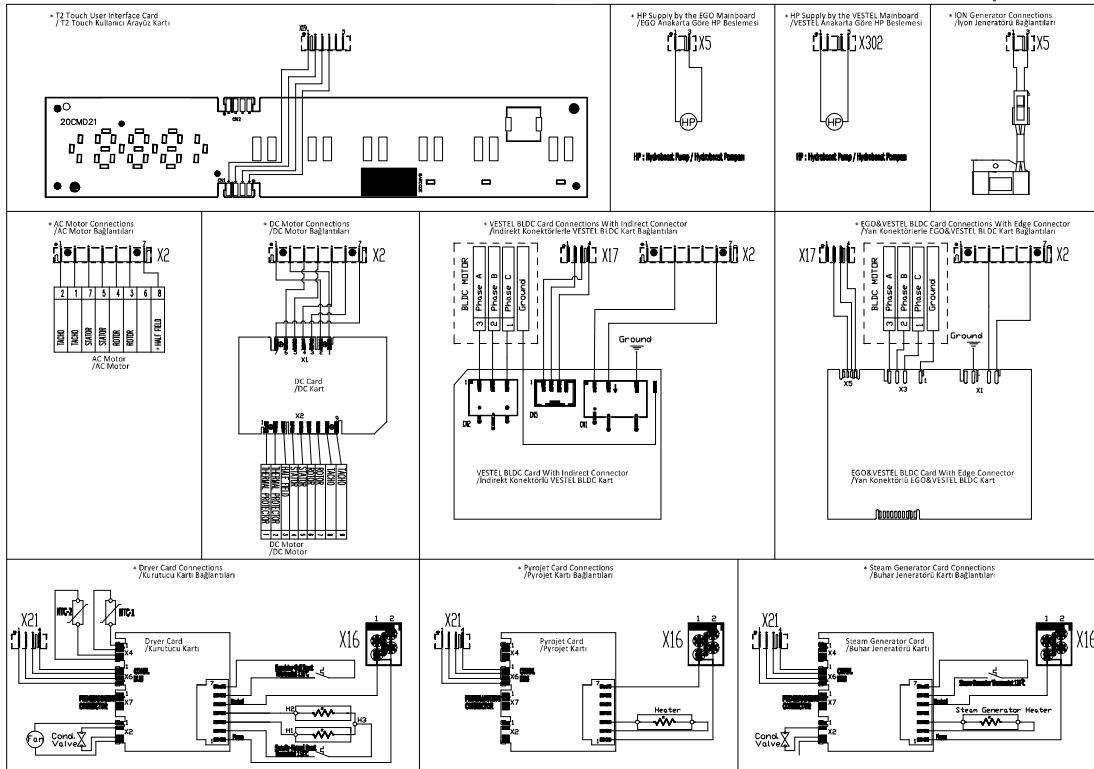
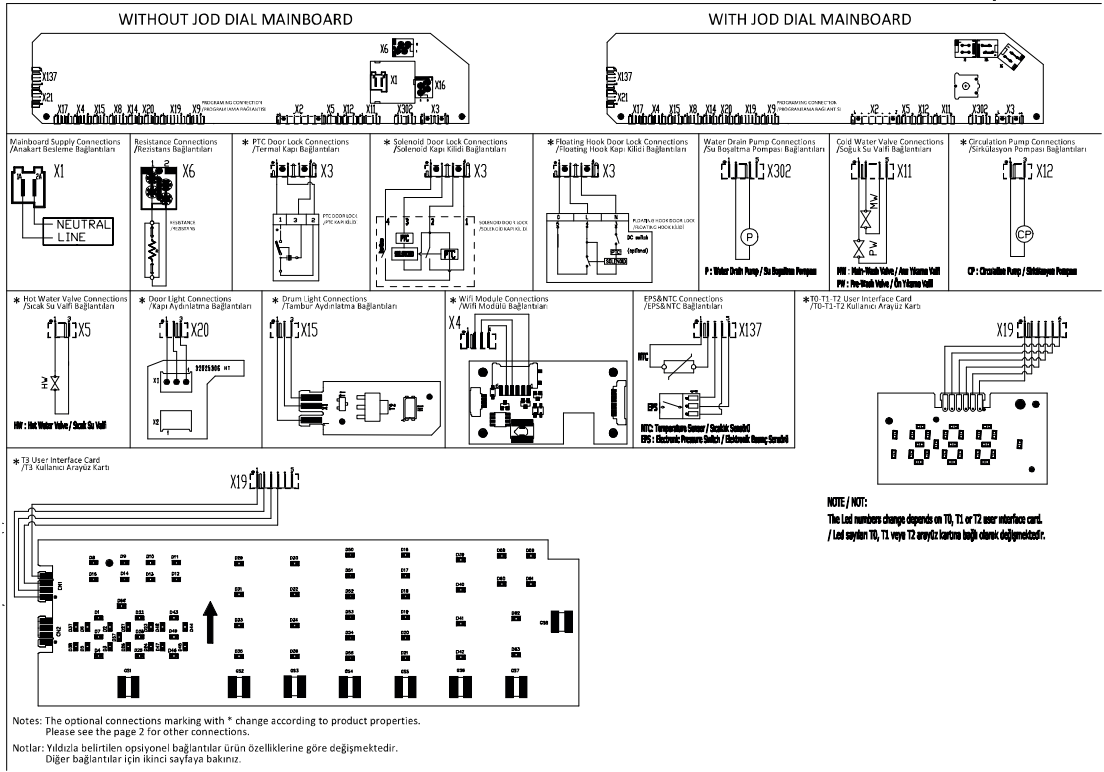

	Start / Pause button has not been pressed.	Press the start / pause button.
	The program knob is in 0 (off) status.	Bring the program knob on the desired status.
	The door is not shut properly.	Shut the door properly. You should hear the click.
	Child lock is active.	See page 9.
Machine does not receive water.	Water tap is closed.	Open water tap.
	The water inlet hose may be bent.	Check the water inlet hose.
	The water inlet hose is obstructed.	Clean the filters of water inlet hose.
	The water inlet filter is obstructed.	Clean the valve inlet filters.
Machine is not draining water.	The door is not shut properly.	Shut the door properly. You should hear the click.
	The drain hose is obstructed or bent.	Check the drain hose.
	The pump filter is obstructed.	Clean the pump filter.
	The clothes are not placed inside the machine in a well-balanced manner.	Spread the clothes inside the machine in an orderly and well-balanced manner.
Machine is vibrating.	The feet of machine are not adjusted.	Adjust the feet.
	Transportation screws are not removed.	Remove transportation screws.
	There is a small amount of clothes in the device.	It does not prevent operation of the machine.
	Excessive amount of clothes are filled in the machine or the clothes are not placed in a well-balanced manner.	Do not exceed the recommended quantity of clothes and spread clothes in the machine in a well-balanced manner.
Excessive foam in the detergent drawer	Too much detergent has been used.	Press the start/pause button. In order to stop the foam, dilute one table-spoon of softener in half liter of water and pour it in the detergent drawer. Press the start/pause button after 5-10 minutes. Arrange the amount of the detergent properly in the next washing process.
	Wrong detergent has been used.	Use only the detergents produced for full automatic machines.
The washing result is bad.	Laundry too dirty for the program you have selected.	Select a suitable program.
	The amount of detergent used is not sufficient.	Use more detergent according to the detergent.
The washing result is not good.	Clothes exceeding the maximum capacity has been filled in machine.	Put the clothes in machine in a manner not to exceed its maximum capacity.
	Water may be hard.	Use the amount of detergent according to the declaration of the detergent producer.
	Distribution of the clothes in machine is not well-balanced.	Spread the clothes inside the machine in an orderly and well-balanced manner.
The water is seen in the drum during washing.	No failure. The water is at the lower part of the drum.	
There are residues of detergent on the clothes.	The pieces of some detergents which do not dissolve in water may stick to clothes as white stains.	By calibrating machine for "Rinsing" program, make an additional rinsing or eliminate the stains After drying with the help of a brush.
There are grey stains on the clothes.	These stains may be caused by oil, cream or ointment.	In the next washing operation, use the maximum detergent amount declared by the detergent producer.
The spinning process is not done or starts with delay.	No failure. The unbalanced load control works in that way.	The unbalanced load control system will try to distribute clothes in a homogenous manner. After clothes are distributed, passage to spinning process will be realized. In the next washing process, place clothes into the machine in a well-balanced manner.

SCHÉMAS ÉLECTRIQUES ET ÉLECTRONIQUES / ELECTRIC AND ELECTRONIC DIAGRAMS



AUTORÉPARATION / SELF-REPAIR

Consignes de Sécurité

	<ul style="list-style-type: none">• Le symbole de l'éclair dans un triangle équilatéral attire l'attention de l'utilisateur sur la présence, dans le boîtier de l'appareil, d'une tension élevée, non isolée, dont l'amplitude pourrait être suffisante pour constituer un risque de décharge électrique sur les personnes.• The lightning in a triangle symbol is to warn the user of an uninsulated high voltage in the device's system that could be strong enough to pose an electric shock hazard for people.
	<ul style="list-style-type: none">• Le point d'exclamation inscrit dans un triangle équilatéral attire l'attention de l'utilisateur sur la présence de consignes de sécurité importantes de fonctionnement ou de maintenance (entretien courant) dans la notice accompagnant l'appareil.• The exclamation mark in a triangle symbol is used to draw the user's attention to key operational or maintenance (routine maintenance) safety instructions in the instructions accompanying the appliance.

- Travaillez dans un environnement dégagé et éloigné de toutes substances inflammables ou explosives à proximité de votre appareil.
- Ne manipulez pas l'appareil ou le cordon d'alimentation avec les mains mouillées.
- Portez un équipement de protection (gants, lunettes de sécurité, etc.) pour prévenir les blessures et les chocs électriques pendant l'entretien, le démontage ou la réparation de votre appareil.
- **Avant toute intervention d'entretien, de démontage ou de réparation :**
 - » **Débranchez les prises d'alimentation CA et/ou CC de votre prise secteur.**
 - » **Fermez l'arrivée d'eau. Débranchez le tuyau flexible d'alimentation en eau ainsi que le tuyau d'évacuation.**
- Ne tirez jamais sur le cordon d'alimentation pour le débrancher mais toujours au niveau de la fiche.
- Si le câble d'alimentation de votre appareil est endommagé, il doit être remplacé par votre revendeur, son service après-vente ou une personne de qualification similaire afin d'éviter tout danger. Ne mettez jamais l'appareil en marche si le cordon d'alimentation ou la prise est endommagé(e).
- Entretien: retirez les poussières ou tout corps étranger dans le produit, les câbles et les raccordements.
- Si vous devez coucher le lave-linge, posez le délicatement et uniquement sur le côté ou sur la face arrière en utilisant une protection au sol.
- Lorsqu'une ou des pièces doivent être changées, assurez-vous que le technicien a utilisé des pièces de rechange d'origine ou comportant les mêmes caractéristiques et les mêmes performances que celles-ci.
- Une pièce de remplacement qui ne possède pas les mêmes caractéristiques de sécurité que la pièce de remplacement recommandée peut provoquer un choc électrique, un incendie et/ou présenter d'autres dangers.
- Réinstallez les éléments démontés à leur emplacement d'origine. Vérifiez toujours que les vis, les composants et le câblage ont été correctement réinstallés.
- Assurez-vous que l'espace autour des pièces entretenues ou échangées n'a subi aucun dommage.
- Si vous utilisez un instrument de mesure, raccordez toujours un fil de terre de l'instrument de test à la mise à la terre du châssis de l'instrument avant de relier le fil positif ; retirez toujours le fil de terre de l'instrument en dernier.



Safety instructions

- Work in an open environment away from any flammable or explosive substances near your device.
- Do not handle the appliance or the power cord with wet hands.
- Wear protective equipment (gloves, safety glasses, etc.) to prevent injury and electric shock during maintenance, disassembly or repair of your device.
- **Before any maintenance, disassembly or repair work:**
 - » **Disconnect the AC and / or DC power plugs from your outlet.**
 - » **Turn off the water supply. Disconnect the water supply hose and the drain hose.**
- Never pull on the power cord to disconnect it, always at the plug.
- If the power cable of your appliance is damaged, it must be replaced by your dealer, its after-sales service or a similarly qualified person in order to avoid any danger. Never start the product if the power cord or plug is damaged.
- Remove dust or any foreign object in the product, cables and connections.
- If you have to lay the washing machine down, place it gently and only on its side or on the back, using a floor protection.
- When one or more parts must be changed, make sure that the technician has used spare parts that are original or have the same characteristics and performance as these.
- A replacement part that does not have the same safety characteristics as the recommended replacement part may provide electric shock, fire and / or other hazards.
- Reinstall the removed items in their original locations. Check that the components have always been correctly reinstalled.
- Make sure that the space around the serviced or exchanged parts has not been damaged.
- If you are using a measuring instrument, always connect a test instrument ground wire to the instrument chassis ground before connecting the positive wire; Always remove the ground wire from the measuring instrument last.

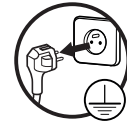

7.1. Top Plate

1. Remove two screws that fix the top-plate at the back.



2. Pull the door up.



2. Push the top-plate back and pull it up.



3. Remove screws that fix the door group.



7.2. Door

1. Remove two screws that fix the door. (by using the T25)



4. Put the door outside plastic with helping screwdriver as it is shown in the picture.

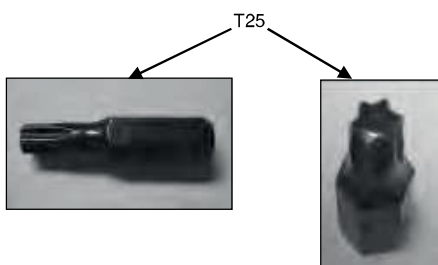

5. Remove the door inside plastic as it is shown in the picture.



8. Remove the door handle pin as it is shown in the picture.



6. Remove six screws that fix the door hinge as it is shown in the picture.



7. Remove the door handle as it is shown in the picture.



RAPPEL DES CONSIGNES ÉLÉMENTAIRES D'ENTRETIEN / REMINDER OF BASIC MAINTENANCE INSTRUCTIONS

Nettoyage de la surface extérieure de l'appareil

- Pour nettoyer l'extérieur de l'appareil, utilisez une éponge imbibée d'eau tiède savonneuse.
- N'utilisez pas de produits détergents abrasifs ni de solvants.
- Séchez soigneusement à l'aide d'un chiffon doux.

Nettoyage du tiroir à produits lessiviels

Il est recommandé de retirer régulièrement toute accumulation de résidus de détergent dans le tiroir à produits. Nettoyez celui-ci ainsi que ses accessoires (cloison séparatrice) tous les 4 à 5 cycles de lavage.

Pour cela, procédez comme suit :

1. Retirez le tiroir à produits en le tirant vers vous et en appuyant sur la zone encadrée comme indiqué sur le schéma ci-dessous.

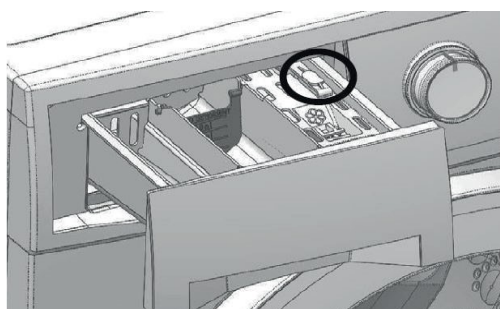

Lavez le tiroir à produits à l'eau tiède et avec une petite brosse à poils souples puis, séchez-le avec un chiffon doux.

2. Puis, remplacez le tiroir à produits dans son logement.

Nettoyage des filtres du tuyau d'arrivée d'eau

Un filtre se trouve à chaque extrémité du tuyau d'arrivée d'eau. Ces filtres empêchent les substances étrangères et la saleté qui se trouve dans l'eau de pénétrer dans l'appareil. Ces filtres doivent être nettoyés régulièrement.

1. Mettez le lave-linge à l'arrêt et débranchez le cordon d'alimentation.
2. Fermez le robinet.

1. Dévissez le tuyau d'arrivée d'eau à l'arrivée d'eau et au point de raccordement de l'appareil.
2. Extrayez les filtres ainsi que leurs joints et nettoyez-les soigneusement à l'eau du robinet avec une brosse adaptée. Si les filtres sont très sales, vous pouvez les retirer à l'aide d'une pince.
3. Remplacez soigneusement les filtres et les joints et resserrez soigneusement le tuyau à la main.

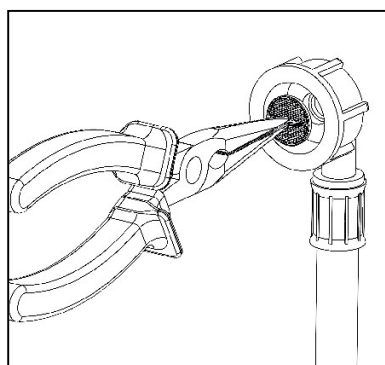
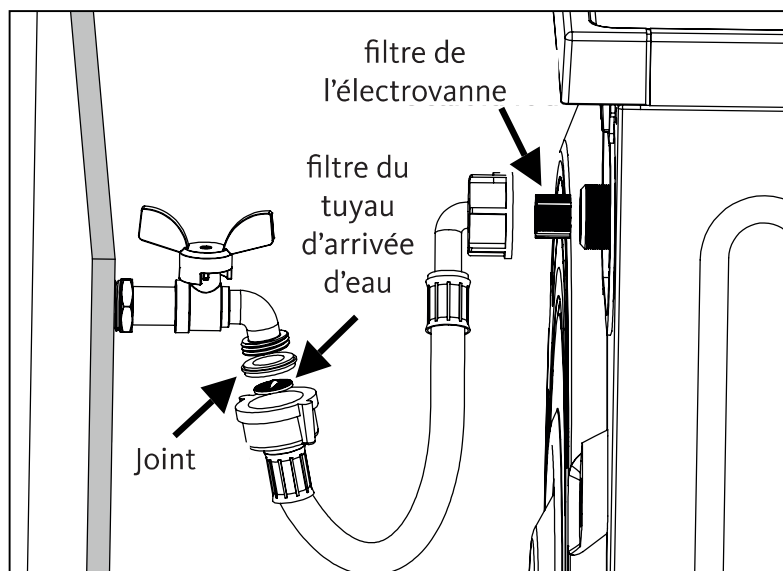

Retrait du filtre du tuyau d'arrivée d'eau

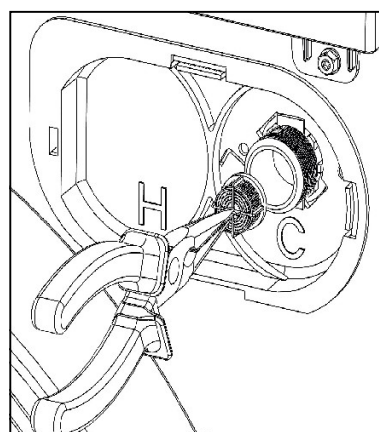

Retrait du filtre de l'électrovanne

Évacuation de l'eau restante et nettoyage du filtre de la pompe de vidange

Votre appareil est équipé d'un système de filtration qui empêche les éléments solides comme les boutons, les pièces, et les fibres de tissu, d'obstruer l'hélice de la pompe de vidange au cours de l'évacuation de l'eau.

Si votre appareil n'évacue pas l'eau, il se peut que le filtre soit obstrué. L'eau doit être vidangée manuellement afin de nettoyer le filtre de la pompe.

Par ailleurs, vous pouvez être amené à devoir évacuer l'eau complètement dans les cas suivants :

- avant de transporter l'appareil (en cas de déménagement par exemple),
- en cas de risque de gel.

Attention ! De l'eau à 90 °C peut se trouver dans le lave-linge. De ce fait, le filtre ne doit être nettoyé qu'après refroidissement de l'eau chaude qui se trouve à l'intérieur, afin d'éviter tout risque de brûlure.

1. Mettez le lave-linge à l'arrêt et débranchez-le.
2. Munissez-vous d'une pièce de monnaie et utilisez-la afin d'ouvrir la trappe.
3. Placez un récipient sous la trappe afin de recueillir l'eau résiduelle.

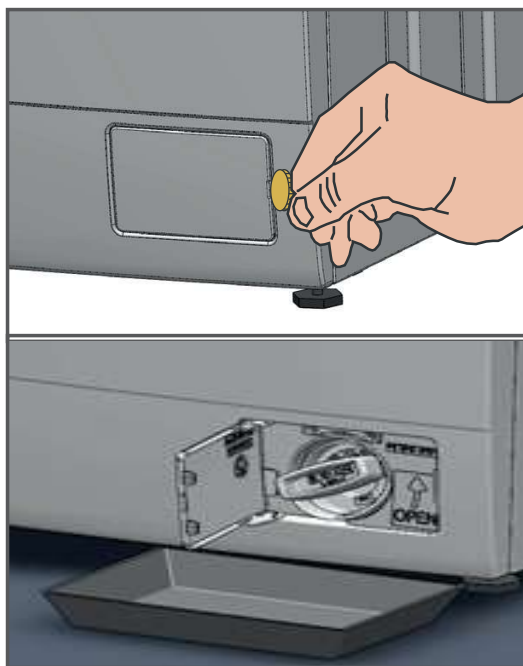

Important : en cas de blocage du circuit, la quantité d'eau peut être importante !

1. Dévissez légèrement le filtre afin que l'eau s'écoule.



2. Lorsque l'eau s'est écoulée, sortez complètement le filtre de son logement afin de le nettoyer. Retirez les éventuels corps étrangers.



3. Remettez le filtre en place en le vissant, puis refermez la trappe.

Attention : si vous ne réinstallez pas correctement le filtre, de l'eau s'écoulera du lave-linge !

Cleaning the exterior of the appliance

- To clean the appliance exterior, use a sponge soaked in warm soapy water.
- Do not use abrasive detergents or solvents.
- Dry thoroughly with a soft cloth.

Cleaning the detergent drawer

It is recommended that any accumulation of detergent residue be removed from the detergent drawer on a regular basis. Clean this and its accessories (separator) every 4 or 5 wash cycles.

To do this, proceed as follows:

1. Remove the detergent drawer by pulling it towards you and pressing on the area circled as shown on the following diagram.

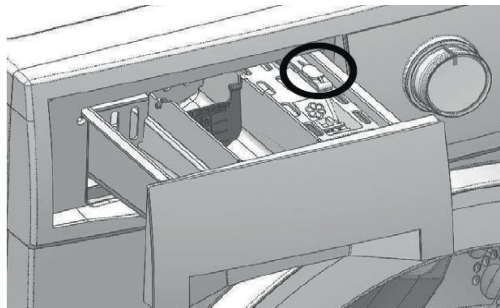

Wash the detergent drawer with warm water and a small, soft-bristled brush, then dry with a soft cloth.

2. Then replace the detergent drawer into its housing.

Cleaning the water supply hose filters

There is a filter at each end of the water supply hose. These filters prevent the foreign bodies and dirt found in water from penetrating the appliance. These filters must be cleaned regularly.

1. Stop the washing machine and unplug the power cord.
2. Turn off the tap.
3. Unscrew the water supply hose from the water inlet and washing machine connection point.
4. Remove the filters and their seals and clean these thoroughly using tap water and a suitable brush. If the filters are very dirty, you can remove them using pliers.

1. Replace the filters and seals carefully and re-tighten the hose carefully by hand.

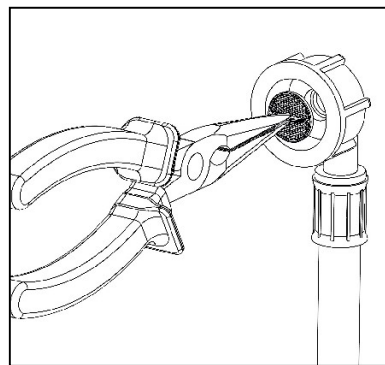
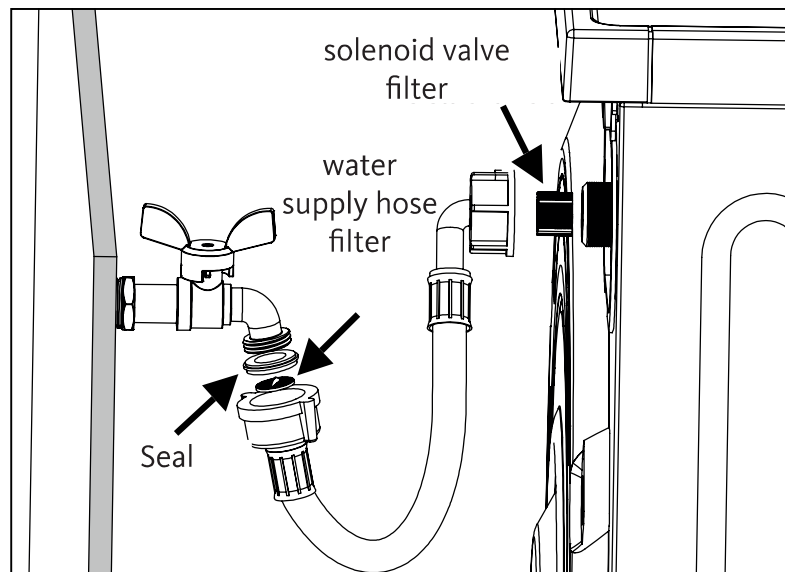

Removing the water inlet hose filter

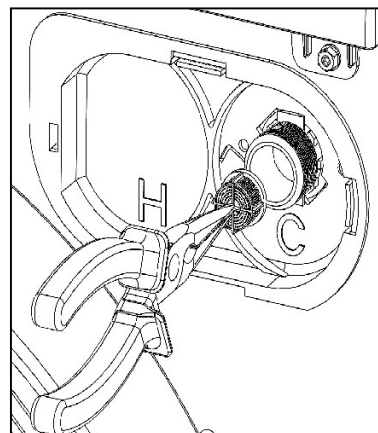

Removing the solenoid valve filter

Draining remaining water and cleaning the drain pump filter

Your appliance is equipped with a filtration system that prevents solid matter such as buttons, coins and fabric fibres from obstructing the drain pump blades when draining the water. If your appliance does not drain the water, the filter may be clogged. The water must be drained manually in order to clean the pump filter.

Furthermore, you may have to drain the water completely in the following cases:

- before transporting the appliance (if moving home, for example),
- if there is a risk of frost.

Caution: The washing machine may contain water at 90°C. As a result, the filter must only be cleaned after the hot water inside is cooled, in order to prevent any risk of burns.

1. Stop the washing machine and unplug the power cord.
2. Undo the cover using a coin.

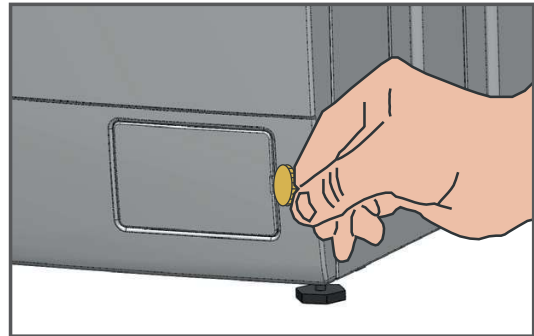

3. Place a container under the cover to collect the residual water.



Important: if the circuit is blocked, there may be a lot of water!

4. Unscrew the filter slightly so that the water runs.



5. When the water has run out, remove the filter completely from its housing in order to clean it. Remove any foreign bodies.

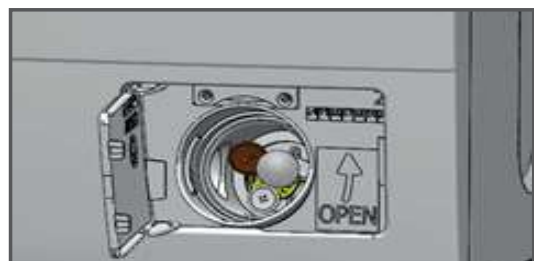

6. Replace the filter by screwing it up, then close the cover again.

Caution: If you do not reinstall the filter correctly, the water will run out of the washing machine!

Nos solutions Service après-vente Our after-sales service solutions

INTERNET

<https://www.boulanger.com/magasins/>



Je trouve mon magasin Boulanger

Code postal, ville, pays



Me géolocaliser



TELEPHONE

Contactez le 3011 depuis la France ou le 0 800 30 30 11 depuis l'étranger

Contact 3011 from France or 0 800 30 30 11 from abroad

Information :

- Numéros gratuits / Free numbers
- Accès sourds et malentendants / *Deaf and hard of hearing access*

Hors garantie, retrouvez la liste de réparateurs identifiés par l'ADEME à l'adresse : www.annuaire-reparation.fr

Out of warranty, find the list of repairers identified by ADEME at : www.annuaire-reparation.fr