

essentiel 

**Réfrigérateur intégrable / Built-in
refrigerator / Refrigerador empotrado /
Eingebauter Kühlschrank /
Ingebouwde koelkast**

ERLVI180-55mib3



Procédure d'inversion d'ouverture de la porte





Procédure d'inversion d'ouverture de la porte

Procedimiento de cambio de sentido de apertura de puerta

Vorgehen zur Umkehr der Türöffnungsrichtung

Werkwijze om de openingsrichting van de deur te veranderen

Inversion du sens de la porte

Liste des outils à fournir par l'utilisateur	
	
Tournevis cruciforme	Couteau à mastic, tournevis à lame fine
	
Cliquet et douille de 5/16 pouces	Ruban de masquage

- 1) Éteignez le réfrigérateur et retirez tous les objets des balconnets de porte.
- 2) Retirez la charnière supérieure et les cache-trous de la porte du réfrigérateur.

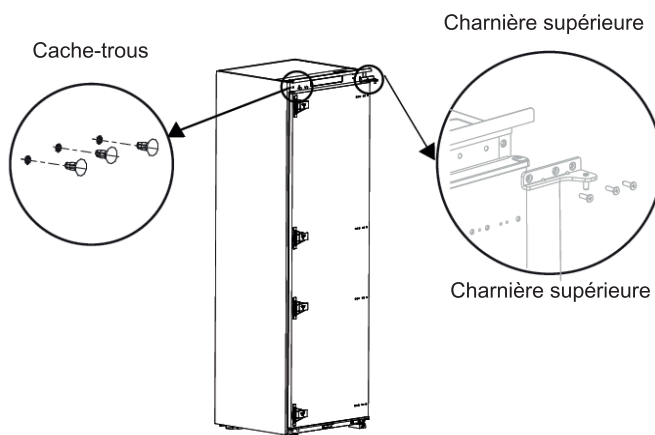

- 3) Retirez la porte du réfrigérateur, la charnière inférieure et les cache-trous.

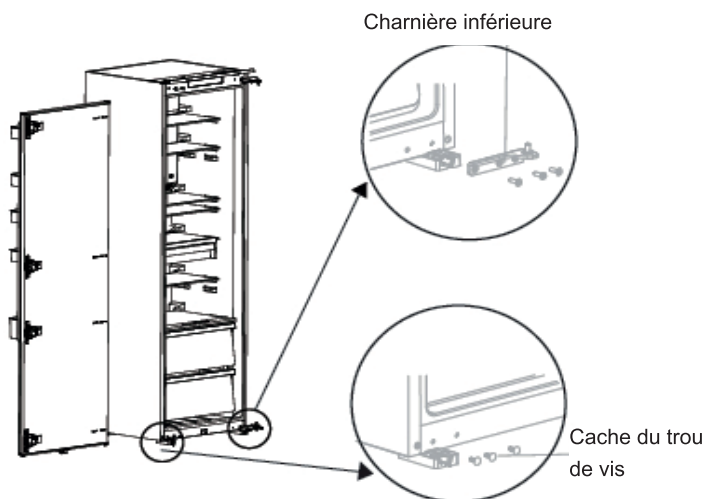

- 4) Échangez les charnières inférieure et supérieure, puis installez-les selon les étapes ci-dessous, et installez les cache-trous supérieurs.

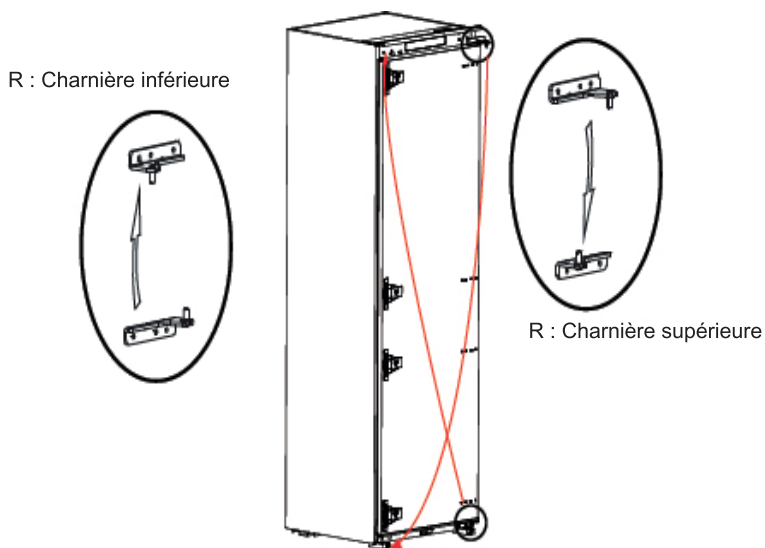

- 5) Retirez les deux blocs de fixation de la porte du réfrigérateur, tournez-les à 180° et installez-les de l'autre côté de la porte du réfrigérateur.

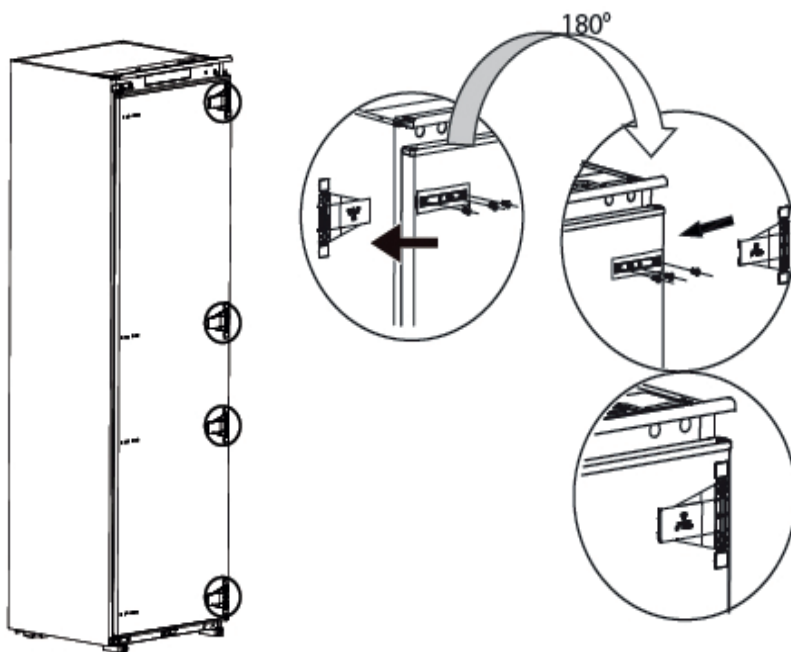



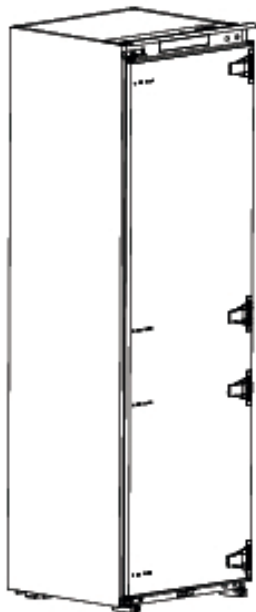

6) Ci-dessous se trouve l'image du résultat final



(L'illustration ci-dessus est fournie à titre indicatif uniquement. La configuration réelle dépend du modèle concerné ou des déclarations du distributeur)

Door Right-Left Change

List of tools to be provided by the user	
	
Cross screwdriver	Putty knife thin-blade screwdriver
	
5/16" socket and ratchet	Masking tape

- 1) Power off the refrigerator, and remove all objects from the door trays.
- 2) Remove the upper hinge and hole caps of refrigerator door.

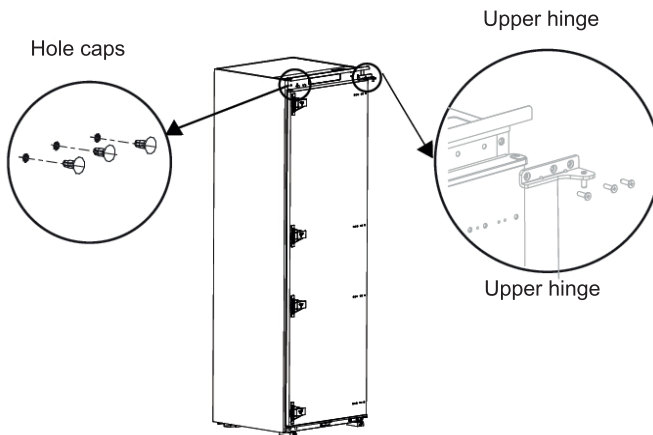

- 3) Remove the refrigerator door, the bottom hinge and the hole cover.

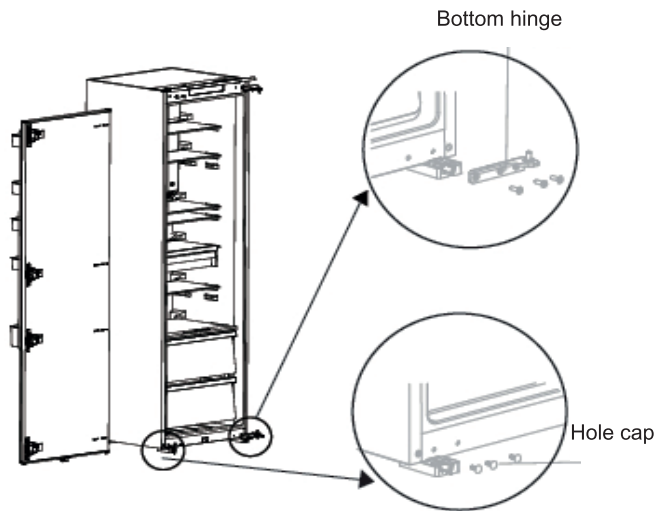

- 4) Exchange the R:bottom hinge and R:upper hinge, then install them according to below steps, and install the top hole caps.

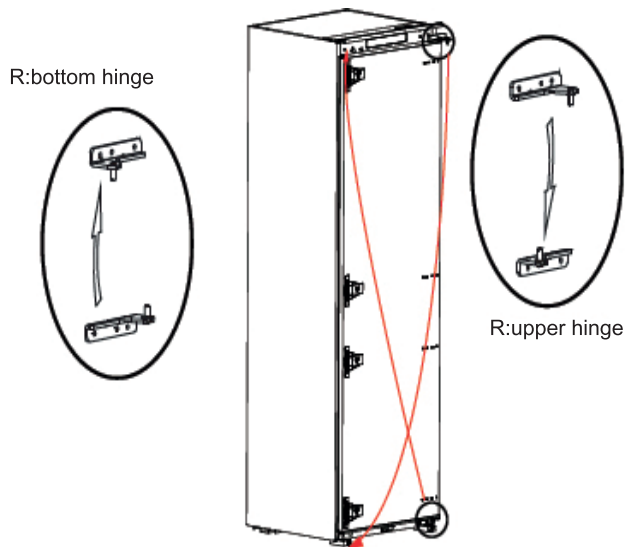

- 5) Remove the tow fixed blocks of refrigerator door and rotate them for 180°, and install them on other side of refrigerator door.

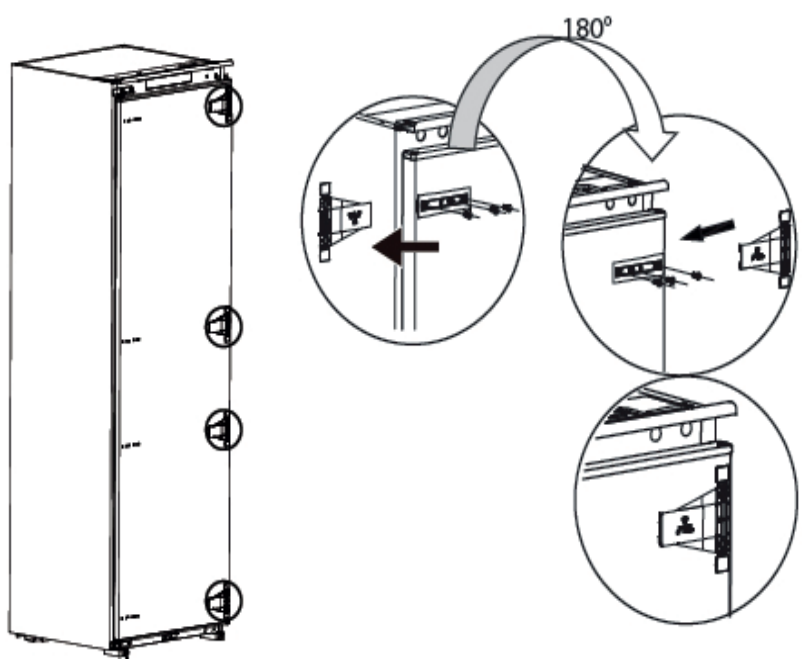

6) The picture after completion is shown as below

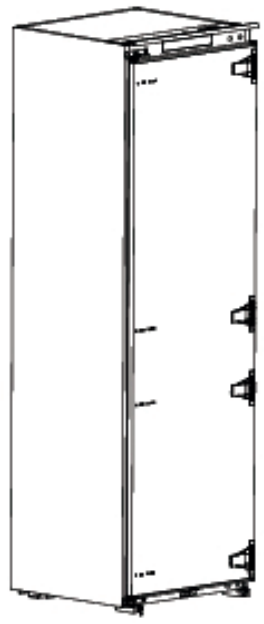

(The picture above is only for reference. The actual configuration will depend on the physical product or statement by the distributor)

Cambio de apertura de puerta de derecha a izquierda

Lista de herramientas necesarias	
	
Destornillador de estrella	Espátula destornillador plano
	
Llave de vaso y carraca de 5/16"	Cinta adhesiva

- 1) Apague el refrigerífico y saque todos los objetos de las bandejas de la puerta.
- 2) Retire la bisagra superior y las tapas de orificio de la puerta del refrigerífico.

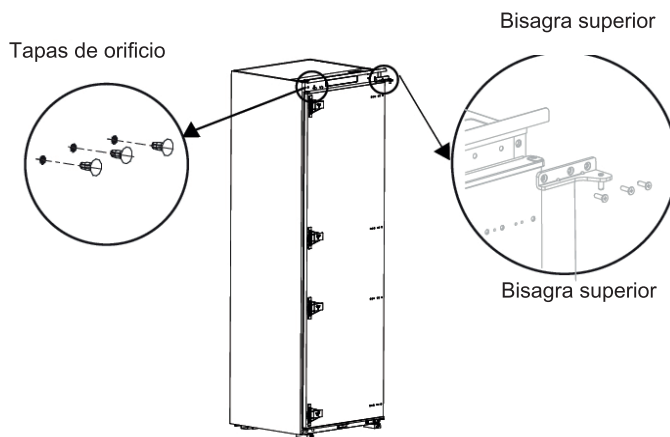

- 3) Retire la puerta del refrigerífico, la bisagra inferior y la tapa de orificio.

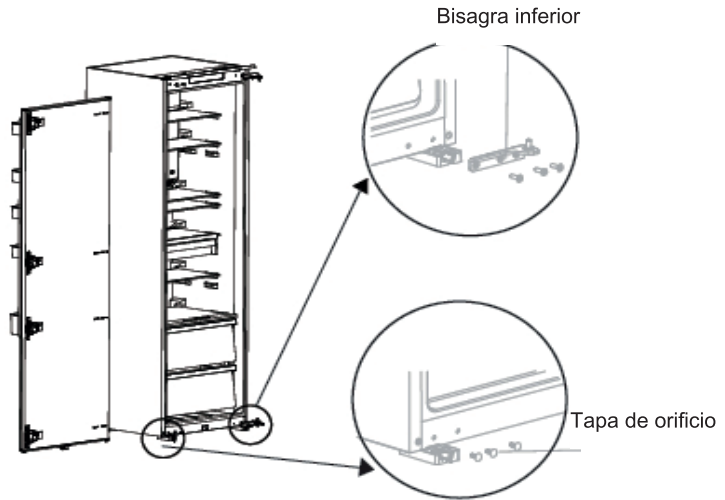

4) Cambie la R:bisagra inferior y la R:bisagra superior, después instálelas según los siguientes pasos, e instale las tapas de orificio superiores.

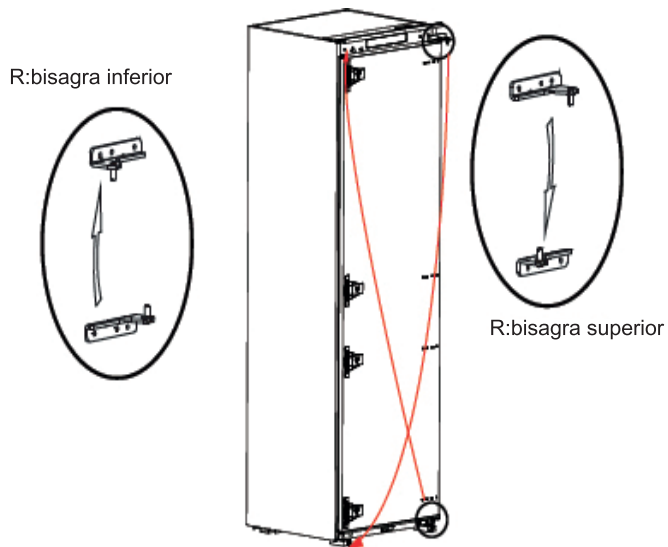

5) Retire los bloques fijos de remolque de la puerta del frigorífico y gírelos 180°, e instálelos en el otro lado de la puerta del frigorífico.

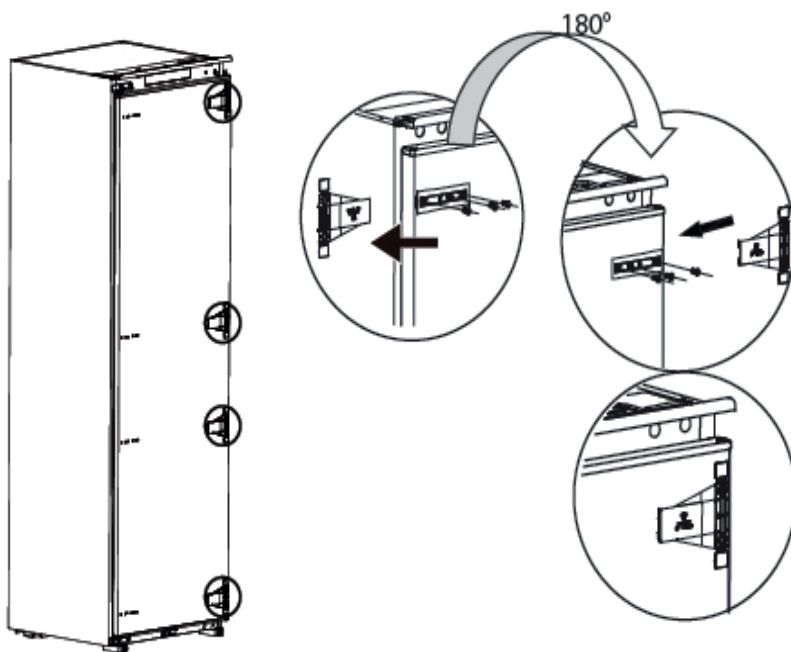



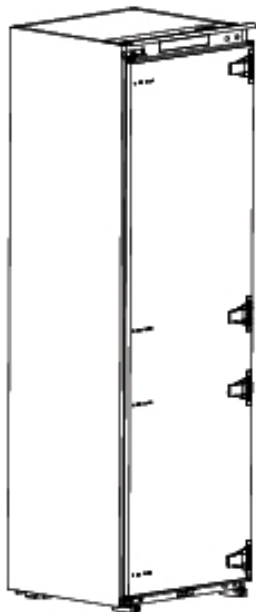

6) La imagen tras finalizar se muestra a continuación



(La imagen superior solo sirve de referencia. La configuración real dependerá del producto físico o de la declaración del distribuidor)

Umkehr der Türöffnung rechts links

Liste der vom Benutzer bereitzuhaltenden Werkzeuge	
	
Kreuzschraubenzieher	Schraubgriffspachtel mit dünner Klinge
	
5/16-Zoll-Steckschlüssel und Ratsche	Abdeckklebeband

- 1) Den Kühlschrank ausschalten und alle Gegenstände aus den Türfächern entfernen.
- 2) Das obere Scharnier und die Lochkappen der Kühlschranktür entfernen.

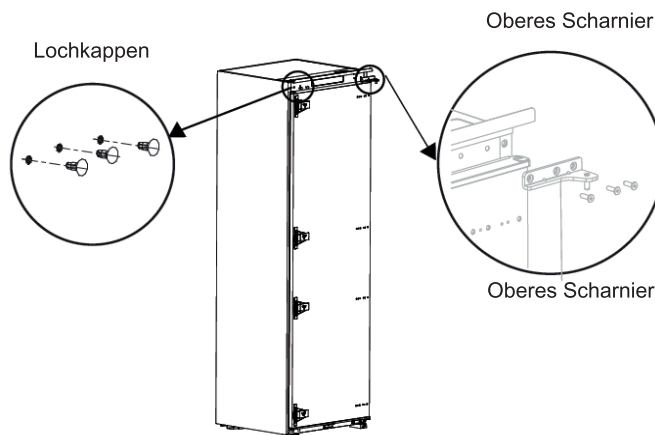

- 3) Die Kühlschranktür, das untere Scharnier und die Lochabdeckung entfernen.

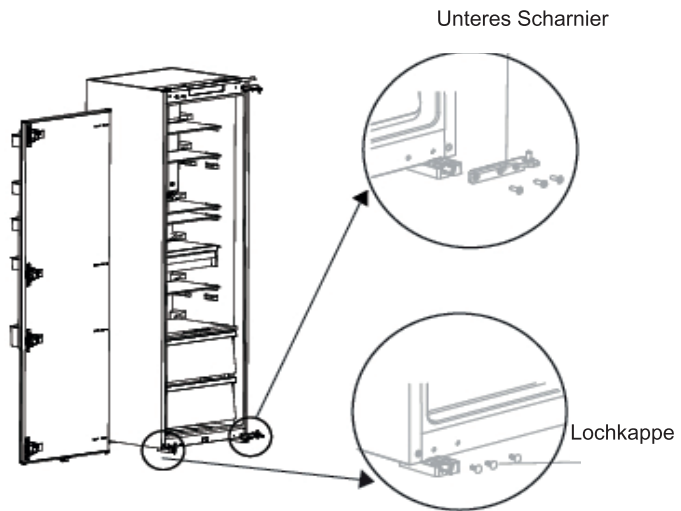

- 4) Das R:untere Scharnier und das R:obere Scharnier austauschen, diese sie dann wie unten beschrieben montieren und die oberen Lockkappen anbringen.

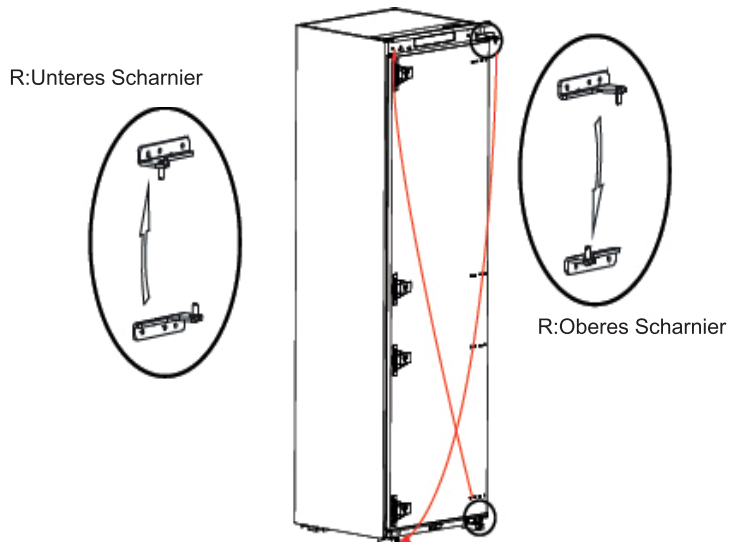

- 5) Die beiden festen Blöcke der Kühlschrantür entfernen, um 180° drehen und sie auf der anderen Seite der Kühlschrantür wieder anbringen.

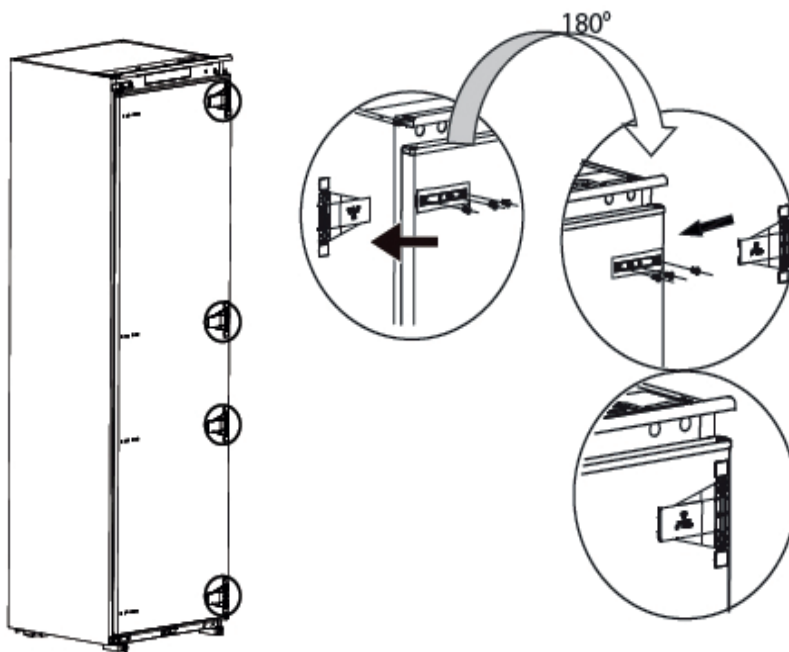



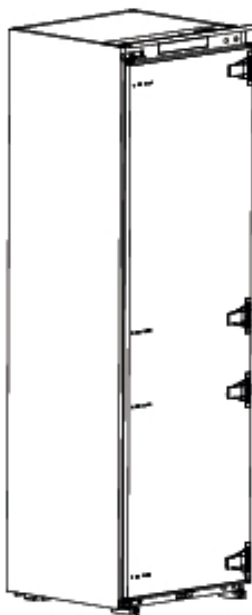

6) Ansicht nach Fertigstellung wie unten gezeigt



(Die Abbildung oben dient lediglich zur Veranschaulichung. Die tatsächliche Konfiguration hängt vom jeweiligen Produkt oder von den Angaben des Händlers ab)

Omkeren van de openingsrichting van de deur

Lijst van gereedschap dat de gebruiker moet voorzien	
	
Kruiskopschroevendraaier	Plamuurmes, platte schroevendraaier
	
5/16' ratelsleutel	Afplakband

- 1) Schakel de koelkast uit en verwijder alle voorwerpen uit de deurvakken.
- 2) Verwijder het bovenste scharnier en de afdekplaatjes van de koelkastdeur.

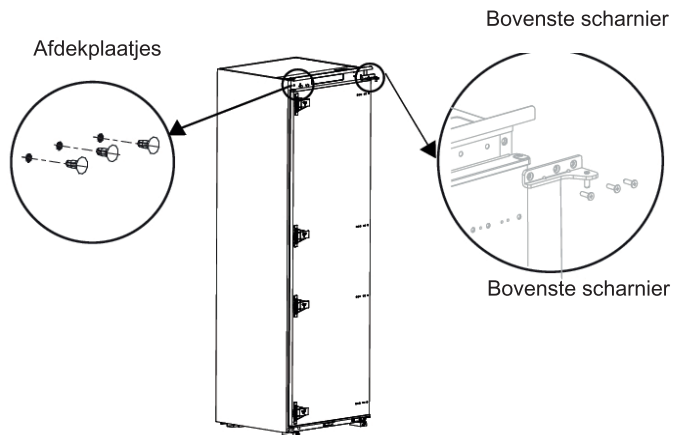

- 3) Verwijder het onderste scharnier, het afdekplaatje en de koelkastdeur.

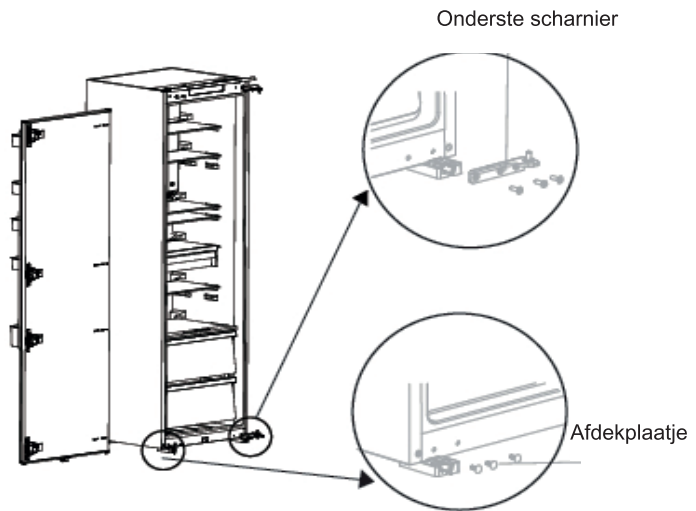

NL

4) Wissel het onderste scharnier rechts en het bovenste scharnier rechts om. Plaats ze dan opnieuw volgens onderstaande stappen en plaats de afdekplaatjes.

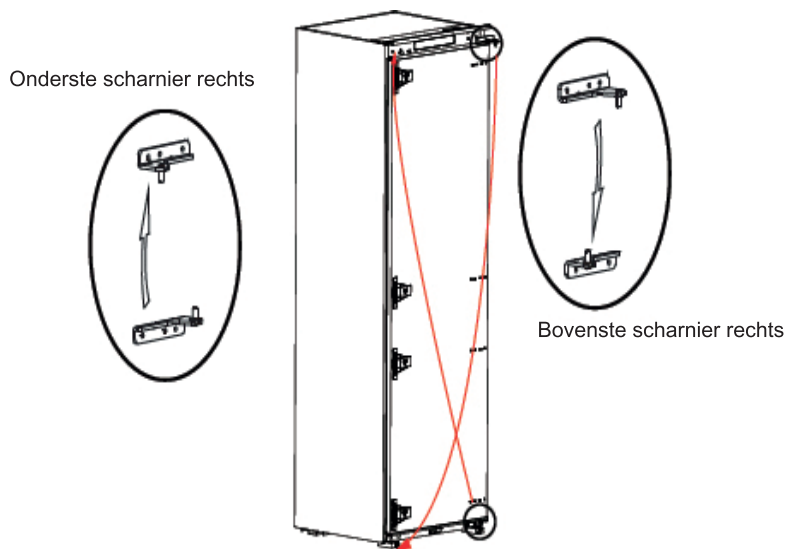

5) Verwijder de twee vaste blokken van de koelkastdeur en draai ze 180° om. Plaats ze dan aan de andere kant van de koelkastdeur.

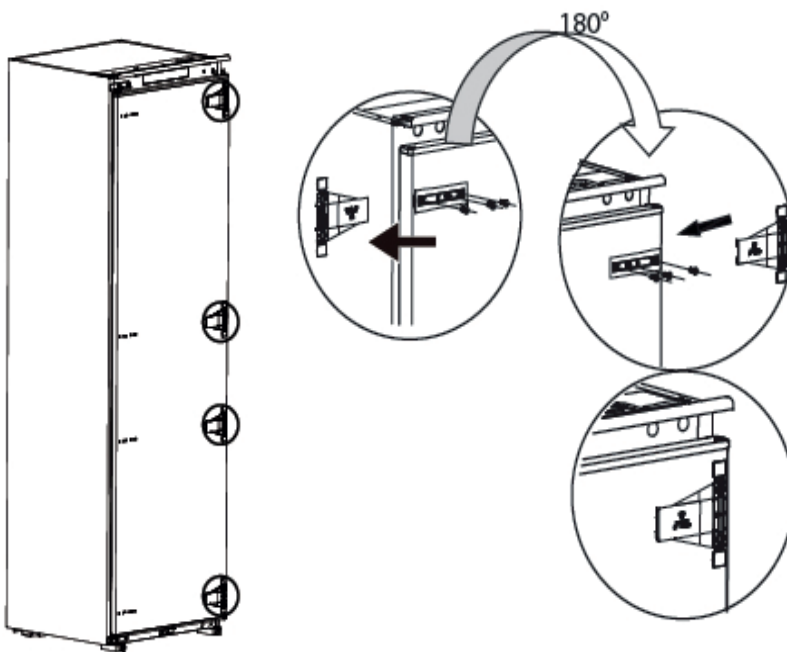

6) De koelkast nadat de stappen uitgevoerd zijn.

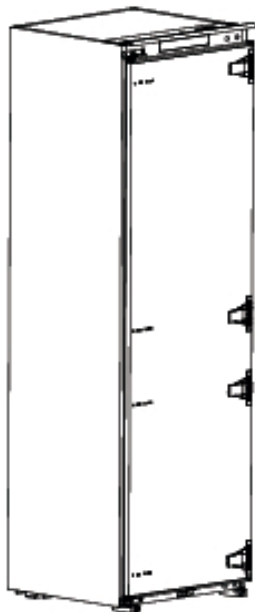

(De bovenstaande afbeelding is uitsluitend bedoeld als referentie. De daadwerkelijke configuratie hangt af van het fysieke product of de verklaring door de verdeler)