

THOMSON

RK200CD

**LECTEUR DE CD PORTABLE AVEC
RADIO ET LECTEUR DE CASSETTES**



MODE D'EMPLOI

**LISEZ COMPLÈTEMENT CE MANUEL D'UTILISATION AVANT
D'UTILISER CET APPAREIL ET CONSERVEZ CE LIVRET POUR
VOUS Y RÉFÉRER ULTÉRIEUREMENT.**



AVERTISSEMENT

APPAREIL À LASER DE CLASSE 1

CLASS 1 LASER PRODUCT
APPAREIL À LASER DE CLASSE 1
PRODUCTO LASER DE CLASE 1

ATTENTION
RAYONNEMENT LASER INVISIBLE SI
L'APPAREIL EST OUVERT ET LES
VERROUILLAGES DÉSACTIVÉS.
ÉVITER TOUTE EXPOSITION AU
RAYON LASER.



Ce produit contient un dispositif laser de faible puissance.

Mise en garde : Ne pas toucher la lentille.

NE PAS JETER LES PILES DANS LE FEU !

PRÉCAUTIONS

Suivre les conseils ci-dessous pour une utilisation sûre et appropriée.

CONSIDÉRATIONS RELATIVES À L'EMPLACEMENT

- Ne pas utiliser l'appareil dans des endroits extrêmement chauds, froids, poussiéreux ou humides.
- Placer l'appareil sur une surface plane et horizontale.
- Ne pas restreindre la circulation d'air autour de l'appareil en le plaçant dans un endroit confiné, en le couvrant avec un tissu, ou en le posant sur un tapis.

CONSIDÉRATIONS RELATIVES À LA SÉCURITÉ

- Lors de la connexion et déconnexion du cordon d'alimentation, tirer sur la prise et non sur le cordon lui-même. Le fait de tirer sur le cordon peut l'endommager et créer un risque.
- Si l'appareil doit rester inutilisé pendant une longue période, débrancher le cordon d'alimentation.

CONSIDÉRATIONS RELATIVES À LA TENSION SECTEUR

- Avant toute utilisation, vérifier que la tension nominale de l'appareil correspond à celle du courant secteur.

CONSIDÉRATIONS RELATIVES À LA CONDENSATION

- Lorsqu'on laisse l'appareil dans une pièce chauffée et humide, des gouttelettes d'eau ou de la condensation peuvent se former à l'intérieur du lecteur de CD.
- En présence de condensation à l'intérieur de l'appareil, il se peut que celui-ci ne fonctionne pas normalement. Le laisser inutilisé pendant 1 heure ou 2 avant de le mettre sous tension, ou augmenter progressivement la température de la pièce et laisser sécher l'appareil avant de l'utiliser.
- Veiller à laisser une distance minimale de 5 cm autour de l'appareil pour une ventilation suffisante.
- Vérifier que la ventilation n'est pas gênée par l'obstruction des orifices de ventilation par des objets tels que journaux, nappes, rideaux, etc.
- Ne pas placer de sources de flammes nues, telles que des chandelles allumées, sur l'appareil.
- Faire attention aux aspects environnementaux de la mise au rebut des piles.
- N'utiliser l'appareil que dans des climats tempérés.
- Ne pas exposer l'appareil à des gouttes ou à des projections de liquide.
- Ne pas placer d'objets remplis de liquide, tels que des vases, sur cet appareil.
- Les piles ne doivent pas être exposées à une source de chaleur excessive telle que le soleil, le feu ou une source de chaleur similaire.
- L'accès à la prise de courant ne doit pas être obstrué ; celle-ci doit rester facilement accessible lors de l'utilisation souhaitée.

En cas de problème, débrancher le cordon d'alimentation secteur et confier la réparation à du personnel qualifié.



L'éclair fléché dans le triangle est un signe d'avertissement qui attire votre attention sur une « tension dangereuse » présente à l'intérieur du produit.

ATTENTION

**RISQUE DE CHOC ÉLECTRIQUE
NE PAS OUVRIR**

ATTENTION : Pour réduire le risque de choc électrique, ne pas retirer le couvercle. L'intérieur de l'appareil ne contient aucune pièce réparable par l'utilisateur. Confier tout entretien à du personnel qualifié.



Le point d'exclamation dans le triangle est un signe d'avertissement qui attire l'attention de l'utilisateur sur des instructions importantes qui accompagnent le produit.

En cas de dysfonctionnement dû à une décharge d'électricité statique, l'appareil doit être réinitialisé en le débranchant de l'alimentation secteur.

**L'ÉTIQUETTE DE MARQUE ET DE CARACTÉRISTIQUES
SE TROUVE À L'ARRIÈRE DE L'APPAREIL.**



EMPLACEMENT DES COMMANDES

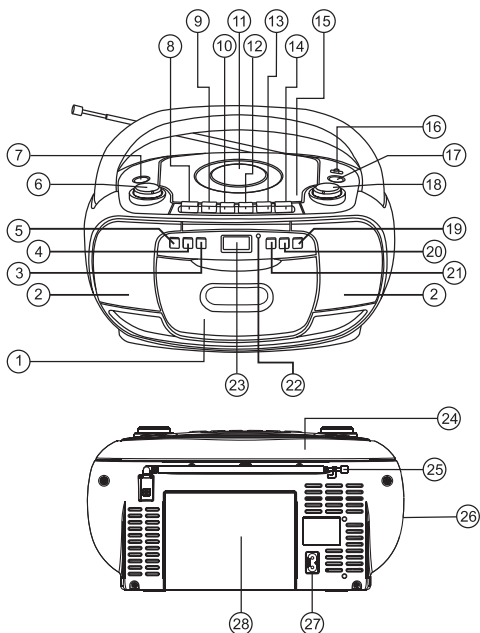

- | | |
|------------------------------------------------------------|---------------------------------------------------------|
| 1. TRAPPE DU LECTEUR DE CASSETTES | 15. BOUTON D'OUVERTURE/ FERMETURE DE LA TRAPPE DE CD |
| 2. HAUT-PARLEUR | 16. BANDE RADIO |
| 3. BOUTON PRÉCÉDENT DU LECTEUR DE CD ◀◀ | 17. BOUTON DE FONCTION |
| 4. BOUTON D'ARRÊT DU LECTEUR DE CD ■ | 18. BOUTON DE RÉGLAGE DES STATIONS |
| 5. BOUTON PROGRAMME CD/RÉGLAGE HORLOGE | 19. BOUTON MODE LECTURE DE CD |
| 6. COMMANDE DE VOLUME | 20. BOUTON SUIVANT DU LECTEUR DE CD ▶▶ |
| 7. BOUTON DE MISE SOUS TENSION ⏻ | 21. BOUTON LECTURE/PAUSE DU LECTEUR DE CD ▶▶ |
| 8. PAUSE DU LECTEUR DE CASSETTES | 22. TÉMOIN DE FM STÉRÉO |
| 9. STOP/ÉJECT. DU LECTEUR DE CASSETTES ■ ▲ | 23. AFFICHAGE LCD |
| 10. AVANCE RAPIDE DU LECTEUR DE CASSETTES ◀◀ | 24. POIGNÉE DE TRANSPORT |
| 11. TRAPPE DE CD | 25. ANTENNE TÉLESCOPIQUE |
| 12. REBOBINAGE/RETOUR RAPIDE DU LECTEUR DE CASSETTES ▶▶ | 26. PRISE JACK D'ENTRÉE AUX |
| 13. LECTURE DU LECTEUR DE CASSETTES ◀ | 27. PRISE C.A. |
| 14. ENREGISTREMENT DU LECTEUR DE CASSETTES ● | 28. COMPARTIMENT DE PILES |

ALIMENTATION ÉLECTRIQUE

UTILISATION DE L'ALIMENTATION ÉLECTRIQUE DOMESTIQUE

Avant toute utilisation, vérifier que la tension nominale de l'appareil correspond à celle du courant secteur.

Remarque : La prise murale sert à débrancher l'appareil. Elle doit rester accessible à tout moment.

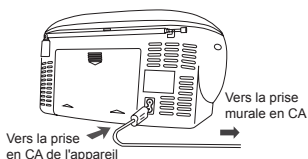

UTILISATION DE PILES

Disconnect the AC power cord
Débrancher le cordon d'alimentation secteur de la prise d'alimentation en CA de l'appareil.

L'alimentation sur piles est automatiquement coupée lorsque le cordon d'alimentation est branché.

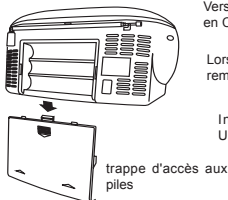

Lorsque le volume diminue, ou si le son est distordu, remplacer toutes les piles par des piles neuves.

Insérer six piles UM-2 (type C)

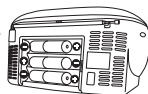

MISE SOUS TENSION / ARRÊT DE L'APPAREIL

Appuyer sur le bouton POWER (Marche) pour activer la fonction audio.

Pour permuter entre les modes audio RADIO, AUX, CASSETTE et CD, appuyer sur le bouton FUNCTION lorsque l'appareil est sous tension.

Le mode audio est affiché.

Éteindre l'appareil en appuyant sur le bouton POWER.

L'affichage indique « OFF », puis l'heure actuelle.

ALIMENTATION ÉLECTRIQUE



FUNCTION



Affichage LCD

ENTRÉE AUX.

Il est possible de brancher une source audio externe (auxiliaire) (par exemple un lecteur de CD portable ou un lecteur MP3) sur cet appareil pour l'écouter sur les haut-parleurs.

- 1) Brancher une extrémité du câble inclus dans la prise AUX IN (Entrée AUX) de l'appareil.
- 2) Brancher l'autre extrémité du câble dans la prise casque ou Sortie ligne de la source externe.
- 3) Appuyer sur le bouton FUNCTION pour sélectionner le mode AUX.

Continuer à utiliser le lecteur de CD ou de MP3 comme d'habitude.

Les plages sélectionnées sont entendues sur les haut-parleurs de cet appareil.

L'appareil s'arrête automatiquement après 4,5 heures d'inutilisation.

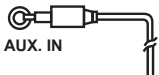

AUX. IN

(Brancher l'autre extrémité sur la source externe telle qu'un lecteur MP3.)



FUNCTION



Affichage LCD

RÉGLAGE DU SON

POUR RÉGLER LE VOLUME



RÉGLAGE DE L'HORLOGE

En mode veille, le panneau LCD affiche l'horloge.

1. Maintenir enfoncé le bouton PROGRAM / CLOCK-ADJ (Programme/Réglage horloge).
2. Pour sélectionner l'affichage sur 12 heures ou 24 heures, appuyer sur le bouton NEXT ►► ou BACK ◄◄.
3. Appuyer sur le bouton PROGRAM / CLOCK-ADJ. (Programme/Réglage horloge), les chiffres des heures se mettent à clignoter.
4. Pour régler les chiffres des heures, appuyer sur le bouton NEXT ►► ou BACK ◄◄.
5. Appuyer sur le bouton PROGRAM / CLOCK-ADJ (Programme/Réglage horloge), les chiffres des minutes se mettent à clignoter.
6. Pour régler les chiffres des minutes, appuyer sur le bouton NEXT ►► ou BACK ◄◄.
7. Appuyer de nouveau sur le bouton PROGRAM / CLOCK-ADJ (Programme/Réglage horloge), le panneau LCD affiche l'heure exacte.



ÉCOUTE DE LA RADIO

1. Éteindre l'appareil en appuyant sur le bouton POWER

ALIMENTATION
ÉLECTRIQUE



2. Appuyer sur le bouton FUNCTION pour sélectionner le mode RADIO.

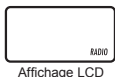

FUNCTION



3. Sélecteur de bande radio.

BANDE RADIO

AM FM



POUR UNE MEILLEURE RÉCEPTION

FM



AM

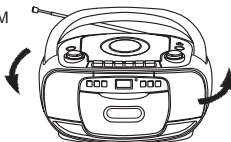

4. Rechercher une station.

RECHERCHE DES STATIONS

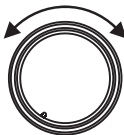

5. Régler le volume sonore.

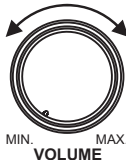



APRÈS L'ÉCOUTE

Éteindre l'appareil en appuyant sur le bouton POWER (Marche).

LECTURE D'UN COMPACT DISC

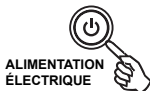
1. Éteindre l'appareil en appuyant sur le bouton POWER .



2. Appuyer sur le bouton FUNCTION pour sélectionner le mode CD. Le symbole «  » clignote pendant l'attente du CD.

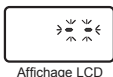

3. Ouvrir la trappe de CD en appuyant sur le bouton Open/Close CD.



4. Insérer un CD, étiquette vers le haut.



5. Fermer la trappe de CD. Le CD commence à tourner et le nombre total de pistes s'affiche sur le panneau LCD.



6. Appuyer sur le bouton PLAY/PAUSE . Le numéro de piste « 01 » et le symbole «  » sont affichés.



POUR INTERROMPRE LA LECTURE

Appuyer sur le bouton PLAY/PAUSE  et le symbole «  » se met à clignoter. Appuyer de nouveau sur le bouton pour reprendre la lecture.







POUR ARRÊTER LA LECTURE



Appuyer sur le bouton STOP  ; le panneau LCD affiche le nombre total de pistes du CD.



POUR SAUTER AU DÉBUT D'UNE PISTE

- Appuyer sur l'un des boutons de saut  ou  en fonction de la direction du saut voulu.
- La lecture reprend depuis la piste sélectionnée.
- Lorsque le bouton  est enfoncé une fois pendant la lecture, celle-ci reprend depuis la piste précédente.
- Lorsque le bouton  est enfoncé une fois pendant la lecture, c'est la piste suivante qui est lue.

RECHERCHE D'UN PASSAGE À L'INTÉRIEUR D'UNE PISTE

- Maintenir enfoncé le bouton  ou  pendant la lecture et le relâcher dès que le passage voulu est atteint. La lecture normale du CD reprend depuis ce point.

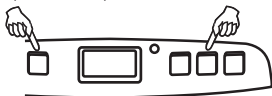

L'appareil s'éteint automatiquement après 30 mn d'inutilisation (en mode Arrêt/trappe de CD ouverte).

RÉPÉTER, TOUT RÉPÉTER ET MÉLANGER LA LECTURE

Appuyer sur le bouton PLAY MODE pendant l'arrêt. L'appareil lit une seule piste du CD en boucle, toutes les pistes en boucle ou de manière aléatoire.

MODE DE LECTURE



POUR LA LECTURE NORMALE D'UN CD

Ordre des différents modes de lecture REPEAT >> REPEAT ALL >> MIX >> CLEAR.

En mode Repeat 1, le panneau LCD affiche



En mode Mix, le panneau LCD affiche



Affichage LCD

En mode Repeat 2, le panneau LCD affiche



Affichage LCD

LECTURE PROGRAMMÉE

La lecture programmée permet de jouer les pistes d'un disque dans l'ordre souhaité. Il est possible de programmer jusqu'à 20 pistes.

1. Appuyer sur le bouton PROGRAM.
2. Pour sélectionner le numéro de piste voulu, appuyer sur les boutons NEXT et BACK.
3. Appuyer de nouveau sur le bouton PROGRAM pour mémoriser la piste.
4. Répéter les étapes 2 et 3 jusqu'à ce que toutes les pistes voulues aient été programmées.
5. Appuyer sur le bouton PLAY/PAUSE (Lecture/Pause) pour lancer la lecture programmée. L'écran LCD affiche ►, PROG et le numéro de piste.
6. Appuyer une fois sur le bouton STOP pour arrêter la lecture programmée.

7. Appuyer sur le bouton PLAY/PAUSE (Lecture/Pause) pour reprendre la lecture programmée.
8. Ouvrir la trappe de CD, éteindre le lecteur de CD ou appuyer deux fois sur le bouton STOP pour effacer la mémoire programmée.

Remarque : La programmation ne peut être réalisée qu'en mode Arrêt.



" PROGRAMME "



Affichage LCD

Remarque sur les disques CD-R/RW

- En raison de la définition/de la production dans un format non standardisé des CD-R/RW, la qualité et les performances de lecture ne sont pas garanties.
- Le fabricant n'assume aucune responsabilité pour la possibilité de lire les CD-R/RW en raison des conditions d'enregistrement telles que les performances du PC, le logiciel de gravure, les possibilités du support, etc.
- Ne fixer aucune vignette ni étiquette sur les faces du CD-R/RW. Cela pourrait provoquer un dysfonctionnement.
- Il est recommandé de n'enregistrer que des fichiers audio sur les CD-R/RW pour en faciliter la lecture.

LECTURE D'UNE CASSETTE

1. Éteindre l'appareil en appuyant sur le bouton POWER .



ALIMENTATION
ÉLECTRIQUE

2. Appuyer sur le bouton FUNCTION pour sélectionner le mode CASSETTE.



Affichage LCD



FONCTION

3. Insérer la cassette.



4. Appuyer sur le bouton PLAY .



LECTURE

POUR ARRÊTER LA LECTURE

Pour interrompre la lecture, appuyer sur le bouton STOP / EJECT.

AVANCE OU LE RECUIL RAPIDE

Appuyer sur le bouton REWIND or F.FWD. Appuyer sur le bouton STOP/EJECT pour arrêter le bobinage.

POUR INTERROMPRE LA LECTURE

Pour reprendre la lecture, appuyer de nouveau sur le bouton PAUSE.

ENREGISTREMENT

N'UTILISER QU'UNE CASSETTE NORMALE (TYPE I) POUR L'ENREGISTREMENT.

1. Insérer la cassette.



2. Appuyer sur le bouton PAUSE .



3. Appuyer sur le bouton RECORD .

ENREGISTREMENT



4. Préparer la source à enregistrer et lancer la lecture. Appuyer sur le bouton FUNCTION pour sélectionner le mode CD ou RADIO.

Enregistrement d'un CD



LANCER LA LECTURE DU CD

Enregistrement de la radio



RÉGLER LA RADIO SUR UNE STATION

5. Appuyer sur le bouton PAUSE .



POUR ARRÊTER L'ENREGISTREMENT

Appuyer sur le bouton STOP / EJECT.

POUR ARRÊTER L'ENREGISTREMENT

Appuyer sur le bouton PAUSE. Pour reprendre l'enregistrement, appuyer de nouveau sur le bouton PAUSE..

POUR EFFACER UNE CASSETTE ENREGISTRÉE

1. Appuyer sur le bouton FUNCTION pour sélectionner le mode CASSETTE.
2. Insérer une cassette, face à effacer vers vous.
3. Appuyer sur le bouton RECORD (Enregistrement) pour commencer l'effacement.

ENTRETIEN

NETTOYAGE DES CD

Si le son du CD saute ou si la lecture est impossible, il est possible que le disque ait besoin d'être nettoyé. Avant la lecture, essayer le disque du centre vers l'extérieur avec un chiffon de nettoyage. Après la lecture, ranger le disque dans son boîtier.



NETTOYAGE DE L'APPAREIL

Ne pas utiliser de produits chimiques volatils sur cet appareil. Le nettoyer en frottant légèrement avec un chiffon doux.

REMARQUE IMPORTANTE

En cas d'affichage anormal ou de problème de fonctionnement, débrancher le cordon d'alimentation secteur et retirer les piles. Attendre au moins 5 secondes, puis rebrancher le cordon d'alimentation secteur ou réinstaller les piles.

NETTOYAGE DE LA LENTILLE DU LECTEUR DE CD

Si la lentille du lecteur de CD est poussiéreuse, la nettoyer avec une brosse soufflante. Souffler plusieurs fois sur la lentille et éliminer la poussière avec la brosse. Les empreintes de doigts peuvent être éliminées avec un coton-tige humecté avec de l'alcool.

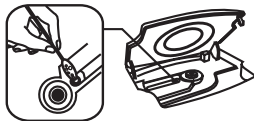

AVERTISSEMENT

Si la trappe du CD était ouverte avant la fin de la lecture du CD, on pourrait entendre un bruit de coincement. Le problème serait résolu en fermant la trappe du CD.

CARACTÉRISTIQUES TECHNIQUES

PARTIE LECTEUR DE CASSETTES

| | |
|-------------------------------------|-------------------------------------|
| Format des pistes : | 2 pistes stéréo |
| Système d'enregistrement : | Polarisation en courant alternatif |
| Système d'effacement : | Effacement magnétique 6 pôles |
| Vitesse de défilement : | 4,75 cm/s. |
| Durée en avance et retour rapides : | 170 s. (cassette F-60) |
| Réponse en fréquence ; | 125 Hz - 8000 Hz (cassette normale) |

PARTIE LECTEUR DE CD

| | |
|-------------------------------|---------------------------------|
| Canaux : | 2 canaux |
| Rapport S/B : | 60 dB |
| Distorsion et pleurage : | non détectables |
| Fréquence d'échantillonnage : | 44,1 kHz 8 x suréchantillonnage |
| Quantification : | Convertisseur 1 bit NA |
| Source optique de lecture : | Laser semiconducteur |
| Longueur d'onde de lecture : | 790 nm |

PARTIE RADIO

| | |
|------------------------|--------------------------------------------------|
| Plages de fréquences : | FM 87.5 - 108 MHz AM 522 - 1620 kHz |
| Antennes : | Antenne AM ferrite intégrée Antenne FM rigide |

CARACTÉRISTIQUES GÉNÉRALES

| | |
|------------------------------------|---------------------------------------------------------|
| Puissance de sortie : | 1.2 W + 1.2 W (RMS) |
| Consommation électrique : | 9.5 W |
| Prise Jack d'entrée AUX (AUX IN) : | 3.5 MM |
| Haut-parleurs : | 3 po. 8 OHMS |
| Source d'alimentation électrique : | CA : 230V ~ 50Hz CC : 9 V (6 x 1,5V LR14/ « C »/UM2) |

| | |
|--------------|----------------------------|
| Dimensions : | 294(l) x 206(P) x 153(H)mm |
| Poids : | 1,72 Kg |

En raison des améliorations permanentes apportées au produit, ses caractéristiques et sa conception sont susceptibles de modifications sans préavis.

Où placer l'appareil :

Les meubles d'aujourd'hui sont revêtus d'une grande diversité de laques et de revêtements synthétiques qui sont traités avec de nombreux produits de nettoyage différents. C'est pourquoi il est impossible d'exclure totalement le risque que certaines de ces substances contiennent des composants susceptibles de réagir avec les pieds en caoutchouc de l'appareil et de les amollir. Les pieds en caoutchouc de l'appareil peuvent décolorer la surface des meubles. Si nécessaire, placer l'appareil sur une surface non glissante.

Remarque: Afin d'économiser de l'énergie, lorsqu'il n'émet pas de son pendant un certain temps, l'appareil sera mis automatiquement en veille. Pour le remettre en fonctionnement, il vous suffit de sélectionner une fonction à nouveau.

Ne pas jeter les appareils électriques et électroniques avec les déchets habituels.

- Les apporter à un point de collecte.
- Certaines pièces contenues dans ces appareils peuvent être dangereuses pour la santé et pour l'environnement.



Fabriqué par BIGBEN INTERACTIVE SA
396, Rue de la Voyette
CRT2 – FRETIN
CS 90414
59814 LESQUIN Cedex - France
www.bigben.eu
Fabriqué en Chine



bigben

Fabricant : Bigben Interactive FRANCE

396, Rue de la Voyette, C.R.T. 2 Fretin,
CS 90414 - 59814 LESQUIN Cedex

Bigben Interactive DEUTSCHLAND GmbH

Walter Gropius Str. 28, 50126 Bergheim, Deutschland

Bigben Interactive BELGIUM

Avenue Ernest Solvay, 1480 Tubize, Belgique

Bigben Interactive NEDERLAND b.v.

Franciscusweg 249-3B, 1216 SG Hilversum, Nederland

Bigben Interactive SPAIN S.L.

C/ Musgo 5, 2ª planta, 28023 Madrid, Spain

Bigben Interactive ITALIA s.r.l

Corso Sempione 221, 20025 Legnano - MI, Italia

FABRIQUÉ EN CHINE / MADE IN CHINA

HOTLINE

FRANCE, du lundi au vendredi (sauf jours fériés) :
9h00-19h00 ou support@thomsonaudiovideo.eu

N°Cristal 09 69 32 59 62

APPEL NON SURTAXE

DEUTSCHLAND, Montag bis Sonntag von 8:00 bis 24:00 Uhr
09001-84 30 44* (0,49€/Min. aus dem deutschen Festnetz, Anrufe aus allen

Mobilfunknetzen nicht möglich) oder support@bigben-interactive.de

*Minderjährige müssen vorher einen Erziehungsberechtigten um Erlaubnis fragen.

BELGIQUE / NEDERLAND, klantenservice@bigben-interactive.nl
customerservice@bigben-interactive.be

ESPAÑA, sat@bigbeninteractive.es

ITALIA, support@bigbeninteractive.it

www.bigben.eu

THOMSON est une marque déposée de TECHNICOLOR SA ou de ses filiales sous licence pour Bigben Interactive.

FR-10

THOMSON

RK200CD

PORTABLE CD PLAYER
WITH RADIO & CASSETTE PLAYER



OPERATING INSTRUCTIONS

PLEASE READ THIS USER MANUAL COMPLETELY BEFORE
OPERATING THIS UNIT AND RETAIN THIS BOOKLET FOR
FUTURE REFERENCE.



WARNING

CLASS 1 LASER PRODUCT

CLASS 1 LASER PRODUCT
APPAREIL À LASER DE CLASSE 1
PRODUCTO LASER DE CLASE 1

CAUTION
INVISIBLE LASER RADIATION
WHEN OPEN AND INTERLOCKS
DEFEATED.
AVOID EXPOSURE TO BEAM



This product contains a low power laser device.

Warning: Do not touch the lens.

DO NOT THROW BATTERIES IN FIRE !

PRECAUTIONS

Follow the advice below for safe and appropriate operations.

ON PLACEMENT

- Do not use the unit in places which are extremely hot, cold, dusty, or humid.
- Place the unit on a flat and even surface.
- Do not restrict the air flow of the unit by placing it in a place with poor air flow, by covering it with a cloth, or by placing it on a carpet.

ON SAFETY

- When connecting and disconnecting the AC cord, grip the plug and not the cord itself. Pulling the cord may damage it and create hazard.
- When you are not going to use the unit for a long period of time, disconnect the AC power cord.

ON AC VOLTAGE

- Before use, check that the rated voltage of your unit matches your local voltage.

ON CONDENSATION

- When left in a heated room where it is warm and damp, water droplets or condensation may form inside the CD player.
- When there is condensation inside the unit, the unit may not function normally.
- Let it stand for 1 to 2 hours before turning the power on, or gradually heat the room up and dry the unit before use.
- Ensure a minimum distance of 5 cm around the apparatus for sufficient ventilation.
- Ensure that the ventilation is not impeded by covering the ventilation openings with items, such as newspapers, table-cloths, curtains, etc..
- Do not place naked flame sources, such as lighted candles on the apparatus.
- Take attention to the environmental aspects of battery disposal.
- Use the apparatus only in moderate climates.
- Do not expose the apparatus to dripping or splashing.
- Do not place objects filled with liquids, such as vases, on the apparatus.
- Battery shall not be exposed to excessive heat such as sunshine, fire or the like.
- The mains plug of apparatus should not be obstructed OR should be easily accessed during intended use.

Should any trouble occur, disconnect the AC power cord and refer servicing to qualified personnel.



The lightning flash with arrowhead symbol within the triangle is a warning sign alerting the user of "dangerous voltage" inside the unit.

CAUTION

**RISK OF ELECTRIC SHOCK
DO NOT OPEN**

ATTENTION : To reduce the risk of electric shock, do not remove the cover. There are no user serviceable parts inside the unit. Refer all servicing to qualified personnel.



The exclamation point within the triangle is a warning sign alerting the user of important instructions accompanying the product.

In case of malfunction due to electrostatic discharge the apparatus has to be reset by disconnecting it from mains supply.
THE MARKING INFORMATION IS LOCATED AT THE BACK OF APPARATUS.



LOCATION OF CONTROLS

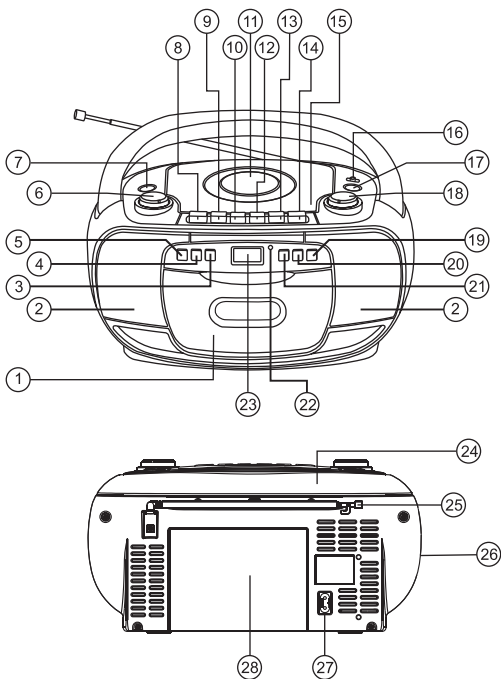

- | | |
|-----------------------------------|------------------------------|
| 1. CASSETTE DOOR | 15. OPEN/CLOSE CD BUTTON |
| 2. SPEAKER | 16. BAND SWITCH |
| 3. CD BACK BUTTON ◀◀ | 17. FUNCTION BUTTON |
| 4. CD STOP BUTTON ■ | 18. TUNING CONTROL |
| 5. CD PROGRAM / CLOCK-ADJ. BUTTON | 19. CD PLAY MODE BUTTON |
| 6. VOLUME CONTROL | 20. CD NEXT BUTTON ▶▶ |
| 7. POWER BUTTON ⏻ | 21. CD PLAY / PAUSE BUTTON ▶ |
| 8. CASSETTE PAUSE | 22. FM STEREO INDICATOR |
| 9. CASSETTE STOP/EJECT ■ ▲ | 23. LCD DISPLAY |
| 10. CASSETTE F.FWD ◀◀ | 24. CARRYING HANDLE |
| 11. CD DOOR | 25. TELESCOPIC ANTENNA |
| 12. CASSETTE REWIND ▶▶ | 26. AUX. IN JACK |
| 13. CASSETTE PLAY ◀ | 27. AC SOCKET |
| 14. CASSETTE RECORD ● | 28. BATTERY COMPARTMENT |

POWER SUPPLY

USING HOUSE CURRENT

Before use, check that the rated voltage of your unit matches your local voltage.

Note: Plug is used as the disconnect device.
The disconnect device shall remain readily operable.

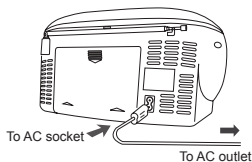

USING BATTERIES

Disconnect the AC power cord from the AC inlet of the unit.
Battery power is cut automatically by the cord while it is connected.

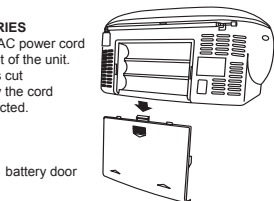

When the volume decrease, or the sound distorts, replace all of the batteries with new ones.

Insert six UM-2
(size C) batteries.

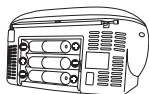

TURN ON / OFF THE SYSTEM

Press the POWER button to turn the audio on.
To change the audio mode between RADIO, AUX, TAPE and CD, press the FUNCTION button while the power is on.
The audio mode is displayed.
Turn off the unit by pressing the POWER button.
"OFF" word will be shown on the display and then resume the current time.

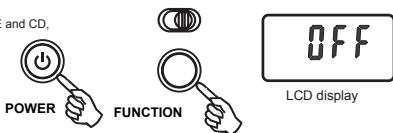

AUX. IN

An external (auxiliary) audio source (i.e., personal CD player or MP3 player) can be connected to this unit and heard through the speakers.

- 1) Plug one end of cable into the AUX IN socket on the unit.
- 2) Plug the other end of the cable into the Headphone or Line Out socket of the external source.
- 3) Press the FUNCTION button to select AUX.

Continue to operate CD or MP3 player as usual.
Selections will be heard through the unit's speakers.

Unit will be automatically off after 4.5 hours without further operation.

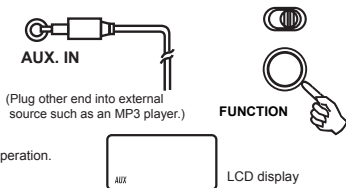

ADJUSTING THE SOUND

TO ADJUST THE VOLUME



CLOCK ADJUSTMENT

The clock is displayed on LCD display at standby mode.

1. Press and hold the PROGRAM / CLOCK-ADJ. button.
2. Press the ►►► NEXT or ◀◀◀ BACK to select 12 hours or 24 hours display.
3. Press the PROGRAM / CLOCK-ADJ. button, the hour digit flash.
4. Press the ►►► NEXT or ◀◀◀ BACK to adjust hour digit.
5. Press the PROGRAM / CLOCK-ADJ. button, the minute digit flash.
6. Press the ►►► NEXT or ◀◀◀ BACK to adjust minute digit.
7. Press the PROGRAM / CLOCK-ADJ. button again, the correct time is shown on display.

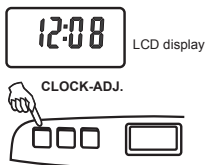

LISTENING TO THE RADIO

1. Turn on the unit by pressing the POWER  button.



2. Press the FUNCTION button to select RADIO .

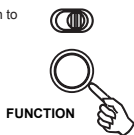
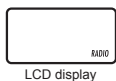

3. Select a band.

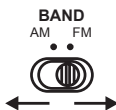

FOR BETTER RECEPTION

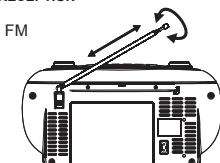

4. Tune in to a station.

TUNING

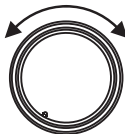

5. Adjust the sound.

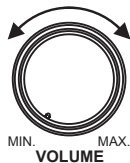

AFTER LISTENING

Turn off the unit by pressing the POWER button.

COMPACT DISC PLAYBACK

1. Turn on the unit by pressing the POWER  button.



POWER

2. Press the FUNCTION button to select CD. The symbol " _ " flashes for searching CD disc.



LCD display

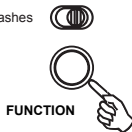

FUNCTION

3. Open the CD door by pushing Open / Close CD button.



4. Insert a disc with the label side facing up.

5. Close the CD door.
The disc will rotate and the total tracks of the disc will show on the display.



6. Press the PLAY/PAUSE  button. Track number "01" & the symbol "▶" will be shown.



LCD display



TO INTERRUPT PLAYBACK

Press the Play/ Pause  button and the symbol "▶" will be flashed. Press the button again to resume playback.



LCD display







TO STOP PLAYBACK



Press the STOP  button and the display shows the total tracks of the disc.



TO SKIP TO THE BEGINNING OF A TRACK

- Press either one of the   skip buttons according to the desired skip direction.
- Play/back resumes from the selected track.
- When the  button is pressed once during play, the previous track starts again.
- When the  button is pressed once during play, the next track plays.

SEARCHING FOR A PASSAGE WITHIN A TRACK

- Keep the  or  button pressed during playback, and release the button as soon as you recognise the desired passage. Then normal CD playback will resume from this point.



Unit will be automatically off after 30mins without further operation (in stop mode / CD door open).

REPEAT , REPEAT ALL AND MIX PLAYBACK

Press PLAY MODE button during stop mode. CD plays with a single track repeat, all tracks repeat or randomly.

PLAY MODE

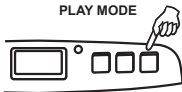

FOR NORMAL COMPACT DISC PLAYBACK

Mode sequence REPEAT >> REPEAT ALL >> MIX >> CLEAR.

During Repeat 1 mode, display shows



During Mix mode, display shows



LCD display

During Repeat 2 mode, display shows



LCD display

PROGRAMMED PLAYBACK

PROGRAMMED PLAYBACK

Programmed playback enables tracks on a disc to be played in the desired order. Up to 20 tracks can be programmed.

1. Press the " PROGRAM " button.
2. Press the " NEXT " and " BACK " buttons to select the desired track number.
3. Press the " PROGRAM " button again to memorize the track.
4. Repeat steps 2 and 3 until all desired tracks are programmed.
5. Press the " PLAY/PAUSE " button to start. " ► ", " PROG " & track number are shown on the CD display.
6. Press the " STOP " button once to stop programmed playback.

7. Press the " PLAY/PAUSE " button to resume programmed playback.
8. Open the CD door, turn off the CD player or press the " STOP " button twice to clear the programmed memory.

Note : Programming can only be made when the player is in stop mode.



LCD display

Note on CD-R/RW discs

- Because of non-standardized format definition/ production of CD-R/RW, playback quality and performance are not guaranteed.
- Manufacturer is not responsible for the playability of CD-R/RW due to recording conditions, such as PC performance, writing software, media ability, etc.
- Do not attach a seal or label to either side of the CD-R/RW disc. It may cause a malfunction.
- It is recommended to record only audio files on CD-R/RW discs for easy reading.

TAPE PLAYBACK

1. Turn on the unit by pressing the POWER button.



POWER

2. Press the FUNCTION button to select TAPE.



FUNCTION



LCD display

3. Insert the cassette.



4. Press the ◀ PLAY button.



PLAY

TO STOP PLAYBACK

Press the STOP / EJECT button.

TO INTERRUPT PLAYBACK

Press the PAUSE button.

To resume play, press the PAUSE button again.

TO FAST WIND

Press the REWIND or F.FWD button. Press the STOP / EJECT button to stop winding at the desired position.

RECORDING

USE ONLY NORMAL (TYPE I) TAPE FOR RECORDING.

1. Insert the cassette tape.



2. Press the PAUSE  button.



3. Press the RECORD  button.



4. Prepare to play the source to be recorded and play it. Press the FUNCTION button to select CD or RADIO.

Recording from a CD



PLAY THE CD

Recording from the radio



TUNE INTO A STATION

5. Press the PAUSE  button.



TO STOP RECORDING

Press the STOP / EJECT button.

TO INTERRUPT RECORDING

Press the PAUSE button.

To resume recording, press the PAUSE button again.

TO ERASE A RECORDED TAPE

1. Press the FUNCTION button to select TAPE.
2. Insert a tape with the side you want to erase facing you.
3. Press the RECORD button to start erasing.

MAINTENANCE

CLEANING CD

If the CD skips or will not play, the disc may need cleaning. Before playing, wipe the disc from the centre out with a cleaning cloth. After playing, store the disc in its case.



CLEANING THE UNIT

Do not use volatile chemicals on this unit. Clean by lightly wiping with a soft cloth.

IMPORTANT NOTE

If an abnormal display indication or an operating problem occurs, disconnect the AC power cord and remove the batteries. Wait at least 5 seconds, then reconnect the AC power cord or reinstall the batteries.

CLEANING THE CD LENS

If the CD lens is dusty, clean it with a brush-blower. Blow several times on the lens and remove the dust with the brush. Finger prints may be removed with a cotton swab moistened with alcohol.

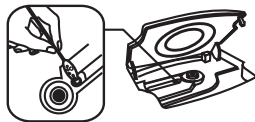

WARNING

Should the CD door be opened before the reading of the CD is completed, a jamming noise may occur. This is resolved by closing the CD door.

SPECIFICATIONS

CASSETTE SECTION

| | |
|---------------------|--------------------------------|
| Track format: | 2 track stereo |
| Recording system: | AC bias |
| Erasing system: | Magnetic erase 6 poles |
| Tape speed: | 4.75 cm / sec. |
| F.F. & REW time: | 170 sec. (F-60 tapes) |
| Frequency response: | 125 Hz - 8000 Hz (Normal tape) |

CD SECTION

| | |
|-----------------------|----------------------------|
| Channels: | 2 channels |
| S / N ratio: | 60 dB |
| Wow & Flutter: | undetectable |
| Sampling frequency: | 44.1 kHz 8 x over sampling |
| Quantization: | 1 bit DA converter |
| Pick up light source: | Semi - conductor laser |
| Pick up wave length: | 790 nm |

RADIO SECTION

| | |
|----------------|---------------------------------------------|
| Tuning ranges: | FM 87.5 - 108 MHz AM 522 - 1620 kHz |
| Antennas: | AM Built - in ferrite bar FM Rod antenna |

GENERAL

| | |
|--------------------|--------------------------------------------------------|
| Output power: | 1.2 W + 1.2 W (RMS) |
| Power consumption: | 9.5 W |
| Aux In Jack: | 3.5 MM |
| Speaker: | 3 " 8 OHM |
| Power source: | AC : 230V ~ 50Hz DC : 9V (6 x 1.5V LR14/ "C"/UM2) |
| Dimensions: | 294(L) x 206(D) x 153(H)mm |
| Weight | 1.72 KGS |

Due to continuing improvement, the features and the design are subject to change without notice.

Where to place the item :

Today's furniture is coated with a wide variety of lacquers and synthetic-coatings that are treated with an extensive range of cleaning products. Therefore, the possibility that some of these substances contain components that react adversely to the rubber feet of the item and soften them, cannot be completely excluded. The rubber feet of the appliance can cause discoloring to furniture surfaces. If necessary, place the appliance on a non-slide surface.

Remark: In order to save energy when the unit has no sound output for a while, the unit will be switched to stand-by automatically. It can be switched ON by using the function selector again.

Don't discard the electrical and electronic appliances in the regular waste disposal.

- Take them to a collection point.
- Some components in these appliances may be hazardous to health and the environment.



Manufactured by BIGBEN INTERACTIVE SA
396, Rue de la Voyette
CRT2 - FRETIN
CS 90414
59814 LESQUIN Cedex - France
www.bigben.eu
MADE IN CHINA



bigben

Fabricant : Bigben Interactive FRANCE

396, Rue de la Voyette, C.R.T. 2 Fretin,
CS 90414 - 59814 LESQUIN Cedex

Bigben Interactive DEUTSCHLAND GmbH

Walter Gropius Str. 28, 50126 Bergheim, Deutschland

Bigben Interactive BELGIUM

Avenue Ernest Solvay, 1480 Tubize, Belgique

Bigben Interactive NEDERLAND b.v.

Franciscusweg 249-3B, 1216 SG Hilversum, Nederland

Bigben Interactive SPAIN S.L.

C/ Musgo 5, 2ª planta, 28023 Madrid, Spain

Bigben Interactive ITALIA s.r.l

Corso Sempione 221, 20025 Legnano - MI, Italia

FABRIQUÉ EN CHINE / MADE IN CHINA

HOTLINE

FRANCE, du lundi au vendredi (sauf jours fériés) :
9h00-19h00 ou support@thomsonaudiovideo.eu

N°Cristal 09 69 32 59 62

APPEL NON SURTAXE

DEUTSCHLAND, Montag bis Sonntag von 8:00 bis 24:00 Uhr
09001-84 30 44* (0,49€/Min. aus dem deutschen Festnetz, Anrufe aus allen

Mobilfunknetzen nicht möglich) oder support@bigben-interactive.de

*Minderjährige müssen vorher einen Erziehungsberechtigten um Erlaubnis fragen.

BELGIQUE / NEDERLAND, klantenservice@bigben-interactive.nl
customerservice@bigben-interactive.be

ESPAÑA, sat@bigbeninteractive.es

ITALIA, support@bigbeninteractive.it

www.bigben.eu

THOMSON is a trademark of TECHNICOLOR SA or its affiliates used under license to Bigben Interactive.

GB-10

THOMSON

RK200CD

**REPRODUCTOR PORTÁTIL DE CD Y
CASSETES CON RADIO**



INSTRUCCIONES DE FUNCIONAMIENTO

LE ROGAMOS QUE LEA ÍNTEGRAMENTE EL PRESENTE MANUAL DEL USUARIO ANTES DE UTILIZAR EL EQUIPO Y QUE LO CONSERVE PARA PODER CONSULTARLO EN EL FUTURO.



ADVERTENCIA

PRODUCTO LÁSER DE CLASE 1

CLASS 1 LASER PRODUCT
APPAREIL À LASER DE CLASSE 1
PRODUCTO LÁSER DE CLASE 1

PRECAUCIÓN
CUANDO SE ABRE LA TAPA Y SE ROMPEN
LOS SEGUROS DE LA MISMA, SE PRODUCE
RADIACIÓN LÁSER INVISIBLE.
EVITE LA EXPOSICIÓN A LA FUENTE DE
LÁSER



Este producto incluye un dispositivo láser de baja potencia.

Advertencia: no toque la lente.
NO TIRE LAS PILAS AL FUEGO!

PRECAUCIONES

Para un funcionamiento seguro y apropiado, siga los consejos que se indican a continuación.

UBICACIÓN

- No utilice el equipo en lugares con excesivo calor, frío, polvo o humedad.
- Coloque el equipo sobre una superficie lisa y horizontal.
- No coloque el equipo en un lugar que no permita fluir bien el aire, ni lo cubra con una tela, ni lo coloque sobre una alfombra, ya que esto limitaría el flujo de aire del equipo.

SEGURIDAD

- Cuando conecte o desconecte el cable de la corriente, hágalo sujetando el enchufe y no el cable. Si se tira del cable, éste se puede dañar o generar una situación de riesgo.
- Cuando no vaya a utilizar el equipo durante mucho tiempo, desconecte el cable de alimentación.

VOLTAJE DE ALIMENTACIÓN (CA)

- Antes de utilizar el equipo, compruebe que su voltaje coincida con la tensión de la red local.

CONDENSACIÓN

- Cuando se deja el equipo en una habitación cálida y húmeda, es posible que se formen gotitas de agua o condensación en el interior del reproductor de CD.
- En caso de que se produzca condensación en el interior del equipo, éste podría no funcionar bien.
- Téngalo sin encender durante 1 ó 2 horas o caliente gradualmente la habitación y seque el equipo antes de usarlo.
- Asegúrese de dejar una distancia mínima de 5 cm alrededor del aparato para que esté suficientemente ventilado.
- Compruebe que los orificios de ventilación no queden obstruidos con ningún objeto, como periódicos, manteles, cortinas, etc.
- No coloque sobre el aparato ninguna llama viva, como, por ejemplo, velas encendidas.
- Tenga en cuenta los factores medioambientales a la hora de desechar las pilas.
- Utilice el aparato únicamente en climas moderados.
- El equipo no se debe ver expuesto a ningún tipo de goteo o salpicadura,
- ni deberá colocarse sobre él ningún objeto que contenga líquido (como jarrones).
- Las pilas no se han de ver expuestas a un calor excesivo, como el generado por el sol, el fuego o similares.
- El enchufe del equipo no debe obstruirse y tendrá que permanecer fácilmente accesible durante el uso.

Si se produjera algún problema, desconecte el cable de alimentación y acuda a personal técnico cualificado.



El triángulo con un símbolo de rayo con punta de flecha en su interior avisa al usuario de «peligro - alto voltaje» en el interior del equipo.

PRECAUCIÓN

RIESGO DE DESCARGA
ELÉCTRICA NO ABRIR

ATENCIÓN: Para reducir el riesgo de descarga eléctrica, no retire la cubierta. En el interior del equipo no hay piezas que el usuario pueda reparar. Para cualquier reparación, acuda siempre a personal cualificado.



El triángulo con un signo de exclamación sirve de advertencia para indicar al usuario que el artículo va acompañado de instrucciones importantes.

En caso de malfuncionamiento debido a descarga electrostática, habrá que reiniciar el aparato desconectándolo de la red eléctrica.

LA INFORMACIÓN DE MARCADO DEL EQUIPO SE ENCUENTRA EN LA PARTE TRASERA DEL MISMO.



UBICACIÓN DE LOS CONTROLES

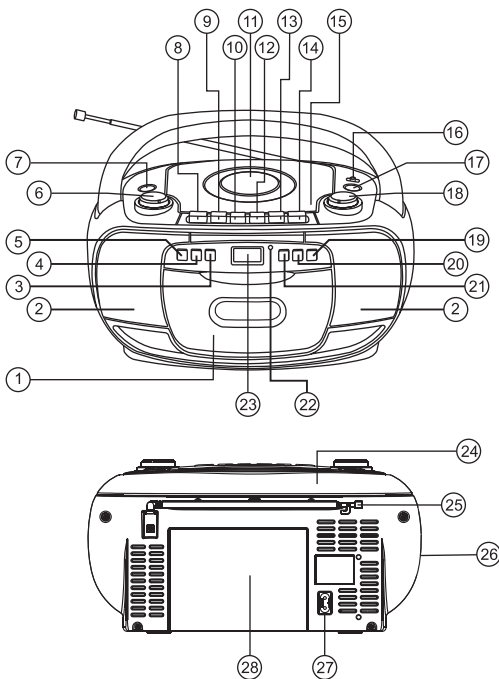

- | | |
|------------------------------------|-------------------------------------|
| 1. TAPA DEL CASETE | 15. BOTÓN DE APERTURA/CIERRE DEL CD |
| 2. ALTAVOZ | 16. INTERRUPTOR DE BANDA |
| 3. BOTÓN BACK DEL CD ◀◀ | 17. BOTÓN FUNCTION |
| 4. BOTÓN STOP DEL CD ■ | 18. CONTROL DE SINTONIZACIÓN |
| 5. BOTÓN PROGRAM/CLOCK-ADJ. DEL CD | 19. BOTÓN PLAY MODE DEL CD |
| 6. CONTROL DEL VOLUMEN | 20. BOTÓN NEXT DEL CD ▶▶ |
| 7. BOTÓN DE ENCENDIDO ⏻ | 21. BOTÓN PLAY/PAUSE DEL CD ▶▶ |
| 8. BOTÓN PAUSE DEL CASETE | 22. INDICADOR DE FM ESTÉREO |
| 9. BOTÓN STOP/EJECT DEL CASETE ■ ▲ | 23. PANTALLA LCD |
| 10. BOTÓN F.FWD DEL CASETE ◀◀ | 24. ASA |
| 11. TAPA DEL COMPARTIMENTO DEL CD | 25. ANTENA TELESCÓPICA |
| 12. REWIND DEL CASETE ▶▶ | 26. CONECTOR DE ENTRADA AUX IN |
| 13. BOTÓN PLAY DEL CASETE ◀ | 27. CONEXIÓN DEL CABLE ELÉCTRICO |
| 14. BOTÓN RECORD DEL CASETE ● | 28. COMPARTIMENTO DE LAS PILAS |

FUENTE DE ALIMENTACIÓN

USO DE CORRIENTE ELÉCTRICA DOMÉSTICA

Antes de utilizar el equipo, compruebe que su voltaje coincida con la tensión de la red local.

Nota: el enchufe de alimentación se usa como dispositivo de desconexión y ha de permanecer fácilmente accesible.

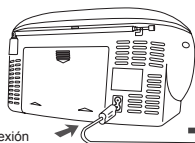

A conexión corriente equipo

Al suministro de corriente

USO DE PILAS

Desconecte el cable de alimentación de la entrada de corriente del equipo.

El funcionamiento con pilas se interrumpe automáticamente cuando el cable está conectado.

tapa del compartimento de las pilas

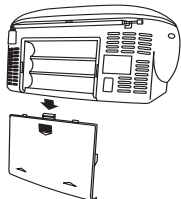

En caso de disminución del volumen o de distorsión del sonido, cambie todas las pilas por otras nuevas.

Introducir seis pilas UM-2 (tamaño C).

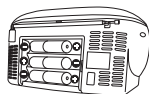

SISTEMA DE ENCENDIDO/APAGADO (ON/OFF)

Pulse el botón POWER  para encender el audio.

Para cambiar el modo de audio entre RADIO, AUX, TAPE y CD, pulse el botón FUNCTION con el equipo encendido.

Se visualizará el modo de audio.

Apague el equipo pulsando el botón POWER .

En la pantalla aparecerá la palabra «OFF»

y luego se volverá a ver la hora actual.



ENCENDIDO/APAGADO



FUNCTION



Pantalla LCD

Entrada AUX IN

Se puede conectar a este equipo una fuente (auxiliar) de audio externa (como un reproductor de MP3 o de CD personal) y escucharla a través de los altavoces.

- 1) Conecte un extremo del cable en el conector de entrada auxiliar AUX IN de este equipo.
- 2) Conecte el otro extremo del cable en el conector de salida de línea o auriculares de la fuente externa.
- 3) Pulse el botón FUNCTION para seleccionar AUX.

A continuación, utilice el reproductor de CD o MP3 del modo habitual.

El sonido se escuchará a través de los altavoces del equipo.

El equipo se apagará automáticamente si no se utiliza en 4,5 horas.

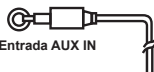

Entrada AUX IN

(Conecte el otro extremo a la fuente externa, como un reproductor de MP3).



FUNCTION



Pantalla LCD

AJUSTE DEL SONIDO

PARA AJUSTAR EL VOLUMEN



AJUSTE DEL RELOJ

En el modo standby, la pantalla LCD muestra el reloj.

1. Mantenga pulsado el botón PROGRAM/CLOCK-ADJ.
2. Pulse el botón ►►► NEXT o ◄◄◄ BACK para seleccionar la configuración del reloj para 12 ó 24 horas.
3. Pulse el botón PROGRAM/CLOCK-ADJ. y verá parpadear los dígitos de la hora.
4. Pulse el botón ►►► NEXT o ◄◄◄ BACK para ajustar los dígitos de la hora.
5. Pulse el botón PROGRAM/CLOCK-ADJ. y verá parpadear los dígitos de los minutos.
6. Pulse el botón ►►► NEXT o ◄◄◄ BACK para ajustar los dígitos de los minutos.
7. Al pulsar de nuevo el botón PROGRAM/CLOCK-ADJ., la hora introducida aparecerá en la pantalla.



CÓMO ESCUCHAR LA RADIO

1. Encienda el equipo pulsando el botón POWER .



2. Pulse el botón FUNCTION para seleccionar RADIO.

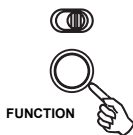
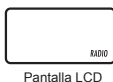

3. Seleccione una banda.

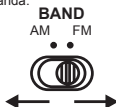

PARA MEJORAR LA RECEPCIÓN

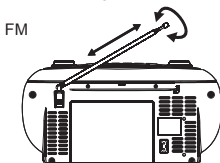

4. Sintonicé una emisora.

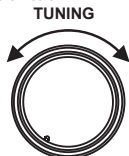

5. Ajuste el sonido.

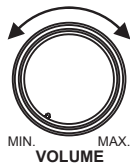

DESPUÉS DE HABER ESCUCHADO LA RADIO

Apague el equipo pulsando el botón POWER.

REPRODUCCIÓN DE DISCOS COMPACTOS

1. Encienda el equipo pulsando el botón POWER .



ENCENDIDO/APAGADO

2. Pulse el botón FUNCTION para seleccionar el modo CD. El símbolo «-» parpadeará para buscar el CD



Pantalla LCD

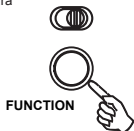

FUNCTION

3. Abra la tapa del compartimento del CD pulsando el botón de apertura y cierre del CD.



4. Introduzca un disco con la cara de la etiqueta hacia arriba.



5. Cierre la tapa del compartimento del CD. El disco girará y la pantalla mostrará el número total de pistas.

6. Pulse el botón PLAY/PAUSE . En la pantalla aparecerán el número de pista «01» y el símbolo «▶».



Pantalla LCD



PARA DETENER LA REPRODUCCIÓN

Pulse el botón PLAY/PAUSE  y el símbolo «▶» aparecerá parpadeando. Pulse de nuevo el botón para reanudar la reproducción.



Pantalla LCD







PARA DETENER LA REPRODUCCIÓN

Pulse el botón STOP  y en la pantalla se verá el número total de pistas del disco.



PARA SALTAR AL COMIENZO DE UNA PISTA

- Pulse uno de los botones  u  en función de dónde se encuentre la pista deseada.
- La reproducción se reanuda desde la pista seleccionada.
- Cuando se pulsa una vez el botón  durante la reproducción, comienza de nuevo la pista anterior.
- Cuando se pulsa una vez el botón  durante la reproducción, se reproduce la pista siguiente.

BÚSQUEDA DE UNA SECCIÓN DENTRO DE UNA PISTA

- Mantenga pulsado el botón  u  durante la reproducción y suéltelo en cuanto escuche la sección que desee. Entonces la reproducción normal del CD se reanuda desde ese punto.



El equipo se apagará automáticamente si no se utiliza en 30 minutos (en el modo STOP/compartimento del CD abierto).

REPETIR, REPETIR TODO Y REPRODUCCIÓN MIXTA

Pulse el botón PLAY durante el modo de parada. El CD se reproduce repitiendo una sola pista, todas las pistas o en orden aleatorio.

MODO DE REPRODUCCIÓN

PARA LA REPRODUCCIÓN NORMAL DEL CD

Secuencia de modo REPEAT >> REPEAT ALL >> MIX >> CLEAR.

Durante el modo de repetición Repeat 1, la pantalla muestra



Durante el modo de repetición Repeat 2, la pantalla muestra



Pantalla LCD

Durante el modo de reproducción mixta Mix, la pantalla muestra



Pantalla LCD



REPRODUCCIÓN PROGRAMADA

La reproducción programada permite reproducir un disco en el orden deseado. Se pueden programar hasta 20 pistas.

1. Pulse el botón PROGRAM.
2. Pulse los botones «NEXT» y «BACK» para pasar al número de pista deseado.
3. Pulse de nuevo el botón PROGRAM para memorizar la pista.
4. Repita los pasos 2 y 3 hasta haber programado todas las pistas deseadas.
5. Pulse el botón PLAY/PAUSE para comenzar la reproducción. En la pantalla del CD aparecerán «▶», «PROG» y el número de pista.
6. Pulse una vez el botón STOP para detener la reproducción programada.

7. Pulse el botón PLAY/PAUSE para reanudar la reproducción programada.
8. Abra la tapa del compartimento del CD, apague el reproductor de CD o pulse el botón STOP dos veces para borrar la memoria programada.

Nota: la programación sólo se puede llevar a cabo cuando el reproductor se encuentra en el modo STOP.

PROGRAMACIÓN



Pantalla LCD

Nota sobre los discos CD-R/RW

- Debido a la definición/producción de formatos no estandarizados de CD-R/RW, no se garantizan la calidad ni los resultados de su reproducción.
- El fabricante no se responsabiliza de la capacidad de reproducción de los CD-R/RW debido a las condiciones de grabación, como rendimiento del PC, software de escritura, capacidad de los medios, etc.
- No pegue ningún sello o etiqueta a ningún lado del disco CD-R/RW, ya que esto podría afectar a su funcionamiento.
- Se recomienda grabar únicamente archivos de audio en los discos CD-R/RW para facilitar la lectura.

REPRODUCCIÓN DE CASETES

1. Encienda el equipo pulsando el botón POWER .



POWER

2. Pulse el botón FUNCTION para seleccionar el modo TAPE.



FUNCTION



Pantalla LCD

3. Introduzca el casete.



4. Pulse de nuevo el botón  PLAY.



PLAY

PARA DETENER LA REPRODUCCIÓN

Pulse el botón STOP/EJECT.

PARA DETENER LA REPRODUCCIÓN

Pulse el botón PAUSE.

Pulse de nuevo el botón PAUSE para reanudar la reproducción.

PARA RETROCEDER O AVANZAR RÁPIDAMENTE

Pulse el botón REWIND (rebobinado) o F.FWD (avance rápido). Pulse el botón STOP/EJECT para dejar de retroceder o avanzar al llegar a la posición deseada.

CÓMO GRABAR

UTILICE SÓLO CINTAS NORMALES (TIPO 1) PARA LA GRABACIÓN.

1. Introduzca la cinta de casete.



2. Pulse el botón PAUSE .



3. Pulse el botón RECORD .



4. Prepare la fuente que desee grabar y reproducir, pulsando para ello el botón FUNCTION para seleccionar el modo CD o RADIO.

Grabación de un CD



REPRODUZCA EL CD

Grabación de la radio



SINTONICE UNA EMISORA

5. Pulse el botón PAUSE .



PARA DETENER LA GRABACIÓN

Pulse el botón STOP/EJECT.

PARA INTERRUPIR LA GRABACIÓN

Pulse el botón PAUSE.

Pulse de nuevo el botón PAUSE para reanudar la grabación.

PARA BORRAR UNA CINTA GRABADA

1. Pulse el botón FUNCTION para seleccionar el modo TAPE.
2. Introduzca la cinta de manera que quede mirando hacia usted el lado que desee borrar.
3. Pulse el botón RECORD para comenzar el borrado.

MANTENIMIENTO

LIMPIEZA DE UN CD

Si un CD salta o no se puede reproducir, es posible que haya que limpiarlo. Antes de la reproducción, limpie el disco con un paño desde el centro hacia el borde exterior. Después de la reproducción, ~~limpie~~ limpie el disco en su caja.



LIMPIEZA DEL EQUIPO

No utilice sustancias químicas volátiles con este equipo. Efectúe la limpieza pasando un paño suave.

NOTA IMPORTANTE

Si hubiera alguna indicación anómala en la pantalla o se produjera algún problema de funcionamiento, desconecte el cable de alimentación y quite las pilas. Espere al menos 5 segundos antes de volver a conectar el cable de alimentación o colocar las pilas.

LIMPIEZA DE LA LENTE DEL CD

Si la lente del CD tiene polvo, límpiela con un pincel soplador. Dirija aire hacia la lente con el soplador varias veces y retire el polvo con el pincel. Las huellas dactilares se pueden quitar con un bastoncillo de algodón humedecido en alcohol.

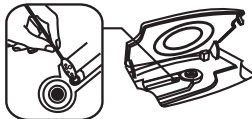

ADVERTENCIA

En caso de abrirse la tapa del compartimento del CD antes de haber finalizado la lectura del CD, se puede producir un sonido de atasco, que se resuelve cerrando la tapa del compartimento del CD.



CARACTERÍSTICAS TÉCNICAS

CASETE

| | |
|--------------------------|-----------------------------------|
| Formato de pistas: | 2 pistas estéreo |
| Sistema de grabación: | Corriente de polarización alterna |
| Sistema de borrado: | Borrado magnético 6 polos |
| Velocidad de la cinta: | 4,75 cm/seg. |
| Tiempo de F.F. y REW: | 170 seg. (cintas F-60) |
| Respuesta de frecuencia: | 125 Hz - 8000 Hz (cinta normal) |

CD

| | |
|------------------------------|--------------------------------------|
| Canales: | 2 canales |
| Relación señal-ruido: | 60 dB |
| Ululación y vibración: | Inapreciable |
| Frecuencia de muestreo: | 44.1 kHz 8 x sobremuestreo |
| Cuantificación: | convertor digital-analógico de 1 bit |
| Fuente de luz del lector: | Láser semiconductor |
| Longitud de onda del lector: | 790 nm |

RADIO

| | |
|-------------------------|---------------------------------------------------------------------|
| Gamas de sintonización: | FM 87.5-108MHz AM 522 - 1620 kHz |
| Antena: | De barra de ferrita para AM, incorporada Antena de FM de varilla |

GENERAL

| | |
|-----------------------------|-------------------------------------------------------|
| Potencia de salida: | 1,2 W + 1,2 W (RMS) |
| Consumo de energía: | 9,5 W |
| Conector de entrada AUX IN: | 3,5 mm |
| Altavoces: | 3" (7,62 cm) 8 ohmios |
| Suministro eléctrico: | CA: 230 V ~ 50 Hz CC: 9 V (6 x 1,5 V LR14"/C"/UM2) |

| | |
|--------------|----------------------------------|
| Dimensiones: | 294 (L) x 206 (Pr) x 153 (Al) mm |
| Peso | 1,72 kg |

Debido a las mejoras continuas, las características y el diseño podrían modificarse sin aviso previo.

Dónde colocar el artículo:

Los muebles actuales están recubiertos de una gran variedad de barnices y revestimientos sintéticos que se tratan con una amplia gama de productos de limpieza. Por tanto, no se puede excluir la posibilidad de que algunas de estas sustancias incluyan componentes que puedan reaccionar con las patas de goma del artículo y las ablanden. Las patas de goma del aparato pueden decolorar la superficie de los muebles. Si fuera necesario, coloque el aparato sobre una superficie antideslizante.

Observa: Con el fin de ahorrar energía, cuando él no emite sonido durante un momento, el aparato será puesto automáticamente en víspera. Para volverlo a poner en funcionamiento, le basta con seleccionar una función de nuevo.

No tire los aparatos eléctricos o electrónicos a la basura normal.

- Líveelos a un punto de recogida de este material,
- Ya que algunas piezas de estos aparatos pueden ser dañinos para la salud o el medio



Fabricado por BIGBEN INTERACTIVE SA
396, Rue de la Voyette
CRT2 - FRETIN
CS 90414
59814 LESQUIN Cedex - Francia
www.bigben.eu
Fabricado en China



bigben

Fabricant : Bigben Interactive FRANCE

396, Rue de la Voyette, C.R.T. 2 Fretin,
CS 90414 - 59814 LESQUIN Cedex

Bigben Interactive DEUTSCHLAND GmbH

Walter Gropius Str. 28, 50126 Bergheim, Deutschland

Bigben Interactive BELGIUM

Avenue Ernest Solvay, 1480 Tubize, Belgique

Bigben Interactive NEDERLAND b.v.

Franciscusweg 249-3B, 1216 SG Hilversum, Nederland

Bigben Interactive SPAIN S.L.

C/ Musgo 5, 2ª planta, 28023 Madrid, Spain

Bigben Interactive ITALIA s.r.l

Corso Sempione 221, 20025 Legnano - MI, Italia

FABRIQUÉ EN CHINE / MADE IN CHINA

HOTLINE

FRANCE, du lundi au vendredi (sauf jours fériés) :
9h00-19h00 ou support@thomsonaudiovideo.eu

N°Cristal 09 69 32 59 62

APPEL NON SURTAXE

DEUTSCHLAND, Montag bis Sonntag von 8:00 bis 24:00 Uhr
09001-84 30 44* (0,49€/Min. aus dem deutschen Festnetz, Anrufe aus allen

Mobilfunknetzen nicht möglich) oder support@bigben-interactive.de

*Minderjährige müssen vorher einen Erziehungsberechtigten um Erlaubnis fragen.

BELGIQUE / NEDERLAND, klantenservice@bigben-interactive.nl
customerservice@bigben-interactive.be

ESPAÑA, sat@bigbeninteractive.es

ITALIA, support@bigbeninteractive.it

www.bigben.eu

THOMSON es una marca registrada de TECHNICOLOR SA o de sus filiales utilizada
bajo licencia concedida a Bigben Interactive.

ES-10

THOMSON

RK200CD

LETTORE CD PORTATILE CON RADIO E RIPRODUTTORE MUSICASSETTE



ISTRUZIONI D'USO

**PRIMA DI UTILIZZARE L'APPARECCHIO, LEGGERE PER
INTERO IL PRESENTE MANUALE E CONSERVARLO
PER CONSULTAZIONI FUTURE.**

AVVERTENZA

PRODOTTO LASER DI CLASSE 1

CLASS 1 LASER PRODUCT
APPAREIL À LASER DE CLASSE 1
PRODUCTO LASER DE CLASE 1

ATTENZIONE
PRESENZA DI RADIAZIONI LASER
INVISIBILI QUANDO L'APPARECCHIO
È APERTO ED IL DISPOSITIVO DI
BLOCCAGGIO È SBLOCCATO. EVITARE
L'ESPOSIZIONE AL RAGGIO LASER



Questo apparecchio è dotato di un dispositivo laser di bassa potenza.

Avvertenza: non toccare la lente.

NON GETTARE LE BATTERIE NEL FUOCO.

PRECAUZIONI

Per un funzionamento corretto e sicuro, attenersi alle raccomandazioni specificate di seguito.

POSIZIONAMENTO

- Non utilizzare l'apparecchio in luoghi estremamente caldi, freddi, polverosi o umidi.
- Posizionare l'apparecchio su una superficie piana e uniforme.
- Non collocare l'apparecchio in un luogo con scarsa circolazione di aria, non coprirlo con un panno, né sistemarlo su un tappeto per evitare di limitare il flusso dell'aria.

SICUREZZA

- Per collegare e scollegare il cavo di alimentazione CA, afferrare la spina e non il cavo stesso. Tirando il cavo si rischia di danneggiarlo e di generare situazioni di pericolo.
- Quando si prevede di non utilizzare l'apparecchio per un periodo di tempo prolungato, scollegare il cavo di alimentazione CA.

TENSIONE DI ALIMENTAZIONE CA

- Prima dell'uso, controllare che la tensione nominale dell'apparecchio corrisponda alla tensione locale.

CONDENSA

- Quando il lettore CD viene lasciato in una stanza riscaldata il cui ambiente è caldo e umido, è possibile che si formino goccioline d'acqua o di condensa all'interno del lettore stesso.
- In caso di condensa all'interno dell'apparecchio, questo potrebbe non funzionare normalmente.
- Attendere 1 o 2 ore prima di accendere l'apparecchio, oppure raffreddare gradualmente la stanza e asciugare l'apparecchio prima dell'uso.
- Per consentire una ventilazione adeguata, verificare che attorno all'apparecchio vi sia uno spazio libero di minimo 5 cm.
- Assicurarsi di non ostacolare la ventilazione ostruendo le aperture di aerazione con oggetti quali giornali, tovaglie, tende, ecc.
- Non collocare sull'apparecchio fonti di fiamme vive, quali ad esempio candele accese.
- Prestare attenzione agli aspetti relativi alla tutela dell'ambiente legati allo smaltimento delle batterie usate.
- Utilizzare l'apparecchio unicamente in aree a clima temperato.
- Non esporre l'apparecchio a spruzzi o schizzi.
- Non collocare sull'apparecchio oggetti contenenti liquidi, quali ad esempio vasi.
- Le batterie non devono essere esposte a fonti di calore eccessivo come luce solare, fuoco o simili.
- L'accesso alla presa di corrente non deve essere ostruito e deve rimanere facilmente raggiungibile durante l'utilizzo.

Se si verificano problemi, scollegare il cavo di alimentazione CA e affidare eventuali operazioni di riparazione a personale di assistenza qualificato.



Il simbolo del fulmine con la freccia racchiuso nel triangolo serve ad avvertire l'utente della presenza di "tensione pericolosa" all'interno del prodotto.

ATTENZIONE

PERICOLO DI SCOSSE
ELETTRICHE NON APRIRE

ATTENZIONE: Per ridurre il rischio di scosse elettriche, non aprire l'apparecchio. Al suo interno non vi sono parti o componenti riparabili dall'utente. Per qualsiasi operazione di riparazione, rivolgersi a personale di assistenza qualificato.



Il punto esclamativo all'interno del triangolo serve ad avvertire l'utente della presenza di istruzioni importanti che accompagnano il prodotto.

In caso di malfunzionamento dovuto a scariche elettrostatiche, è necessario resettare l'apparecchio scollegandolo dall'alimentazione elettrica.

LE INFORMAZIONI RELATIVE ALLA MARCATURA SI TROVANO SUL LATO POSTERIORE DELL'APPARECCHIO.

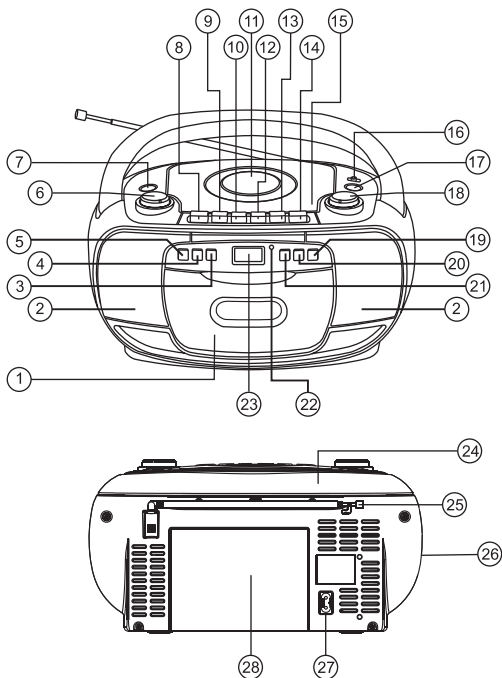

- | | |
|--------------------------------------|-------------------------------------------------|
| 1. SPORTELLO DEL VANO MUSICASSETTA | 15. TASTO APERTURA / CHIUSURA SPORTELLO VANO CD |
| 2. ALTOPARLANTE | 16. Selettore MODALITÀ BANDA |
| 3. TASTO BACK CD ◀◀ | 17. TASTO FUNCTION |
| 4. TASTO STOP CD ■ | 18. MANOPOLA DI SINTONIZZAZIONE |
| 5. TASTO CD PROGRAM/CLOCK-ADJ. | 19. TASTO CD PLAY MODEN |
| 6. REGOLAZIONE DEL VOLUME | 20. TASTO NEXT CD ▶▶ |
| 7. TASTO POWER ⏻ | 21. TASTO PLAY/PAUSE CD ▶ |
| 8. TASTO PAUSE MUSICASSETTA | 22. INDICATORE STEREO FM |
| 9. TASTO STOP/EJECT MUSICASSETTA ■ ▲ | 23. DISPLAY LCD |
| 10. TASTO F.FWD MUSICASSETTA ◀◀ | 24. MANIGLIA DI TRASPORTO |
| 11. SPORTELLO VANO CD | 25. ANTENNA TELESCOPICA |
| 12. TASTO REWIND MUSICASSETTA ▶▶ | 26. CONNETTORE INGRESSO AUX IN |
| 13. TASTO PLAY MUSICASSETTA ◀ | 27. PRESA DI ALIMENTAZIONE CA |
| 14. TASTO RECORD MUSICASSETTA ● | 28. VANO BATTERIA |

ALIMENTAZIONE

UTILIZZO DELLA CORRENTE DOMESTICA

Prima dell'uso, controllare che la tensione nominale dell'apparecchio corrisponda alla tensione locale.

Attenzione: La spina di alimentazione viene utilizzata per scollegare il dispositivo dall'alimentazione elettrica. Il dispositivo di scollamento deve rimanere facilmente accessibile.

UTILIZZO DELLE BATTERIE

Scollegare il cavo di alimentazione CA dall'ingresso CA dell'apparecchio. L'alimentazione a batteria viene interrotta automaticamente non appena il cavo

Sportello vano batteria

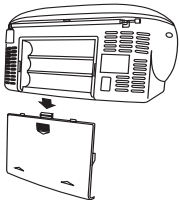

Alla presa di alimentazione CA

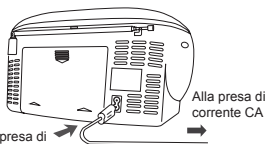



Alla presa di corrente CA

Quando il volume si riduce o l'audio risulta distorto, sostituire tutte le batterie con batterie nuove.

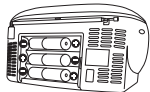
Inserire sei batterie UM-2 (tipo C).



ACCENSIONE / SPEGNIMENTO DEL SISTEMA

Premere il tasto POWER  per accendere l'apparecchio. Per selezionare la modalità audio tra RADIO, AUX, TAPE e CD premere il tasto FUNCTION quando l'apparecchio è acceso. Sul display viene visualizzata la modalità audio attiva. Spegnere l'unità premendo il tasto POWER . La dicitura "OFF" viene visualizzata sul display, seguita dell'ora corrente.



POWER



FUNCTION



Display LCD

AUX. IN

È possibile collegare al sistema una sorgente audio (ausiliaria) esterna (per es., un lettore CD o MP3) e riprodurre i brani mediante gli altoparlanti dell'impianto.

- 1) Inserire un'estremità del cavo nella presa "AUX IN" presente sull'unità.
- 2) Inserire l'altra estremità del cavo nella presa cuffie o "Line Out" della sorgente audio esterna.
- 3) Premere il tasto FUNCTION per selezionare la modalità AUX.

Proseguire la normale riproduzione con il lettore CD o MP3. I brani selezionati saranno riprodotti mediante gli altoparlanti dell'unità.

L'unità verrà disattivata automaticamente trascorse 4,5 ore dall'ultima operazione eseguita.



AUX. IN

(collegare l'altra estremità alla sorgente esterna, per es. un lettore MP3)

FUNCTION



Display LCD

REGOLAZIONE DEL VOLUME DI RIPRODUZIONE

REGOLAZIONE DEL VOLUME



MIN.

MAX.

VOLUME

REGOLAZIONE DELL'OROLOGIO

1. Premere e tenere premuto il tasto PROGRAM / CLOCK-ADJ.
2. Premere il tasto ►►► NEXT o il tasto ◄◄◄ BACK per selezionare la modalità di visualizzazione a 12 ore o a 24 ore.
3. Premere il tasto PROGRAM / CLOCK-ADJ.: la cifra dell'ora lampeggia.
4. Premere il tasto ►►► NEXT o il tasto ◄◄◄ BACK per regolare la cifra dell'ora.
5. Premere il tasto PROGRAM / CLOCK-ADJ.: la cifra dei minuti lampeggia.
6. Premere il tasto ►►► NEXT o il tasto ◄◄◄ BACK per regolare la cifra dei minuti.
7. Premere nuovamente il tasto PROGRAM / CLOCK-ADJ.: sul display viene visualizzato l'orario corretto.

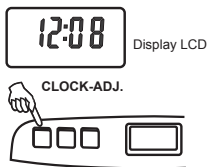

ASCOLTO DELLA RADIO

1. Accendere l'unità premendo il tasto POWER .



2. Premere il tasto FUNCTION per selezionare la modalità RADIO.

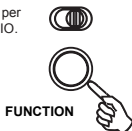

3. Selezionare una banda radio.

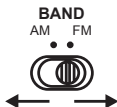

4. Sintonizzarsi su una emittente radio.

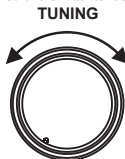

5. Regolare il volume audio di riproduzione.



PER UNA MIGLIORE RICEZIONE

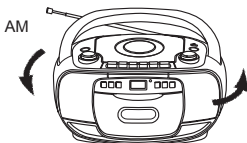
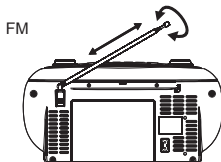

DOPO L'ASCOLTO

Disattivare l'unità premendo il tasto "POWER".

RIPRODUZIONE DI COMPACT DISC

1. Accendere l'unità premendo il tasto POWER .



2. Premere il tasto FUNCTION per selezionare la modalità CD. La dicitura "___" inizierà a lampeggiare sul display per indicare la ricerca del disco CD.

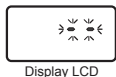

Display LCD





3. Aprire lo sportello del vano CD premendo l'apposito tasto di apertura / chiusura.



4. Inserire un disco con il lato dell'etichetta rivolto verso l'alto.

5. Chiudere lo sportello del vano CD. Verrà avviata la lettura del disco: sul display verrà visualizzato il numero totale dei brani presenti nel disco.





6. Premere il tasto PLAY/PAUSE . Verranno visualizzati sul display il numero del brano "01" e il simbolo .



Display LCD



INTERRUZIONE DELLA RIPRODUZIONE

Premere il tasto PLAY / PAUSE : il simbolo  lampeggia sul display. Premere nuovamente il tasto per ripristinare la riproduzione.



Display LCD







ARRESTO DELLA RIPRODUZIONE



Premere il tasto STOP : sul display viene visualizzato il numero totale dei brani.



PASSAGGIO ALL'INIZIO DI UN BRANO

- Premere uno dei tasti  o  a seconda della direzione di ricerca desiderata.
- La riproduzione viene ripristinata dal brano selezionato.
- Premendo una volta il tasto  durante la riproduzione, viene riavviata la riproduzione del brano precedente.
- Premendo una volta il tasto  durante la riproduzione, viene riavviata la riproduzione del brano successivo.

RICERCA DI UN PASSAGGIO ALL'INTERNO DI UN BRANO

- Tenere premuto il tasto  o il tasto  durante la riproduzione, quindi rilasciare il tasto non appena si riconosce il passaggio desiderato. La normale riproduzione del CD verrà ripristinata da questo punto.



L'unità verrà disattivata automaticamente trascorsi 30 minuti dall'ultima operazione eseguita (in modalità di arresto / sportello del vano CD aperto).

RIPETIZIONE, RIPETIZIONE INTEGRALE E RIPRODUZIONE CASUALE

Premere il tasto PLAY MODE durante la modalità di arresto. Il CD esegue la riproduzione ripetuta di un singolo brano, di tutti i brani oppure la riproduzione in modalità casuale.

MODALITÀ DI RIPRODUZIONE

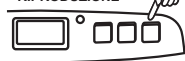

PER LA NORMALE RIPRODUZIONE DEL COMPACT DISC

Sequenza modalità: RIPETIZIONE >> RIPETIZIONE INTEGRALE >> RIPETIZIONE CASUALE >> ANNULLA.

Durante la modalità di ripetizione 1, sul display viene visualizzato



Durante la modalità di ripetizione casuale, sul display viene visualizzato



Display LCD

Durante la modalità di ripetizione 2, sul display viene visualizzato



Display LCD

RIPRODUZIONE PROGRAMMATA

La riproduzione programmata consente di riprodurre nell'ordine desiderato i brani presenti in un disco. È possibile programmare fino a 20 brani per la riproduzione.

1. Premere il tasto PROGRAM.
2. Premere i tasti di ricerca NEXT e BACK per selezionare il numero del brano desiderato.
3. Premere nuovamente il tasto PROGRAM per memorizzare il brano.
4. Ripetere i passaggi 2 e 3 fino a programmare tutti i brani desiderati.
5. Premere il tasto "PLAY / PAUSE" per iniziare. Sul display del CD saranno visualizzate le diciture "▶", "PROGRAM" e il numero del brano.
6. Premere una volta il tasto STOP per arrestare la riproduzione programmata.

7. Premere il tasto PLAY / PAUSE per ripristinare la riproduzione programmata.
8. Aprire lo sportello del vano CD, disattivare il lettore CD o premere due volte il tasto STOP per cancellare i brani memorizzati.

Nota: la programmazione può avvenire soltanto se il lettore si trova in modalità di arresto.



"PROGRAMMAZIONE"



Display LCD

Nota sui dischi CD-R/RW

- A causa della definizione / produzione di formati non standard di CD-R/RW, non è possibile garantire le prestazioni e la qualità della riproduzione.
- Il produttore declina ogni responsabilità in caso di problemi di leggibilità di CD-R/RW dovuti alle condizioni di registrazione, quali prestazioni del PC, software di scrittura, capacità del supporto, ecc.
- Non apporre sigilli o etichette su entrambi i lati del CD-R/RW, in quanto potrebbero causare un malfunzionamento.
- Per facilitare la lettura, si raccomanda di registrare su dischi CD-R/RW unicamente file audio.

RIPRODUZIONE DI MUSICASSETTE

1. Accendere l'unità premendo il tasto POWER



POWER

2. Premere il tasto FUNCTION per selezionare la modalità TAPE.



FUNCTION



Display LCD

3. Inserire la musicassetta nell'apposito vano.



4. Premere il tasto PLAY

PLAY



ARRESTO DELLA RIPRODUZIONE

Premere il tasto STOP / EJECT.

INTERRUZIONE DELLA RIPRODUZIONE

Premere il tasto PAUSE.

Per riprendere la riproduzione, premere nuovamente il tasto PAUSE.

AVANZAMENTO VELOCE

Premere il tasto REWIND o F.FWD. Premere il tasto STOP/ EJECT per arrestare l'avanzamento o il riavvolgimento veloce alla posizione desiderata.

REGISTRAZIONE

ATTENZIONE: PER LA REGISTRAZIONE UTILIZZARE SOLTANTO MUSICASSETTE NORMALI (TYPE I).

1. Inserire la musicassetta nell'apposito vano.



2. Premere il tasto PAUSE .



3. Premere il tasto RECORD .



4. Predisporre la sorgente da registrare e avviare la riproduzione. Premere il tasto FUNCTION per selezionare la modalità CD o RADIO.

Registrazione dal CD



RIPRODURRE IL CD

Registrazione dalla RADIO



SINTONIZZARSI SU UNA EMITTENTE RADIO

5. Premere il tasto PAUSE .



ARRESTO DELLA REGISTRAZIONE

Premere il tasto STOP / EJECT

INTERRUZIONE DELLA REGISTRAZIONE

Premere il tasto PAUSE.

Per riprendere la registrazione, premere di nuovo il tasto PAUSE.

CANCELLAZIONE DI UNA REGISTRAZIONE

1. Premere il tasto FUNCTION per selezionare la modalità TAPE.
2. Inserire la musicassetta con il lato che si desidera cancellare rivolto verso l'esterno.
3. Premere il tasto RECORD per avviare la cancellazione.

MANUTENZIONE

PULIZIA DEL CD

Se la riproduzione del CD è difettosa o non avviene, è probabile che il disco debba essere pulito. Prima della riproduzione, pulire il disco dal centro verso l'esterno con un panno.

Dopo la riproduzione, riporre il disco nella relativa custodia.



PULIZIA DELL'APPARECCHIO

Non utilizzare sostanze chimiche volatili sull'apparecchio. Pulire l'apparecchio strofinandolo leggermente con un panno morbido.

NOTA IMPORTANTE

Qualora dovesse apparire sul display un'indicazione di anomalia o si dovesse verificare un problema di funzionamento, scollegare il cavo di alimentazione CA e rimuovere le batterie. Attendere almeno 5 secondi, quindi ricollegare il cavo di alimentazione CA o reinserire le batterie.

PULIZIA DELLALENTE DEL CD

Se la lente del CD è impolverata, pulirla con una spazzola a soffietto. Soffiare più volte sulla lente e asportare la polvere con la spazzola. Le impronte digitali possono essere rimosse con un tampone di cotone inumidito con alcol.

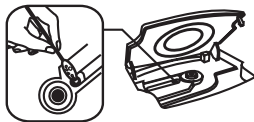

AVVERTENZA

Se si apre lo sportello del vano CD prima del completamento della lettura del CD, è possibile avvertire un rumore di disturbo. Il problema si risolve chiudendo lo sportello CD.

SEZIONE MUSICASSETTE

| | |
|-------------------------------|-----------------------------------|
| Formato brano: | stereo a 2 canali |
| Sistema di registrazione: | polarizzazione CA |
| Sistema di cancellazione: | magnetico a 6 poli |
| Velocità nastro: | 4,75 cm / sec. |
| Tempo avanz. e riavv. veloce: | 170 sec. (musicassette F-60) |
| Risposta in frequenza: | 125 Hz - 8000 Hz (nastro normale) |

SEZIONE CD

| | |
|-------------------------------------|---------------------------------|
| Canali: | 2 canali |
| Rapporto S/N: | 60 dB |
| Wow e Flutter: | impercettibile |
| Frequenza di campionamento: | 44,1 kHz 8 x sovracampionamento |
| Quantizzazione: | convertitore DA 1 bit |
| Fonte luminosa ricezione segnale: | laser a semiconduttore |
| Lunghezza d'onda ricezione segnale: | 790 nm |

SEZIONE RADIO

| | |
|------------------|-----------------------------------------------------------------------------------|
| Gamme frequenze: | FM 87.5 - 108 MHz AM 522 - 1620 kHz |
| Antenne: | integrata a barra in ferrite per ricezione AM antenna ad asta per ricezione FM |

GENERALI

| | |
|-----------------------------|---------------------------------------------------------|
| Potenza in uscita: | 1,2 W + 1,2 W (RMS) |
| Consumo energetico: | 9,5 W |
| Connettore ingresso AUX IN: | 3,5 mm |
| Altoparlanti: | 3" 8 ohm |
| Alimentazione: | CA: 230 V ~ 50 Hz CC: 9V (6 x 1,5 V LR14 / "C" /UM2) |
| Dimensioni: | 294 (L) x 206 (P) x 153 (A) mm |
| Peso: | 1,72 kg |

A causa dei continui miglioramenti tecnici, il design e le specifiche sono soggetti a modifica senza preavviso.

Collocazione del prodotto

I mobili moderni sono rivestiti con un'ampia varietà di lacche e rivestimenti sintetici che possono essere trattati con svariati prodotti detergenti. Pertanto, il rischio che alcune di queste sostanze contengano componenti in grado di aggredire e danneggiare i piedini in gomma del prodotto non può essere completamente escluso. I piedini in gomma dell'apparecchio possono provocare lo scolorimento delle superfici dei mobili. Se necessario, collocare l'apparecchio su una superficie non scivolosa.

Nota: Per risparmiare energia, quando non emette alcun suono per qualche tempo, l'unità sarà essere messo in pausa automaticamente. Per reinstallare l'operazione, basta selezionare una funzione ancora.

Non gettare gli apparecchi elettrici ed elettronici tra i rifiuti indifferenziati.

- Depositare o consegnare gli apparecchi presso un apposito punto di raccolta.
- Alcuni componenti contenuti in questi apparecchi possono essere pericolosi per la salute e per l'ambiente



Prodotto da BIGBEN INTERACTIVE SA
396, Rue de la Voyette
CRT2 - FRETIN
CS 90414
59814 LESQUIN Cedex - Francia
www.bigben.eu
Prodotto in Cina



bigben

Fabricant : Bigben Interactive FRANCE

396, Rue de la Voyette, C.R.T. 2 Fretin,
CS 90414 - 59814 LESQUIN Cedex

Bigben Interactive DEUTSCHLAND GmbH

Walter Gropius Str. 28, 50126 Bergheim, Deutschland

Bigben Interactive BELGIUM

Avenue Ernest Solvay, 1480 Tubize, Belgique

Bigben Interactive NEDERLAND b.v.

Franciscusweg 249-3B, 1216 SG Hilversum, Nederland

Bigben Interactive SPAIN S.L.

C/ Musgo 5, 2ª planta, 28023 Madrid, Spain

Bigben Interactive ITALIA s.r.l

Corso Sempione 221, 20025 Legnano - MI, Italia

FABRIQUÉ EN CHINE / MADE IN CHINA

HOTLINE

FRANCE, du lundi au vendredi (sauf jours fériés) :
9h00-19h00 ou support@thomsonaudiovideo.eu

N°Cristal 09 69 32 59 62

APPEL NON SURTAXE

DEUTSCHLAND, Montag bis Sonntag von 8:00 bis 24:00 Uhr

09001-84 30 44* (0,49€/Min. aus dem deutschen Festnetz, Anrufe aus allen
Mobilfunknetzen nicht möglich) oder support@bigben-interactive.de

*Minderjährige müssen vorher einen Erziehungsberechtigten um Erlaubnis fragen.

BELGIQUE / NEDERLAND, klantenservice@bigben-interactive.nl
customerservice@bigben-interactive.be

ESPAÑA, sat@bigbeninteractive.es

ITALIA, support@bigbeninteractive.it

www.bigben.eu

THOMSON è un marchio di TECHNICALOR SA o delle relative affiliate, utilizzato su
licenza concessa a Bigben Interactive.

THOMSON

RK200CD

LEITOR DE CD PORTÁTIL COM LEITOR DE RÁDIO E CASSETE



INSTRUÇÕES DE FUNCIONAMENTO

**LEIA ESTE MANUAL DE UTILIZADOR COMPLETAMENTE ANTES
UTILIZAR ESTA UNIDADE E MANTENHA ESTE FOLHETO PARA
REFERÊNCIA FUTURA.**



AVISO

PRODUTO LASER DE CLASSE 1

CLASS 1 LASER PRODUCT
APPAREIL À LASER DE CLASSE 1
PRODUCTO LASER DE CLASE 1

CUIDADO
RADIACÃO LASER INVISÍVEL AO
ABRIR E CONTORNAR BLOQUEIOS.
EVITAR EXPOSIÇÃO A RAIOS



Este produto contém um dispositivo laser de baixo consumo.

Aviso: Não toque na lente.

NÃO ATIRAR AS PILHAS PARA O FOGO!

PRECAUÇÕES

Siga as recomendações abaixo para uma operação segura e apropriada.

SOBRE A LOCALIZAÇÃO

- Não utilize a unidade em locais extremamente quentes, frios, poeirentos ou húmidos.
- Coloque a unidade numa superfície plana e regular.
- Não restrinja a circulação de ar da unidade, colocando-a num local com má circulação de ar, cobrindo-a com um pano ou colocando-a em cima de um tapete.

SOBRE SEGURANÇA

- Ao ligar e desligar o cabo CA, segure na ficha e não no cabo em si. Puxar o cabo pode danificá-lo e resultar em situações perigosas.
- Se não for utilizar a unidade durante um longo período de tempo, retire o cabo de alimentação CA da tomada.

SOBRE A VOLTAGEM CA

- Antes de utilizar, verifique que a tensão nominal da unidade corresponde à tensão local.

SOBRE CONDENSAÇÃO

- Se colocar o aparelho numa sala quente e húmida, podem-se formar, dentro do leitor de CDs, condensação ou gotículas de água.
- Quando existe condensação dentro da unidade, a unidade pode deixar de funcionar corretamente.
- Aguarde 1 a 2 horas antes de ligar o aparelho ou aqueça gradualmente a sala e seque a unidade antes de qualquer utilização.
- Certifique-se de que o aparelho tem uma distância mínima de 5 cm em seu redor para uma ventilação suficiente.
- Certifique-se de que a ventilação não é impedida através da cobertura das aberturas de ventilação com itens como, por exemplo, jornais, toalhas de mesa, cortinas, etc.
- Não coloque fontes de chama, como, por exemplo, velas acesas, em cima do aparelho.
- Preste atenção aos aspetos ambientais da eliminação das baterias.
- Utilize o aparelho apenas em climas amenos.
- Não expor o aparelho a pingos nem salpicos.
- Não coloque em cima do aparelho objetos com líquidos, como, por exemplo, vasos.
- A pilha não deve ser exposta a calor excessivo, como sol, fogo, ou semelhante.
- A ficha do aparelho não deve ser obstruída e deve estar facilmente acessível durante a utilização prevista.

Caso ocorra alguma anomalia, desconecte o cabo de alimentação CA e solicite a ajuda de pessoal qualificado.



O raio e a ponta da flecha no triângulo é o sinal de aviso alertando-o para "voltagem perigosa" presente no produto.

CUIDADO

RISCO DE CHOQUE ELÉTRICO
NÃO ABRIR

ATENÇÃO : Para reduzir o risco de choque elétrico, não remova a tampa. Não existem peças reparáveis pelo utilizador no interior. A manutenção deve ser realizada por pessoal qualificado.



O ponto de exclamação no triângulo é um sinal de aviso chamando a atenção para instruções importantes acerca do produto.

Em caso de avaria devido a descarga eletrostática, o aparelho deve ser reposto, desligando-o da ficha.

A INFORMAÇÃO SOBRE MARCAÇÃO ESTÁ LOCALIZADA NA PARTE TRASEIRA DO APARELHO.



LOCALIZAÇÃO DOS CONTROLOS

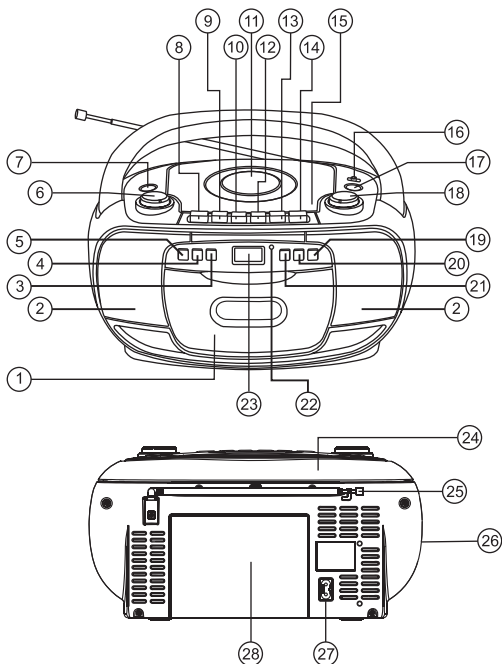

- | | |
|-----------------------------------|----------------------------------------|
| 1. PORTA DE CASSETE | 15. BOTÃO ABRIR/FECHAR CD |
| 2. ALTIFALANTE | 16. ALTERNAR BANDA |
| 3. BOTÃO RETROCEDER CD ◀◀ | 17. BOTÃO FUNÇÃO |
| 4. BOTÃO STOP CD ■ | 18. SINTONIZADOR |
| 5. BOTÃO PROGRAMA CD/DEF. RELÓGIO | 19. BOTÃO MODO REPRODUZIR CD |
| 6. CONTROLO DE VOLUME | 20. BOTÃO AVANÇAR CD ▶▶ |
| 7. BOTÃO DE ALIMENTAÇÃO ⏻ | 21. BOTÃO DE REPRODUÇÃO/PAUSA DE CD ▶▶ |
| 8. PAUSA CASSETE | 22. INDICADOR DE ESTÉREO FM |
| 9. STOP/EJEÇÃO CASSETE ■ ▲ | 23. VISOR LCD |
| 10. AVANÇAR CASSETE ◀◀ | 24. PEGA |
| 11. PORTA DO CD | 25. ANTENA TELESCÓPICA |
| 12. RECUAR CASSETE ▶▶ | 26. ENTRADA AUX IN. |
| 13. REPRODUZIR CASSETE ◀ | 27. ENTRADA CA |
| 14. GRAVAR CASSETE ● | 28. COMPARTIMENTO DA PILHA |

FONTE DE ENERGIA

UTILIZAR A CORRENTE DOMÉSTICA

Antes de utilizar, verifique que a tensão nominal da unidade corresponde à tensão local.

Nota: A ficha é utilizada como dispositivo para desligar o aparelho. O dispositivo para desligar o aparelho deve permanecer pronto a utilizar.

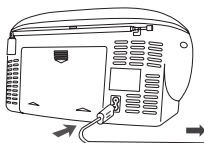

Para a tomada CA Para tomada CA

Logo que volume diminua ou o som fique distorcido, substitua todas as pilhas por novas..

UTILIZAR PILHAS

Desligue o cabo de alimentação CA da entrada de CA da unidade.

A alimentação da pilha é cortada automaticamente pelo cabo enquanto estiver conectado.

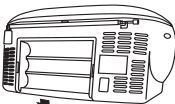

porta da pilha



Introduza seis pilhas UM-2 (tamanho C).

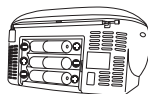

LIGAR/DESLIGAR O SISTEMA

Prima o BOTÃO DE ALIMENTAÇÃO  para ligar o áudio. Para alternar o modo áudio entre RÁDIO, AUX, CASSETE e CD, prima o botão FUNÇÃO com o aparelho ligado. O modo áudio é apresentado.

Desligue a unidade ao premir o BOTÃO DE ALIMENTAÇÃO . A palavra "OFF" será apresentada no ecrã e, em seguida, a hora atualizada.



Ecrã LCD

AUX. IN

É possível ligar uma fonte externa (auxiliar) de áudio (isto é, um leitor de CD ou um leitor de MP3) a esta unidade e ouvi-la através dos altifalantes.

- 1) Ligue uma ponta do cabo à entrada AUX IN da unidade.
- 2) Ligue a outra ponta do cabo a auscultadores ou à entrada Line Out da fonte externa.
- 3) Prima o botão FUNÇÃO para selecionar AUX.

Continue a utilizar o leitor de CD ou MP3 como habitualmente. As seleções serão audíveis através dos altifalantes da unidade.

A unidade é automaticamente desligada após 4h30m sem funcionar.

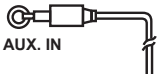

AUX. IN

(Conecte outra extremidade à fonte externa como um leitor de MP3.)



Ecrã LCD

AJUSTAR O SOM

PARA AJUSTAR O VOLUME



ACERTAR O RELÓGIO

O relógio é exibido no ecrã LCD no modo de espera.

1. Mantenha o botão PROGRAMA / DEF.RELÓG. premido.
2. Prima AVANÇAR ►► ou RETROCEDER ◄◄ para selecionar a visualização de 12 ou de 24 horas.
3. Prima o botão PROGRAMA/DEF.RELÓG e o dígito de hora fica intermitente.
4. Prima AVANÇAR ►► ou RETROCEDER ◄◄ para definir o dígito de hora.
5. Prima o botão PROGRAMAR/DEF.RELÓG e o dígito dos minutos começa a piscar.
6. Prima AVANÇAR ►► ou RETROCEDER ◄◄ para definir o dígito dos minutos.
7. Prima novamente o botão PROGRAMAR/DEF.RELÓG e a hora certa aparecerá no visor.



OUVIR RÁDIO

1. Ligue a unidade ao premir o BOTÃO DE ALIMENTAÇÃO .

ALIMENTAÇÃO



2. Prima o BOTÃO DE FUNÇÃO para selecionar RÁDIO.

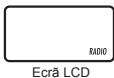

Ecrã LCD



FUNÇÃO

3. Selecione uma banda.

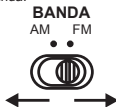

BANDA
AM FM

PARA MELHOR RECEÇÃO

FM



4. Sintonize uma estação.

SINTONIZAÇÃO

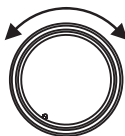

5. Ajuste o som.

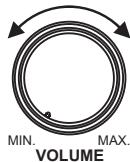

MIN. MAX.
VOLUME

DEPOIS DE OUVIR

Desligue a unidade premindo o botão LIGAR/DESLIGAR/ MODO DE SUSPENSÃO.

REPRODUÇÃO DE CD

1. Ligue a unidade ao premir o BOTÃO DE ALIMENTAÇÃO .



2. Prima o botão FUNÇÃO para selecionar o modo CD. O símbolo "CD" fica intermitente enquanto procura o CD.

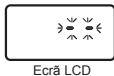

3. Abra a porta do CD, premindo o botão Abrir/Fechar CD.



4. Introduza um disco com o lado da etiqueta voltado para cima.
5. Feche a bandeja do CD. O disco irá rodar e o número total de faixas do disco é apresentado no ecrã.



6. Prima o botão REPRODUÇÃO/PAUSA . Serão apresentados o número da faixa "01" e o símbolo "▶".



PARA COLOCAR A REPRODUÇÃO EM PAUSA
Prima o botão Reprodução/Pausa  e o símbolo "▶" fica intermitente. Prima novamente o botão continuar a reprodução.







PARA PARAR A REPRODUÇÃO



Prima o botão STOP  e o ecrã mostra o total das faixas do disco.



PARA AVANÇAR PARA O PRINCÍPIO DE UMA FAIXA

- Prima os botões de retroceder e avançar  e  de acordo com o que pretende.
- A reprodução é retomada a partir da faixa selecionada.
- Quando o botão  é premido uma vez durante a reprodução, a faixa anterior recomeça.
- Quando o botão  é premido uma vez durante a reprodução, a faixa seguinte é reproduzida.

SLOCALIZAR UMA PASSAGEM NUMA FAIXA

- Mantenha o botão  ou  premido durante a reprodução e liberte o botão quando encontrar a passagem que deseja. Em seguida, a reprodução normal de CD retomará a partir deste ponto.



A unidade será automaticamente desligada após 30 minutos sem utilização (em modo de stop com a bandeja do CD aberta).

REPETIR, REPETIR TUDO E REPRODUÇÃO MISTA

Prima o botão MODO DE REPRODUÇÃO durante o modo de paragem. O CD reproduz repetidamente um único single, todas as faixas ou aleatoriamente.

MODO DE REPRODUÇÃO



PARA A REPRODUÇÃO NORMAL DE CD

Seqüência do modo REPETIR >> REPETIR TUDO >> MISTURA >> LIMPAR.

Durante o modo Repetição 1, no ecrã pode consultar



Durante o modo Mistura, no ecrã pode consultar



Ecrã LCD

Durante o modo Repetição 2, no ecrã pode consultar



Ecrã LCD

REPRODUÇÃO PROGRAMADA

O modo de reprodução programada permite-lhe reproduzir as faixas de um disco na ordem desejada. É possível programar até 20 faixas.

1. Prima o botão PROGRAMAR.
2. Prima os botões AVANÇAR e RETROCEDER para selecionar o número da faixa desejada.
3. Prima novamente o botão PROGRAMAR para memorizar a faixa.
4. Repita os passos 2 e 3 até que todas as faixas desejadas estejam programadas.
5. Prima o botão REPRODUZIR/PAUSA para começar. "►", "PROG" e o número da faixa são apresentados no ecrã CD.
6. Prima o botão "STOP" uma vez para parar a reprodução programada.
7. Prima o botão "REPRODUÇÃO/PAUSA" para retomar a reprodução programada.
8. Abra a porta do CD, desligue o leitor de CD ou prima o botão "STOP" duas vezes para limpar a memória programada.

Nota: Só é possível programar quando o leitor está em modo de paragem.



"PROGRAMA"



Ecrã LCD

Nota relativa aos discos CD-R/RW

- Não se garante a qualidade e o desempenho da reprodução devido à definição/produção do formação não padronizado do CD-R/RQ.
- O fabricante não é responsável pela reprodutibilidade do CD-R/RW devido às condições de reprodução, como desempenho do PC, software de escrita, propriedades de media, etc.
- Não coloque nenhum selo nem etiqueta em qualquer um dos lados do disco CDR-/RW pois pode causar uma avaria.
- É recomendado gravar apenas ficheiros áudio em discos CD-R/RW para uma leitura mais fácil.

REPRODUÇÃO DA CASSETE

1. Ligue a unidade ao premir o BOTÃO DE ALIMENTAÇÃO

ALIMENTAÇÃO



2. Prima o BOTÃO DE FUNÇÃO para selecionar CASSETE.



FUNÇÃO



Ecrã LCD

3. Introduza a cassete.



4. Prima o botão REPRODUZIR

REPRODUZIR



PARA PARAR A REPRODUÇÃO

Prima o botão STOP / BOTÃO DE EJEÇÃO.

PARA COLOCAR A REPRODUÇÃO EM PAUSA

Prima o botão PAUSA.

Para retomar a reprodução, prima o botão PAUSA.

AVANÇAR RÁPIDO

Prima o botão RECUAR ou AVANÇAR. Prima o botão STOP/EJEÇÃO para parar de avançar na posição desejada.

GRAVAÇÃO

UTILIZE CASSETES DE GRAVAÇÃO NORMAIS (TIPO I).

1. Introduza a cassete.



2. Prima o botão PAUSA



3. Prima o botão GRAVAR



4. Prepare para reproduzir a fonte a ser gravada e reproduza-a. Prima o botão FUNÇÃO para selecionar o modo CD ou RÁDIO.

Gravar a partir do CD



REPRODUZIR O CD

Gravar a partir do Rádio



SINTONIZAR UMA
ESTAÇÃO STATION

5. Prima o botão PAUSA



PARAR DE GRAVAR

Prima o botão STOP / BOTÃO DE EJEÇÃO.

INTERROMPER A GRAVAÇÃO

Prima o botão PAUSA.

Para retomar a gravação, prima o botão PAUSA novamente.

APAGAR UMA CASSETE GRAVADA

1. Prima o BOTÃO DE FUNÇÃO para selecionar CASSETE.
2. Introduza uma cassete com o lado que pretende apagar virado para si.
3. Prima o botão GRAVAR para começar a apagar.

MANUTENÇÃO

LIMPAR O CD

Se o CD saltar ou não reproduzir, o disco pode precisar de limpeza. Antes de reproduzir, limpe o disco do centro para fora com um pano. Depois da utilização, guarde o disco na respetiva caixa.



LIMPAR A UNIDADE

Não utilize químicos voláteis nesta unidade. Limpe passando ao de leve com um pano macio.

NOTA IMPORTANTE

Caso ocorra uma anomalia no funcionamento ou uma indicação anómala no ecrã, desligue o cabo de alimentação CA e remova as pilhas. Aguarde pelo menos 5 minutos e volte a ligar o cabo de alimentação CA ou reinstale as pilhas.

LIMPAR ALENTE DO CD

Se a lente do CD tiver pó, limpe-a com uma escova com bomba de ar. Bombeie várias vezes sobre a lente e remova o pó com o pincel. As impressões digitais podem ser removidas com um cotonete humedecido com álcool.

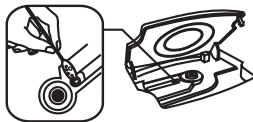

AVISO

Caso a bandeja do CD seja aberta antes de a leitura do CD estar completa, pode ouvir-se um som de obstrução. Esta situação resolve-se fechando a bandeja.

ESPECIFICAÇÕES

SECÇÃO CASSETE

| | |
|--------------------------------------------------------|-----------------------------------|
| Formato da faixa: | 2 faixas stereo |
| Sistema de gravação: | Desvio CA |
| Apagar o sistema: | 6 polos de eliminação magnética |
| Velocidade da cassete: | 4,75 cm / seg. |
| Tempo de F.F. (andar para a frente) e REW (para trás): | 170 seg. (F-60 cassetes) |
| Resposta de frequência: | 125 Hz - 8000 Hz (cassete normal) |

SECÇÃO DO CD

| | |
|-------------------------------------|-------------------------------|
| Canais: | 2 canais |
| Relação sinal/ruído: | 60 dB |
| Wow & Flutter: | indetetável |
| Frequência de amostragem: | 44,1 kHz 8 x sobre amostragem |
| Quantificação: | conversor D/A de 1 bit |
| Fonte de iluminação da lente ótica: | Díodo laser |
| Comprimento de onda | 790 |

SECÇÃO DO RÁDIO

| | |
|-----------------------|---------------------------------------------|
| Banda de frequências: | 87.5 - 108 MHz FM 522 - 1620 kHz AM |
| Antenas: | AM Built - em ferrite Antena de haste FM |

ASPETOS GERAIS

| | |
|-----------------------|-------------------------------------------------------|
| Potência de saída: | 1,2 W + 1,2 W (RMS) |
| Consumo de energia: | 9,5 W |
| Entrada AUX IN | 3,5 W |
| Altifalante: | 3 " 8 OHM |
| Fonte de alimentação: | CA: 230V ~ 50 Hz CC: 9V (6 x 1.5V LR14/ "C"/UM2) |

| | |
|------------|----------------------------|
| Dimensões: | 294(L) x 206(D) x 153(H)mm |
| Peso | 1,72 Kg |

Devido a melhorias contínuas, as funcionalidades e design estão sujeitos a mudança sem aviso.

Onde colocar o objeto:

A mobília de hoje é revista por uma ampla variedade de vernizes e revestimentos sintéticos que são tratados com uma extensa gama de produtos de limpeza. Por esse motivo, não se pode por de parte a possibilidade de algumas dessas substâncias conterem componentes que reajam de forma adversa com as bases de borracha do objeto, amolecendo-as. As bases de borracha do aparelho podem causar descoloração das superfícies dos móveis. Se for necessário, coloque o aparelho sobre uma superfície antiderrapante.

Nota: Para economizar energia, quando ele emite nenhum som por algum tempo, a unidade vai ser interrompida automaticamente. Para reinstalar a operação, basta selecione uma função novamente.

Não deite fora os aparelhos elétricos e eletrônicos juntamente com o lixo doméstico.

- Entregue-os no ponto de recolha.
- Algumas partes destes aparelhos podem ser perigosas para a saúde e para o ambiente.





Fabricado por BIGBEN INTERACTIVE SA
 396, Rue de la Voyette
 CRT2 - FRETIN
 CS 90414
 59814 LESQUIN Cedex - França
www.bigben.eu
 Fabricado na China



bigben

Fabricant : Bigben Interactive FRANCE

396, Rue de la Voyette, C.R.T. 2 Fretin,
 CS 90414 - 59814 LESQUIN Cedex

Bigben Interactive DEUTSCHLAND GmbH

Walter Gropius Str. 28, 50126 Bergheim, Deutschland

Bigben Interactive BELGIUM

Avenue Ernest Solvay, 1480 Tubize, Belgique

Bigben Interactive NEDERLAND b.v.

Franciscusweg 249-3B, 1216 SG Hilversum, Nederland

Bigben Interactive SPAIN S.L.

C/ Musgo 5, 2ª planta, 28023 Madrid, Spain

Bigben Interactive ITALIA s.r.l

Corso Sempione 221, 20025 Legnano - MI, Italia

FABRIQUÉ EN CHINE / MADE IN CHINA

HOTLINE

FRANCE, du lundi au vendredi (sauf jours fériés) :
 9h00-19h00 ou support@thomsonaudiovideo.eu

N°Cristal 09 69 32 59 62

APPEL NON SURTAXE

DEUTSCHLAND, Montag bis Sonntag von 8:00 bis 24:00 Uhr
 09001-84 30 44* (0,49€/Min. aus dem deutschen Festnetz, Anrufe aus allen

Mobilfunknetzen nicht möglich) oder support@bigben-interactive.de

*Minderjährige müssen vorher einen Erziehungsberechtigten um Erlaubnis fragen.

BELGIQUE / NEDERLAND, klantenservice@bigben-interactive.nl
customerservice@bigben-interactive.be

ESPAÑA, sat@bigbeninteractive.es

ITALIA, support@bigbeninteractive.it

www.bigben.eu

THOMSON é uma marca registada da TECHNICOLOR SA ou das suas filiais sob
 licença da Bigben Interactive.

PT-10



THOMSON

RK200CD

TRAGBARER CD-PLAYER MIT RADIO UND KASSETTENRECORDER



BEDIENUNGSANLEITUNG

**BITTE LESEN SIE DIESE BETRIEBSANLEITUNG VOR GEBRAUCH
DES PRODUKTES SORGFÄLTIG DURCH UND BEWAHREN SIE SIE
ANSCHLIEßEND ZU NACHSCHLAGEZWECKEN AUF.**

WARNUNG

LASERPRODUKT DER KLASSE 1

CLASS 1 LASER PRODUCT
APPAREIL À LASER DE CLASSE 1
PRODUCTO LASER DE CLASE 1

VORSICHT
UNSICHTBARER LASERSTRAHL BEI
ÖFFNUNG DES GERÄTES UND BEI
ÜBERWINDUNG DER
SICHERHEITSSPERREN.



Dieses Produkt enthält einen Niederstromlaser.

Warnung: Linse nicht berühren.

BATTERIEN NICHT IN OFFENES FEUER WERFEN!

VORSICHTSMASSNAHMEN

Bitte beachten Sie die folgenden Anweisungen, um einen sicheren und ordnungsgemäßen Betrieb zu gewährleisten.

HINWEISE ZUR AUFSTELLUNG

- Benutzen Sie das Gerät nicht an extrem heißen, kalten, staubigen oder feuchten Stellen.
- Stellen Sie das Gerät auf eine flache und ebene Fläche.
- Behindern Sie die Belüftung des Gerätes nicht, etwa indem Sie das Gerät an einer schlecht belüfteten Stelle aufstellen, mit einem Tuch bedecken oder auf einen Teppich stellen.

SICHERHEIT

- Ziehen Sie bei Trennung des Stromkabels vom Stromnetz ausschließlich am Stecker und nicht am Kabel selbst. Wenn am Kabel gezogen wird, könnte das Kabel beschädigt werden und eine Stromstoßgefahr darstellen.
- Wenn Sie das Gerät über einen längeren Zeitraum nicht verwenden möchten, trennen Sie das Netzkabel vom Stromnetz.

WECHSELSPANNUNG

- Prüfen Sie vor der Inbetriebnahme, ob die Netzspannung des Gerätes mit der Spannung Ihres örtlichen Stromnetzes übereinstimmt.

KONDENSWASSERBILDUNG

- Wenn sich das Gerät in einem beheizten Zimmer mit warmem und feuchtem Raumklima befindet, kann sich Kondenswasser im Inneren des CD-Players bilden.
- Bei einer solchen Kondenswasserbildung funktioniert das Gerät möglicherweise nicht ordnungsgemäß.
- Lassen Sie es 1 bis 2 Stunden lang stehen, bevor Sie es einschalten, oder heizen Sie das Zimmer nach und nach auf und trocknen Sie das Gerät vor dem Einschalten.
- Achten Sie auf einen Mindestabstand von 5 cm um das Gerät herum für eine ausreichende Belüftung.
- Stellen Sie sicher, dass die Belüftung nicht durch Abdecken der Belüftungöffnungen mit Gegenständen wie Zeitungen, Tischtüchern, Vorhängen etc. behindert wird.
- Stellen Sie keine Gegenstände, die offene Flammen absondern können (z. B. brennende Kerzen), auf das Gerät.
- Bitte entsorgen Sie Batterien umweltgerecht.
- Benutzen Sie das Gerät ausschließlich in gemäßigtem Klima.
- Setzen Sie das Gerät keinem Tropf- oder Spritzwasser aus.
- Stellen Sie keine mit Flüssigkeit gefüllten Gegenstände (z. B. Vasen) auf das Gerät.
- Batterien sollten keiner übermäßigen Hitze (Sonnenlicht, Feuer o. ä.) ausgesetzt werden.
- Der Netzstecker des Gerätes darf nicht versperrt werden und muss während der Benutzung des Gerätes leicht zugänglich bleiben.

Trennen Sie das Gerät bei eventuellen Problemen vom Stromnetz und wenden Sie sich an qualifiziertes Fachpersonal.



Das Dreieckssymbol mit dem Pfeilblitz ist ein Warnzeichen, das den Benutzer vor gefährlicher Spannung im Inneren des Gerätes warnt.

VORSICHT
STROMSTOSSGEFAHR
NICHT ÖFFNEN

ACHTUNG : Um Stromstöße zu vermeiden, darf das Gehäuse nicht geöffnet werden. Im Inneren des Gerätes befinden sich keine Teile, die von Endnutzern repariert werden können. Bitte wenden Sie sich an qualifiziertes Fachpersonal.





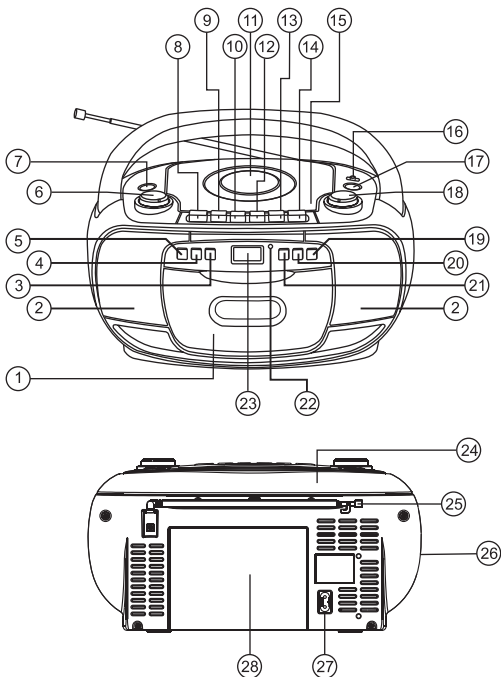

Das Dreieckssymbol mit dem Ausrufezeichen ist ein Warnzeichen, das den Benutzer auf wichtige Anweisungen, die zum Produkt gehören, hinweist.

Im Falle einer Fehlfunktion aufgrund elektrostatischer Entladung muss das Gerät auf die Werkseinstellungen zurückgesetzt werden, indem Sie es vom Stromnetz trennen.

DIE KENNZEICHNUNG BEFINDET SICH AN DER RÜCKSEITE DES GERÄTES.



- | | |
|-------------------------------------------------------------------------------------------------------------------------|-------------------------------------------------------------------------------------------------------------|
| 1. KASSETTENFACH | 15. CD-AUSWURFTASTE |
| 2. LAUSPRECHER | 16. WELLENBEREICHSSCHALTER |
| 3. CD BACK-TASTE  | 17. FUNCTION-TASTE |
| 4. CD STOP-TASTE  | 18. SENDERWAHL |
| 5. CD PROGRAM/CLOCK-ADJ.-TASTE | 19. CD PLAY MODE-TASTE |
| 6. LAUTSTÄRKENREGLER | 20. CD NEXT-TASTE  |
| 7. POWER-TASTE  | 21. CD PLAY/PAUSE-TASTE  |
| 8. PAUSE-TASTE (KASSETTENTEIL)  | 22. FM-STEREO LED-ANZEIGE |
| 9. STOP/EJECT-TASTE (KASSETTENTEIL)  | 23. LCD-DISPLAY |
| 10. F.FWD-TASTE (KASSETTENTEIL)  | 24. TRAGEGRIF |
| 11. CD-FACH | 25. TELESKOPANTENNE |
| 12. REWIND-TASTE (KASSETTENTEIL)  | 26. AUX-EINGANG: WEG |
| 13. WIEDERGABE (KASSETTENTEIL)  | 27. NETZKABELANSCHLUSS |
| 14. AUFNAHME (KASSETTENTEIL)  | 28. BATTERIEFACH |

STROMVERSORGUNG

VERWENDUNG VON NETZSTROM

Prüfen Sie vor der Inbetriebnahme, ob die Netzspannung des Gerätes mit der Spannung Ihres örtlichen Stromnetzes übereinstimmt.

Hinweis: Der Netzstecker dient zur Trennung des Gerätes vom Stromnetz. Der Netzstecker muss frei zugänglich bleiben.

VERWENDUNG VON BATTERIEN

Trennen Sie das Stromkabel von dem Netzkabelanschluss am Gerät. Die Stromversorgung mit Batterien wird bei Anschluss des Netzkabels automatisch unterbrochen.

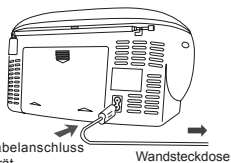
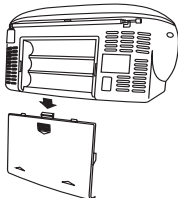

Wenn die Lautstärke schwindet und sich der Klang verzerrt, müssen sämtliche Batterien durch neue ersetzt werden.

Legen Sie 6 UM-2-Batterien (Größe C) ein.

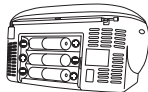

EIN- BZW. AUSSCHALTEN DES GERÄTES

Betätigen Sie die POWER-Taste , um das Gerät einzuschalten.

Zum Wechseln zwischen CD-, RADIO- oder AUX-Wiedergabe betätigen Sie die FUNCTION-Taste bei eingeschaltetem Gerät.

Der Wiedergabemodus wird angezeigt.

Schalten Sie das Gerät durch Betätigung der POWER-Taste  aus.

Der Schriftzug OFF erscheint kurz auf dem Display. Im Anschluss daran wird wieder die aktuelle Uhrzeit angezeigt.

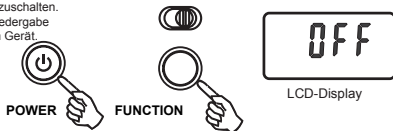

AUX. IN

Eine externe Audioquelle (z. B. tragbarer CD-Player oder MP3-Player) kann an diese Anlage angeschlossen werden und die Wiedergabe kann über die Lautsprecher erfolgen.

- 1) Plug one end of cable into the AUX IN socket on the unit.
- 2) Plug the other end of the cable into the Headphone or Line Out socket of the external source.
- 3) Press the FUNCTION button to select AUX.

Bedienen Sie den externen CD-Player bzw. MP3-Player wie gewohnt. Die Wiedergabe wird über die Lautsprecher Ihrer Mini-Stereoanlage erfolgen.

Das Gerät wird sich nach 4,5 Stunden ohne jegliche Bedienung automatisch abschalten.

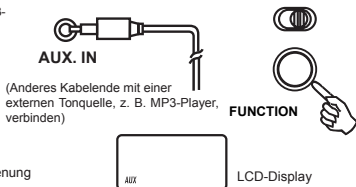

KLANGEINSTELLUNG

LAUTSTÄRKENEINSTELLUNG

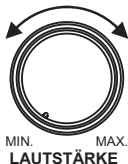

UHRZEITEINSTELLUNG

Die Uhr wird im LCD-Display angezeigt, wenn sich das Gerät im Standby-Modus befindet.

1. Betätigen Sie die PROGRAM / CLOCK-ADJ-Taste und halten Sie sie gedrückt.
2. Betätigen Sie die NEXT ►► - bzw. BACK ◄◄ -Taste, um zwischen 12- und 24-Stunden-Anzeige zu wählen.
3. Betätigen Sie die PROGRAM / CLOCK-ADJ-Taste. Die Ziffern für die Stunde werden aufblincken.
4. Betätigen Sie die NEXT ►► - bzw. BACK ◄◄ -Taste zur Einstellung der Stunde.
5. Betätigen Sie die PROGRAM / CLOCK-ADJ-Taste. Die Ziffern für die Minute werden aufblincken.
6. Betätigen Sie die NEXT ►► - bzw. BACK ◄◄ -Taste zur Einstellung der Minute.



RADIOEMPFANG

1. Schalten Sie das Gerät durch Betätigung der POWER-Taste  ein.



2. Betätigen Sie die FUNCTION-Taste, um zum Radiobetrieb zu wechseln.

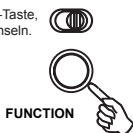
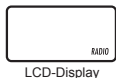

3. Wählen Sie einen Wellenbereich.

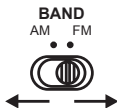

ZUR VERBESSERUNG DER EMPFANGSQUALITÄT

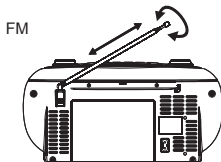

4. Stimmen Sie auf einen Sender ab.

SENDERWAHL

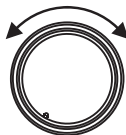

5. Klangeinstellung.

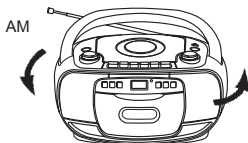

CD-WIEDERGABE

Schalten Sie das Gerät durch Betätigung der POWER -Taste aus.

CD-WIEDERGABE

1. Schalten Sie das Gerät durch Betätigung der POWER-Taste  ein.



2. Betätigen Sie die FUNCTION-Taste, um die CD-Wiedergabe auszuwählen. Das Symbol "  " blinkt auf und das System sucht nach einer eingelegten CD.

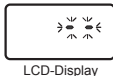

FUNCTION



3. Öffnen Sie das CD-Fach durch Betätigung der Open/Close CD-Taste.



4. Legen Sie eine CD mit der bedruckten Seite nach oben ein.



5. Schließen Sie das CD-Fach. Die CD wird rotieren und die Gesamtzahl der Titel auf der CD wird im Display angezeigt.

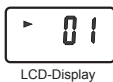

6. Betätigen Sie die PLAY/PAUSE-Taste  . Die Titelnnummer 01 und das Symbol "  " werden angezeigt.



UNTERBRECHUNG DER WIEDERGABE

Betätigen Sie die PLAY/PAUSE-Taste  . Das Symbol "  " wird aufblinken. Betätigen Sie die Taste erneut, um die Wiedergabe fortzusetzen.







BEENDIGUNG DER WIEDERGABE



Betätigen Sie die STOP-Taste  . Das Display zeigt nun die Gesamtzahl der Titel an.



ZUM ANFANG EINES TITELS SPRINGEN

- Betätigen Sie die  - bzw.  -Taste je nach gewünschter Suchrichtung.
- Die Wiedergabe wird mit dem gewünschten Titel fortgesetzt.
- Wenn die  -Taste einmal kurz während der Wiedergabe betätigt wurde, wird der vorherige Titel erneut abgespielt.
- Wenn die  -Taste einmal während der Wiedergabe betätigt wurde, wird der nächste Titel abgespielt.

EINE BESTIMMTE PASSAGE INNERHALB EINES TITELS SUCHEN

- Halten Sie die  - bzw.  -Taste während der Wiedergabe gedrückt und lassen Sie sie los, wenn Sie die gewünschte Passage erkennen. Daraufhin wird die normale CD-Wiedergabe an dieser Stelle fortgesetzt.



Das Gerät wird sich nach 30 Minuten ohne jeglichen Betrieb (im Stop-Modus/bei geöffnetem CD-Fach) automatisch abschalten.

REPEAT , REPEAT ALL UND MIX

Betätigen Sie die Taste PLAY MODE, während sich das Gerät nicht im Wiedergabe-Modus befindet. Die CD kann mit einfacher Titelwiederholung, mit Wiederholung sämtlicher Titel oder mit Zufallswiedergabe abgespielt werden.

WIEDERGABEMODUS



NORMALE CD-WIEDERGABE

Wiedergabemodus-Reihenfolge REPEAT >> REPEAT ALL >> MIX >> NORMAL.

Im Repeat 1-Modus zeigt das Display



Im Mix-Modus zeigt das Display



LCD-Display

Im Repeat 2-Modus zeigt das Display



LCD-Display

PROGRAMMIERTE WIEDERGABE

Die programmierte Wiedergabe ermöglicht die Wiedergabe von Titeln in einer selbst gewählten Reihenfolge. Bis zu 20 Titel können programmiert werden.

1. Betätigen Sie die PROGRAM-Taste.
2. Betätigen Sie die "NEXT"- bzw. "BACK"-Taste, um die gewünschte Titelnnummer zu wählen.
3. Betätigen Sie die PROGRAM-Taste erneut, um den Titel zu speichern.
4. Wiederholen Sie die Schritte 2 und 3, bis alle Titel in der gewünschten Reihenfolge programmiert sind.
5. Betätigen Sie die PLAY/PAUSE -Taste, um die Wiedergabe zu starten. "▶" Das CD-Display zeigt "PROG" und die Titelnnummer an.
6. Zur Beendigung der programmierten Wiedergabe betätigen Sie einmalig die STOP-Taste.

7. Betätigen Sie die PLAY/PAUSE-Taste, um die programmierte Wiedergabe fortzusetzen.
8. Öffnen Sie das CD-Fach, schalten Sie den CD-Player aus oder betätigen Sie die STOP-Taste zweimal, um den Programmspeicher zu löschen.

Anmerkung: Eine Programmierung kann nur vorgenommen werden, wenn sich der CD-Player im Stop-Modus befindet.



LCD-Display

Hinweis zum Abspielen von CD-R/RW

- Da CD-R/RW-Discs keinen festen Format- und Produktionsstandards unterliegen, können die Qualität und die Möglichkeit der Wiedergabe nicht garantiert werden.
- Der Hersteller ist nicht haftbar für die Abspielbarkeit von CD-R/RW-Discs, da diese von einer Vielzahl von Faktoren abhängig ist, wie z. B. PC-Leistung, Brennsoftware, Tauglichkeit des Datenträgers etc.
- Kleben Sie auf keine der Seiten einer CD-R/RW ein Etikett auf. Dies könnte zu Fehlfunktionen führen.
- Um die Wiedergabe einer CD-R/RW zu erleichtern, sollte diese nur Audio-Dateien enthalten.

KASSETTENWIEDERGABE

1. Schalten Sie das Gerät durch Betätigung der POWER-Taste ein.



POWER

2. Betätigen Sie die FUNCTION-Taste, um die Kassettenwiedergabe zu



FUNCTION



LCD-Display

3. Legen Sie die Kassette ein.



4. Betätigen Sie die PLAY-Taste .



WIEDERGABE

BEENDIGUNG DER WIEDERGABE

Betätigen Sie die STOP/EJECT-Taste.

UNTERBRECHUNG DER WIEDERGABE

Betätigen Sie die PAUSE-Taste.

Betätigen Sie die PAUSE-Taste erneut, um die Wiedergabe fortzusetzen.

AUFNAHME

BENUTZEN SIE AUSSCHLIESSLICH NORMALBAND (TYPE I) ZUR AUFNAHME.

1. Legen Sie eine Kassette ein.



2. Betätigen Sie die PAUSE-Taste **||**.



3. Betätigen Sie die RECORD-Taste **●**.



4. Bereiten Sie die Tonquelle, von der Sie aufnehmen vor und starten Sie die Wiedergabe. Betätigen Sie die FUNCTION-Taste, um die Funktion CD oder Radio auszuwählen.

ZUM SCHNELLEN VOR- UND ZURÜCKSPULEN

Betätigen Sie die F.FWD- bzw. die REWIND-Taste.

Betätigen Sie die STOP/EJECT-Taste, um das Vor- bzw.

Zurückspulen an der gewünschten Position zu beenden.

Aufnahme einer CD



STARTEN SIE DIE
CD-WIEDERGABE

Aufnahme vom Radio



STIMMEN SIE AUF
EINEN SENDE AB

5. Betätigen Sie die PAUSE-Taste **||**.



BEENDIGUNG DER AUFNAHME

Betätigen Sie die STOP/EJECT-Taste.

UNTERBRECHUNG DER AUFNAHME

Betätigen Sie die PAUSE-Taste.

Betätigen Sie die PAUSE-Taste erneut, um die Aufnahme fortzusetzen.

LÖSCHEN EINER BESPIELTEN KASSETTE

1. Betätigen Sie die FUNCTION-Taste, um die Kassettenwiedergabe zu wählen.
2. Legen Sie eine Kassette so ein, dass die zu löschende Seite Ihnen zugewandt ist.
3. Betätigen Sie die RECORD-Taste, um den Löschvorgang zu starten.

WARTUNG UND PFLEGE

CDs REINIGEN

Wenn eine CD springt oder nicht abgespielt werden kann, könnte die CD reinigungsbedürftig sein. Wischen Sie die CD vor dem Abspielen von der Mitte aus mit einem Reinigungstuch ab. Legen Sie die CD nach dem Abspielen wieder in ihre Hülle.



REINIGUNG DES GERÄTES

Benutzen Sie zur Reinigung dieses Gerätes keine aggressiven Chemikalien. Reinigen Sie das Gerät vorsichtig mit einem weichen Tuch.

WICHTIGER HINWEIS

Bei einer abnormalen Display-Anzeige oder einem anderen Betriebsproblem sollten das Netzkabel abgeklemmt und die Batterien entfernt werden. Warten Sie mindestens 5 Minuten lang, bevor Sie das Netzkabel wieder anschließen und die Batterien einlegen.

REINIGUNG DER CD-LINSE

Wenn die CD-Linse staubig ist, kann sie mit einer Luftbürste gereinigt werden. Geben Sie mehrmals Luft auf die Linse und entfernen Sie den Staub mit der Bürste. Fingerabdrücke können mit einem alkoholgetränkten Baumwoll-Lappen entfernt werden.

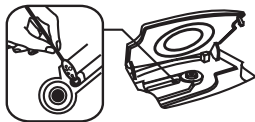

WARNUNG

Bei Öffnung des CD-Faches noch vor Beendigung des Lesevorgangs könnte ein abnormales Geräusch ertönen. Dies lässt sich durch Schließen des CD-Faches beenden.

KASSETTENTEIL

| | |
|----------------------|---------------------------------|
| Spurenformat: | 2-Spur-Stereo |
| Aufnahmesystem: | AC bias |
| Löschkopf: | Magnetischer Löschkopf, 6-polig |
| Bandgeschwindigkeit: | 4.75 cm / Sek. |
| F.F. & REW-Zeit: | 170 Sek. (F-60 Kassetten) |
| Frequenzbereich: | 125 Hz - 8000 Hz (Normalband) |

CD-TEIL

| | |
|---------------------------|--------------------------------|
| Kanäle: | 2 Kanäle |
| Signal-Rausch-Verhältnis: | 60 dB |
| Gleichlaufschwankungen: | nicht feststellbar |
| Abtastfrequenz: | 44,1 kHz 8-faches Oversampling |
| Quantisierung: | 1 bit DA-Converter |
| Lichtquelle: | Halbleiterlaser |
| Laser-Wellenlänge: | 790 nm |

RADIOTEIL

| | |
|-------------------|-----------------------------------------------|
| Frequenzbereiche: | FM 87.5 - 108 MHz AM 522 - 1620 kHz |
| Antennen: | AM: Eingebauter Ferritstab FM: Wurfantenne |

ALLGEMEINES

| | |
|--------------------|-------------------------------------------------------------------------|
| Ausgangsleistung: | 1.2 W + 1.2 W (RMS) |
| Leistungsaufnahme: | 9,5 W |
| AUX IN-Eingang | 3,5 mm |
| Lautsprecher: | 3 " 8 OHM |
| Stromversorgung: | Wechselstrom: 230V ~ 50Hz Gleichstrom: 9V (6 x 1.5V LR14/ "C"/UM2) |

| | |
|--------------|----------------------------|
| Abmessungen: | 294(L) x 206(T) x 153(H)mm |
| Gewicht | 1.72 KG |

Aufgrund der fortschreitenden technischen Entwicklungen können sich die Funktionen und das Design ohne jegliche Vorankündigung ändern.

Aufstellung des Gerätes:

Möbiliar ist heutzutage oft mit einer Vielzahl von Lacken und Synthetikbelägen beschichtet, die mit einer Vielzahl von Reinigungsprodukten behandelt werden müssen. Es ist daher nicht völlig auszuschließen, dass einige dieser Substanzen Bestandteile enthalten, die die Gummi-Standfüße des Gerätes angreifen und weich machen. Auch können die Gummi-Standfüße des Gerätes Verfärbungen an den Möbeln verursachen. Setzen Sie das Gerät ggf. auf eine rutschfeste Oberfläche.

Hinweis: Um Strom zu sparen schaltet sich das Gerät automatisch in Bereitschaft zurück. Durch Drücken der Funktionswahltaste kann das Gerät wieder eingeschaltet werden.

Bitte entsorgen Sie elektrische und elektronische Geräte nicht in den Hausmüll.

- Bringen Sie sie zu einer entsprechenden Sammelstelle.
- Einige Komponenten in diesen Geräten können gesundheits- und umweltschädlich sein.



Hergestellt von BIGBEN INTERACTIVE SA
396, Rue de la Voyette
CRT2 - FRETIN
CS 90414
59814 LESQUIN Cedex - Frankreich
www.bigben.eu
Hergestellt in China



bigben

Fabricant : Bigben Interactive FRANCE

396, Rue de la Voyette, C.R.T. 2 Fretin,
CS 90414 - 59814 LESQUIN Cedex

Bigben Interactive DEUTSCHLAND GmbH

Walter Gropius Str. 28, 50126 Bergheim, Deutschland

Bigben Interactive BELGIUM

Avenue Ernest Solvay, 1480 Tubize, Belgique

Bigben Interactive NEDERLAND b.v.

Franciscusweg 249-3B, 1216 SG Hilversum, Nederland

Bigben Interactive SPAIN S.L.

C/ Musgo 5, 2ª planta, 28023 Madrid, Spain

Bigben Interactive ITALIA s.r.l

Corso Sempione 221, 20025 Legnano - MI, Italia

FABRIQUÉ EN CHINE / MADE IN CHINA

HOTLINE

FRANCE, du lundi au vendredi (sauf jours fériés) :
9h00-19h00 ou support@thomsonaudiovideo.eu

▶ N°Cristal 09 69 32 59 62

APPEL NON SURTAXE

DEUTSCHLAND, Montag bis Sonntag von 8:00 bis 24:00 Uhr

09001-84 30 44* (0,49€/Min. aus dem deutschen Festnetz, Anrufe aus allen
Mobilfunknetzen nicht möglich) oder support@bigben-interactive.de

*Minderjährige müssen vorher einen Erziehungsberechtigten um Erlaubnis fragen.

**BELGIQUE/ NEDERLAND, klantenservice@bigben-interactive.nl
customerservice@bigben-interactive.be**

ESPAÑA, sat@bigbeninteractive.es

ITALIA, support@bigbeninteractive.it

www.bigben.eu

THOMSON ist eine Marke von TECHNICOLOR SA bzw. von Partnern dieses Unternehmens, die von Bigben Interactive im Rahmen einer Lizenz genutzt wird.

THOMSON

RK200CD

**DRAAGBARE CD-SPELER MET RADIO-
EN CASSETTESPELER**



VEILIGHEIDSIINSTRUCTIES

**LEES DEZE GEBRUIKSAANWIJZING VOLLEDIG DOOR ALVORENS
DEZE EENHEID TE BEDIENEN, EN BEWAAR DIT BOEKJE VOOR UW
ADMINISTRATIE.**



WAARSCHUWING

PRODUCT MET LASER UIT KLASSE 1

CLASS 1 LASER PRODUCT
APPAREIL À LASER DE CLASSE 1
PRODUCTO LASER DE CLASE 1

WAARSCHUWING
BIJ OPENING VAN DE APPARATUUR EN
VERWIJDERING VAN DE VERGRENDELINGEN
KAN SPRAKE ZIJN VAN ONZICHTBARE
LASERSTRALING.
VERMIJD BLOOTSTELLING AAN DE STRAAL



Dit product bevat laserapparatuur met laag vermogen.

Waarschuwing: Raak de lens niet aan.

GOOI BATTERIJEN NIET IN VUUR!

VOORZORGSMAATREGELEN

Volg het advies hieronder voor een veilige en juiste bediening.

PLAATSIJNG

- Gebruik de eenheid niet op plekken die extreem heet, koud, stoffig of vochtig zijn.
- Plaats de eenheid op een plat en vlak oppervlak.
- Hinder de luchtstroom van de eenheid niet door deze op een plek met weinig circulatie te plaatsen, met een kleed te bedekken of op een tapijt te zetten.

VEILIGHEID

- Als u het netsnoer in het stopcontact steekt en uit het stopcontact haalt, moet u de stekker vasthouden en niet het snoer zelf. Als u aan het snoer trekt, kunt u het snoer beschadigen. Dit kan gevaarlijke situaties opleveren.
- Als u de eenheid langere tijd niet gebruikt, haalt u het netsnoer uit het stopcontact.

NETSPANNING

- Controleer vóór gebruik of de nominale spanning van de eenheid overeenkomt met de plaatselijke spanning.

CONDENS

- Als u de cd-speler in een verwarmde, vochtige kamer plaatst, kan er condens ontstaan in de apparatuur.
- Als zich condens in de eenheid bevindt, functioneert deze mogelijk niet goed.
- Laat de apparatuur 1 tot 2 uur staan alvorens u deze inschakelt, of verwarm de kamer geleidelijk en droog de eenheid vóór gebruik.
- Bewaar rond de apparatuur minimaal 5 cm ruimte voor voldoende ventilatie.
- De ventilatie mag niet worden gehinderd door voorwerpen die de ventilatieopeningen bedekken, zoals kranten, tafelkleden, gordijnen, enzovoort.
- Plaats geen open vuur, zoals kaarsen, op de apparatuur.
- Denk bij het weggooien van de batterijen aan het milieu.
- Gebruik de apparatuur alleen in een gematigd klimaat.
- Stel de apparatuur niet bloot aan druppelende of spetterende vloeistoffen.
- Plaats geen voorwerpen op de apparatuur die gevuld zijn met water, zoals vazen.
- De batterij mag niet worden blootgesteld aan overmatige hitte, zoals de zon, vuur, enzovoort.
- De netstekker van het apparaat mag niet worden geblokkeerd en moet eenvoudig toegankelijk zijn tijdens het beoogde gebruik.

Haal bij problemen de stekker uit het stopcontact en laat de apparatuur repareren door gekwalificeerd personeel.



De bliksemschicht met een pijlkop in een driehoek is een waarschuwingssymbool. Het waarschuwt voor "gevaarlijke spanning" in de eenheid.

WAARSCHUWING
KANS OP ELEKTRISCHE SCHOK
NIET OPENEN

LET OP: Om het risico van elektrische schokken te beperken, mag u de behuizing niet verwijderen. In de eenheid bevinden zich geen onderdelen die door de gebruiker kunnen worden gerepareerd. Laat alle reparaties uitvoeren door gekwalificeerd onderhoudspersoneel.



Het uitroepteken in de driehoek is een waarschuwingssymbool. Het wijst de gebruiker op belangrijke instructies met betrekking tot het product.

Bij storingen door elektrostatische ontladingen dient de apparatuur te worden gereset door de stekker uit het stopcontact te halen.

HET TYPEPLAATJE BEVINDT ZICH AAN DE ACHTERZIJDE VAN DE APPARATUUR.



LOCATIE VAN DE BEDIENINGSELEMENTEN

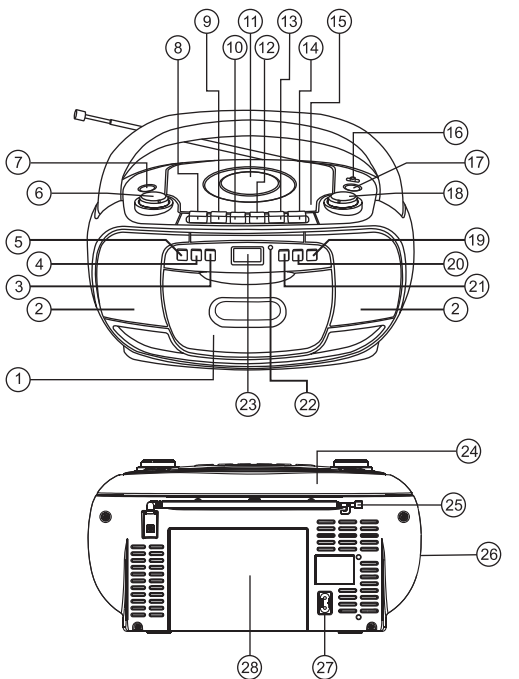

- | | |
|-------------------------------|---------------------------|
| 1. CASSETTEDEUR | 15. OPEN/CLOSE CD-KNOP |
| 2. LUIDSPREKER | 16. BANDSCHAKELAAR |
| 3. CD BACK-KNOP ◀◀ | 17. FUNCTIEKNOP |
| 4. CD STOP-KNOP ■ | 18. AFSTEMREGELING |
| 5. CD PROGRAM/CLOCK-ADJ.-KNOP | 19. CD PLAY MODE-KNOP |
| 6. VOLUMEREGELING | 20. CD NEXT-KNOP ▶▶ |
| 7. AAN/UIT-KNOP ⏻ | 21. CD PLAY/PAUSE-KNOP ▶▶ |
| 8. CASSETTE PAUSE | 22. FM-STEREO-INDICATOR |
| 9. CASSETTE STOP/EJECT ■ ▲ | 23. LCD-SCHERM |
| 10. CASSETTE F.FWD ◀◀ | 24. DRAAGHENDEL |
| 11. CD-DEUR | 25. TELESCOPISCHE ANTENNE |
| 12. CASSETTE REWIND ▶▶ | 26. AUX IN-AANSLUITING |
| 13. CASSETTE PLAY ▶ | 27. STOPCONTACT |
| 14. CASSETTE RECORD ● | 28. BATTERIJCOMPARTIMENT |

VOEDING

GEbruik VAN NETSPANNING

Controleer vóór gebruik of de nominale spanning van de eenheid overeenkomt met de plaatselijke spanning.

Opmerking: De netstekker wordt gebruikt om de eenheid uit te schakelen. De netstekker dient altijd gebruiksklaar te zijn.

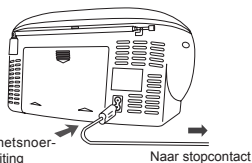

GEbruik VAN BATTERIJEN

Haal het netsnoer uit de netaansluiting van de eenheid. De batterijspanning valt automatisch weg als het snoer is aangesloten.

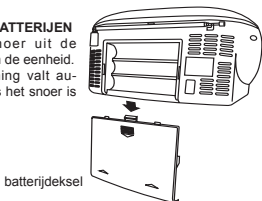

Als het volume lager wordt of het geluid vervormt, vervangt u alle batterijen.

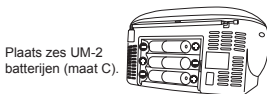

HET SYSTEEM IN-/UITSCHAKELEN

Druk op de AAN/UIT -knop om de audio in te schakelen.

Om de audiomodus te wijzigen in RADIO, AUX, TAPE en CD, drukt u op de FUNCTIE-knop terwijl de eenheid is ingeschakeld.

De audiomodus wordt weergegeven.

Schakel de eenheid uit door op de AAN/UIT -knop te drukken.

Op het scherm worden achtereenvolgens de melding "OFF" en de huidige tijd weergegeven.

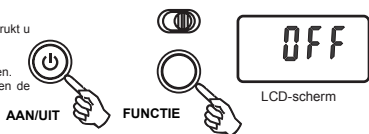

AUX. IN

U kunt op deze eenheid een externe audio(hulp)bron (zoals een eigen cd-speler of mp3-speler) aansluiten en deze via de luidsprekers beluisteren.

- 1) Steek één uiteinde van de kabel in de AUX IN-aansluiting van de eenheid.
- 2) Steek het andere uiteinde van de kabel in de Headphone of Line Out-aansluiting van de externe bron.
- 3) Druk op de FUNCTIE-knop om AUX te selecteren.

Bedien de cd- of mp3-speler op de normale wijze.

U hoort de selectie via de luidsprekers van de eenheid.

Als u de eenheid niet bedient, wordt deze na 4,5 uur automatisch uitgeschakeld.

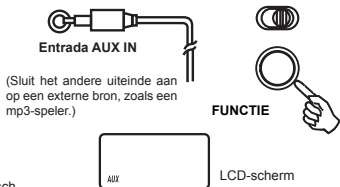

HET GELUID INSTELLEN

HET VOLUME INSTELLEN



KLOK INSTELLEN

In standby-modus wordt op het LCD-scherm een klok weergegeven.

1. Houd de PROGRAM/CLOCK ADJ.-knop vast.
2. Druk op ►►► NEXT of ◀◀◀ BACK om het 12- of 24-uursscherm te selecteren.
3. Als u op de PROGRAM/CLOCK ADJ.-knop drukt, gaan de uren knipperen.
4. Druk op ►►► NEXT of ◀◀◀ BACK om de uren in te stellen.
5. Als u op de PROGRAM/CLOCK ADJ.-knop drukt, gaan de minuten knipperen.
6. Druk op ►►► NEXT of ◀◀◀ BACK om de minuten in te stellen.
7. Als u nogmaals op de PROGRAM/CLOCK ADJ.-knop drukt, wordt de juiste tijd op het scherm weergegeven.



DE RADIO BELUISTEREN

1. Schakel de eenheid in door op de AAN/UIT -knop te drukken.



2. Druk op de FUNCTIE-knop om RADIO te selecteren.

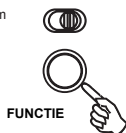
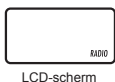

3. Selecteer een frequentieband.



VOOR BETERE ONTVANGST

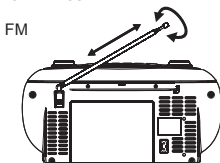

4. Stem af op een zender.

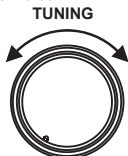

5. Stel het geluid in.

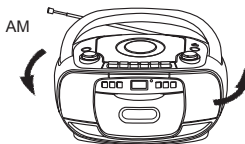
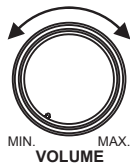

NA HET LUISTEREN

Schakel de eenheid uit door op de AAN/UIT-knop te drukken.

COMPACT DISCS AFSPLENEN

1. Schakel de eenheid in door op de AAN/UIT  -knop te drukken.



2. Druk op de FUNCTIE-knop om CD te selecteren. Het symbool "  " knippert om aan te geven dat de cd-schijf wordt doorzocht.

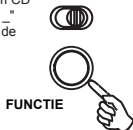
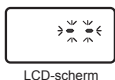



3. Open de cd-deur door op de Open/Close CD-knop te drukken.



4. Plaats een schijf met het etiket omhoog.



5. Sluit de cd-deur.
De schijf gaat draaien en het totaal aantal tracks op de schijf wordt op het scherm weergegeven.

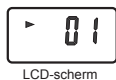

6. Druk op de PLAY/PAUSE  -knop. Het tracknummer "01" en het symbool "  " worden weergegeven.



HET AFSPLENEN ONDERBREKEN

Als u op de Play/Pause  -knop drukt, gaat het symbool "  " knipperen. Druk nogmaals op de knop om het afspelen te hervatten.

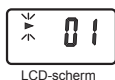

HET AFSPLENEN STOPPEN

Als u op de STOP  -knop drukt, geeft het scherm het totaal aantal tracks op de schijf weer.



OVERSLAAN EN NAAR HET BEGIN VAN EEN TRACK GAAN

- Druk op een van de   skip-knoppen, afhankelijk van de richting waarin u wilt overslaan.
- Het afspelen wordt hervat bij de geselecteerde track.
- Als u tijdens het afspelen eenmaal op de  -knop drukt, begint de vorige track opnieuw.
- Als u tijdens het afspelen eenmaal op de  -knop drukt, wordt de volgende track afgespeeld.

EEN STUK BINNEN EEN TRACK ZOEKEN

- Houd de  of  knop tijdens het afspelen ingedrukt, en laat de knop los zodra u het gewenste stuk heeft gevonden. De normale cd-weergave wordt vanaf dit punt hervat.



Als u de eenheid 30 minuten niet bedient (stopmodus/cd-deur open), wordt deze automatisch uitgeschakeld.

HERHALEN, ALLES HERHALEN EN MIX AFSPLEN

Druk in de stopmodus op de PLAY MODE-knop. U kunt ervoor kiezen om één track op de cd/alle tracks op de cd te herhalen of alle tracks willekeurig af te spelen.

NORMALE WEERGAVE VAN COMPACT DISCS

Modusvolgorde REPEAT >> REPEAT ALL >> MIX >> CLEAR.

In de modus Repeat 1 is het scherm als volgt:



In de modus Repeat 2 is het scherm als volgt:



LCD-scherm

WEERGAVERMODUS

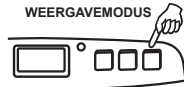

In de mixmodus is het scherm als volgt:



LCD-scherm

GEPROMMEEERDE WEERGAVE

Via de geprogrammeerde weergave kunt u tracks op een schijf in de gewenste volgorde afspelen. U kunt maximaal 20 tracks programmeren.

1. Druk op de PROGRAM-knop.
2. Druk op de NEXT- en BACK-knoppen om het gewenste tracknummer te selecteren.
3. Druk nogmaals op de PROGRAM-knop om de track op te slaan.
4. Herhaal stap 2 en 3 totdat u alle gewenste tracks heeft geprogrammeerd.
5. Druk op de PLAY/PAUSE-knop om te starten. Op het cd-scherm ziet u de melding "►" "PROG" en het tracknummer.
6. Druk eenmaal op de STOP-knop om de geprogrammeerde weergave te stoppen.

7. Druk op de PLAY/PAUSE-knop om de geprogrammeerde weergave te hervatten.
8. Open de cd-deur, schakel de cd-speler uit of druk twee keer op de STOP-knop om het geprogrammeerde geheugen te wissen.

Opmerking: U kunt alleen programmeren in stopmodus.



"PROGRAM"



LCD-scherm

Opmerking over CD-R/RW-schijven

- Omdat het formaat van CD-R/RW's niet is gestandaardiseerd, zijn de afspreekwaliteit en prestaties niet gegarandeerd.
- De fabrikant is niet verantwoordelijk voor het wel of niet kunnen afspelen van CD-R/RW's, de opnamekwaliteit, de prestaties van uw pc, de prestaties van uw schrijfssoftware, de ondersteuning voor bepaalde media, enzovoort.
- Plak geen etiketten op de CD-R/RW-schijf. Dit kan storingen veroorzaken.
- Wij raden u aan om alleen audiobestanden op CD-R/RW-schijven te zetten, om het lezen te vergemakkelijken.

CASSETTES AFSPLEN

1. Schakel de eenheid in door op de AAN/UIT -knop te drukken.



2. Druk op de FUNCTIE-knop om TAPE te selecteren.



LCD-scherm

3. Plaats de cassette.



4. Druk op de  PLAY-knop



HET AFSPLEN STOPPEN

Druk op de STOP/EJECT-knop.

HET AFSPLEN ONDERBREKEN

Druk op de PAUSE-knop.

Om het afspelen te hervatten, drukt u nogmaals op de PAUSE-knop.

VOORUIT- OF TERUGSPOELEN

Druk op de REWIND- of F.FWD-knop.

Druk op de STOP/EJECT-knop om op de gewenste positie te stoppen.

OPNEMEN

GEBRUIK VOOR OPNAMEN ALLEEN NORMAL (TYPE I)-CASSETTES.

1. Plaats de cassetteband.



2. Druk op de PAUSE -knop.



3. Druk op de RECORD -knop.



4. Speel de op te nemen bron af. Druk op de FUNCTIE-knop om CD of RADIO te selecteren.

Opnemen van een CD



SPEEL DE CD AF

Opnemen van de Radio



STEM AF OP EEN STATION

5. Druk op de PAUSE -knop.



DE OPNAME STOPPEN

Druk op de STOP/EJECT-knop.

DE OPNAME ONDERBREKEN

Druk op de PAUSE-knop.

Om de opname te hervatten, drukt u nogmaals op de PAUSE-knop.

EEN OPGENOMEN CASSETTE WISSEN

1. Druk op de FUNCTIE-knop om TAPE te selecteren.
2. Plaats de cassette en richt de te wissen zijde naar u toe.
3. Druk op de RECORD-knop om het wissen te starten.

ONDERHOUD

CD REINIGEN

Als de cd overslaat of niet wil afspelen, moet u deze misschien reinigen. Vóór het afspelen veegt u de schijf vanuit het midden naar buiten af met een reinigungsdoekje. Na het afspelen bewaart u de schijf in een doosje.



DE EENHEID REINIGEN

Gebruik geen vluchtige chemicaliën op deze eenheid. Reinig de apparatuur voorzichtig met een zacht doekje.

BELANGRIJKE OPMERKING

Als er abnormale meldingen op het scherm verschijnen of andere problemen optreden, haalt u de stekker uit het stopcontact en verwijdert u de batterijen. Wacht ten minste 5 seconden en stop de stekker weer in het stopcontact (of installeer de batterijen opnieuw).

DE CD-LENS REINIGEN

Als de cd-lens stoffig is, reinigt u deze met een blaasbalgje. Blaas meerdere keren tegen de lens en verwijder het stof met het borsteltje. Vingerafdrukken kunt u verwijderen met een wattenstaafje dat is bevochtigd met alcohol.

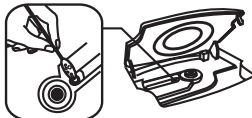

WAARSCHUWING

Als de cd-deur wordt geopend voordat de cd volledig is gelezen, lost u de apparatuur mogelijk vastlopen. U kunt dit oplossen door de cd-deur te sluiten.



SPECIFICATIES

CASSETTESECTIE

| | |
|--------------------|------------------------------------|
| Spoorindeling: | 2-sporen stereo |
| Opnamesysteem: | Voormagnetisering |
| Wissysteem: | Magnetische verwijdering 6 polen |
| Bandsnelheid: | 4,75 cm/sec. |
| F.F.- en REW-tijd: | 170 sec. (F-60-cassettes) |
| Frequentierespons: | 125 Hz - 8000 Hz (Normal-cassette) |

CD-SECTIE

| | |
|---------------------|---------------------------|
| Kanalen: | 2 kanalen |
| S/R-verhouding: | 60 dB |
| Wow en flutter | niet detecteerbaar |
| Samplingfrequentie: | 44,1 kHz 8 x oversampling |
| Kwantisering: | 1-bits DA-converter |
| Lichtbron pick-up: | Halfgeleiderlaser |
| Golfengte pick-up | 790 nm |

RADIOSECTIE

| | |
|-------------------|-----------------------------------------------|
| Frequentiebereik: | FM 87.5 - 108 MHz AM 522 - 1620 kHz |
| Antennes: | Ingebouwde AM-ferrietstaaf FM-staafantenne |

ALGEMEEN

| | |
|---------------------|---------------------------------------------------------------------------|
| Uitgangsvermogen: | 1,2 W + 1,2 W (RMS) |
| Energieverbruik: | 9,5 W |
| Aux In-aansluiting: | 3,5 MM |
| Luidspreker: | 3" 8 OHM |
| Voedingsbron: | Wisselspanning: 230 V ~ 50 Hz Batterijen: 9 V (6 x 1,5 V LR14/"C"/UM2) |
| Afmetingen: | 294 (L) x 206 (D) x 153 (H) mm |
| Gewicht | 1,72 KG |

Vanwege voortdurende productverbeteringen kunnen het ontwerp en de specificaties zonder voorafgaande kennisgeving worden gewijzigd.

Plaatsing van de apparatuur:

Tegenwoordig zijn meubels voorzien van allerlei soorten lakken en synthetische coatings, die op hun beurt weer worden behandeld met talloze reinigingsproducten. Het is daarom niet volledig uit te sluiten dat sommige stoffen een nadelige invloed hebben op de rubberen poten van de apparatuur, waardoor deze verweken. Door de rubberen poten van de apparatuur kan het oppervlak van meubels verkleuren. Eventueel plaatst u de apparatuur op een ruw oppervlak, zodat deze niet kan verschuiven.

Opmerking: om energie te besparen zal de unit op stand-by modus gaan wanneer er geen geluid wordt afgespeeld. De unit kan opnieuw worden aangezet door op de functietoets te drukken.

Gooi elektrische en elektronische apparaten niet in een normale vuilnisbak.

- Breng ze naar een verzamelpunt.
- Sommige onderdelen in deze apparatuur kunnen gevaarlijk zijn voor de gezondheid en het milieu.



Reproduced by BIGBEN INTERACTIVE SA
396, Rue de la Voyette
CRT2 - FRETIN
CS 90414
59814 LESQUIN Cedex - Frankrijk
www.bigben.eu
Gemaakt in China



bigben

Fabricant : Bigben Interactive FRANCE

396, Rue de la Voyette, C.R.T. 2 Fretin,
CS 90414 - 59814 LESQUIN Cedex

Bigben Interactive DEUTSCHLAND GmbH

Walter Gropius Str. 28, 50126 Bergheim, Deutschland

Bigben Interactive BELGIUM

Avenue Ernest Solvay, 1480 Tubize, Belgique

Bigben Interactive NEDERLAND b.v.

Franciscusweg 249-3B, 1216 SG Hilversum, Nederland

Bigben Interactive SPAIN S.L.

C/ Musgo 5, 2ª planta, 28023 Madrid, Spain

Bigben Interactive ITALIA s.r.l

Corso Sempione 221, 20025 Legnano - MI, Italia

FABRIQUÉ EN CHINE / MADE IN CHINA

HOTLINE

FRANCE, du lundi au vendredi (sauf jours fériés) :
9h00-19h00 ou support@thomsonaudiovideo.eu

N°Cristal 09 69 32 59 62

APPEL NON SURTAXE

DEUTSCHLAND, Montag bis Sonntag von 8:00 bis 24:00 Uhr
09001-84 30 44* (0,49€/Min. aus dem deutschen Festnetz, Anrufe aus allen

Mobilfunknetzen nicht möglich) oder support@bigben-interactive.de

*Minderjährige müssen vorher einen Erziehungsberechtigten um Erlaubnis fragen.

BELGIQUE / NEDERLAND, klantenservice@bigben-interactive.nl
customerservice@bigben-interactive.be

ESPAÑA, sat@bigbeninteractive.es

ITALIA, support@bigbeninteractive.it

www.bigben.eu

THOMSON is een handelsmerk van TECHNICOLOR SA of gelieerde bedrijven dat onder licentie wordt gebruikt voor Bigben Interactive.

NL-10



RK200CD-BBI-VER.2