



MN1604

Size: 9V (6LR61)

Alkaline-Manganese Dioxide Battery

Zn/MnO₂



Nominal voltage	9 V
Impedance	1,700 m-ohm @ 1 kHz
Typical weight	46 g (1.7 oz)
Typical volume	22.8 cm ³ (1.4 in ³)
Terminals	Miniature snap
Storage temperature range	5°C to 30°C
Operating temperature range	-18°C to 54°C
Designation	IEC: 6LR61

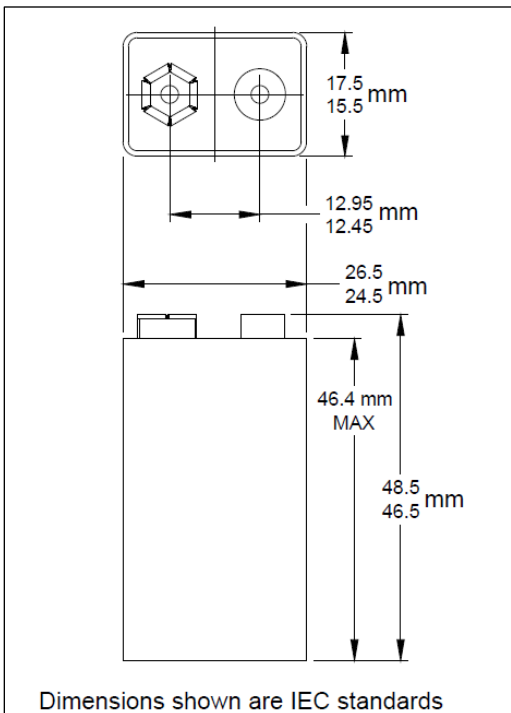

USAGE GUIDE (Please refer to IEC60086.5 for detailed safety and storage specifications.)
(1) Insert batteries correctly with regard to the polarities (“+”/“-”) marked on the battery and the electrical appliances.
(2) Do not short-circuit, recharge, heat, disassemble the battery, or dispose of in fire.
(3) Do not mix use old batteries with new ones, or mix use batteries of different types, chemistries or brands.
(4) Exhausted batteries should be immediately removed from the equipment.
(5) Keep the batteries away from small children. Do not let the child remove/replace batteries without monitoring from adults.
(6) Storage temperature: 5°C~30°C, and humidity conditions RH: 40%~90%.



Berkshire Corporate Park
Bethel, CT. 06801 U.S.A.
Telephone: Toll-free 1-800-544-5454
www.duracell.com

Delivered capacity is dependent on the applied load, operating temperature and cut-off voltage. Please refer to the charts and discharge data shown for examples of the energy/service life that the battery will provide for various load conditions.

