

100" UST ALR Screen

Instruction manual

Table of Contents

- Disclaimer 1
- Copyright 1
- Attention 1
- Warning 2
- Screen Maintenance 2
- Screen Repair 2
- Vision Protection 3
- Cultivation of Good Living Habits 4
- Product Description 4
- Packing List 7
- Screen Assembly 9
- Installation Method 16
- Environmental Statement 20
- Frequently Asked Questions 21

Disclaimer

XGIMI Technology Co.,Ltd does not explicitly or implicitly make any representations or guarantees for the content of this document.

XGIMI Technology Co.,Ltd reserves the rights to revise this publication and modify the content of this document at any time without prior notification.

Please refer to your order requirements for the screen model.

Copyright

The copyright belongs to XGIMI Technology Co.,Ltd.

Without the prior written permission from XGIMI Technology Co.,Ltd, no part of this publication may be copied, transmitted, or transcribed in any form, and no part may be stored in a retrieval system or translated into any language or computer language.

Attention

Thank you for selecting XGIMI 100" UST ALR Screen

This product is made of environmentally-friendly optical materials, with "Fresnel optical structure" as the core, and all Indicators have reached the international advanced level.

The appearance is made of nylon cloth with professionally designed aluminum alloy frame, which makes the screen a work of art in your home.

With Laser (or LED) projector, it is not restricted by the ambient light, allowing you to enjoy the perfect picture quality of home theater at home.

In order to fully understand the characteristics of this product and achieve the best performance, please read this manual carefully before use, and please keep it for future reference.

Warning

Do not place this product on an unstable cart, stand or table. If the product falls to the ground, it may cause serious damage and personal injury.

Do not scratch or touch the screen with hard objects or directly touch the front of the screen with hard objects.

Do not expose the screen to sunlight.

Do not place the screen near flammable, explosive and other dangerous goods.

Screen Maintenance

During use, you can use a dust-free cloth dipped in ethanol to gently wipe the screen and frame, or a dust-free soft cotton cloth to wipe dust and other dirt.

Screen Repair

Please do not try to repair this product by yourself , and please entrust professional technicians to repair it.

Vision Protection

The following suggestions are for your reference:

When you need to watch a program for a long time,
please let your eyes rest frequently

- Let your eyes look outside the monitor frequently , watch a point in the distance , and let your eyes rest.
- Blink frequently to avoid dry eyes.
- Keep the screen clean.
- Reduce glare and reflections:
 - Place the screen with its side facing the window or light source .
 - Use curtains , shutters or blinds to reduce indoor light.
 - Use work lights .
 - Change the screen viewing angle .
 - Use an anti-glare filter .
 - Use a screen hood , such as a decorative plate protruding from the upper end of the screen .
 - Avoid adjusting the screen to a bad viewing angle .

Cultivation of Good Living Habits

- Cultivating the following living habits can make you more relaxed when watching:
- Take regular breaks.
- Do some stretching exercises.
- Breathe fresh air as often as possible.
- Exercise regularly to keep healthy.

Product Description

Characteristics

- Adopt a new generation of Fresnel optical structure design to effectively prevent light interference, and provide 120-inch pure picture to bring shocking visual enjoyment;
- Contain a variety of nano-structure optical layers to significantly enhance the contrast, definition and color expression of the picture and improve the viewing experience;
- The screen is mainly made of environmentally-friendly optical materials, which can ensure the health of you and your family while enjoying the theater-level-audio-visual experience.

Technical Parameters

Category	Screen Model		P165S
	Parameters		
Application	Net Weight		14 Kg
Optical Paramters	Peak Gain		≥1.5
	Gain Uniformity		≥75%
	Ambient Light Occlusion Rate		≥82%
Specification	Image Size	Length	2213mm
		Width	1244 mm
	Screen Size	Length	2245 mm
		Width	1276 mm
	Aspect Ratio		16:9
	Thickness		28.9 mm

*The above are only some of the main product specifications. Please determine the corresponding size according to your order requirements.

*Slight deviation in the size of the screen, if any, is a normal installation and measurement error. Please rest assured to use it.

*The design is subject to any change without prior notice.

Exploded View

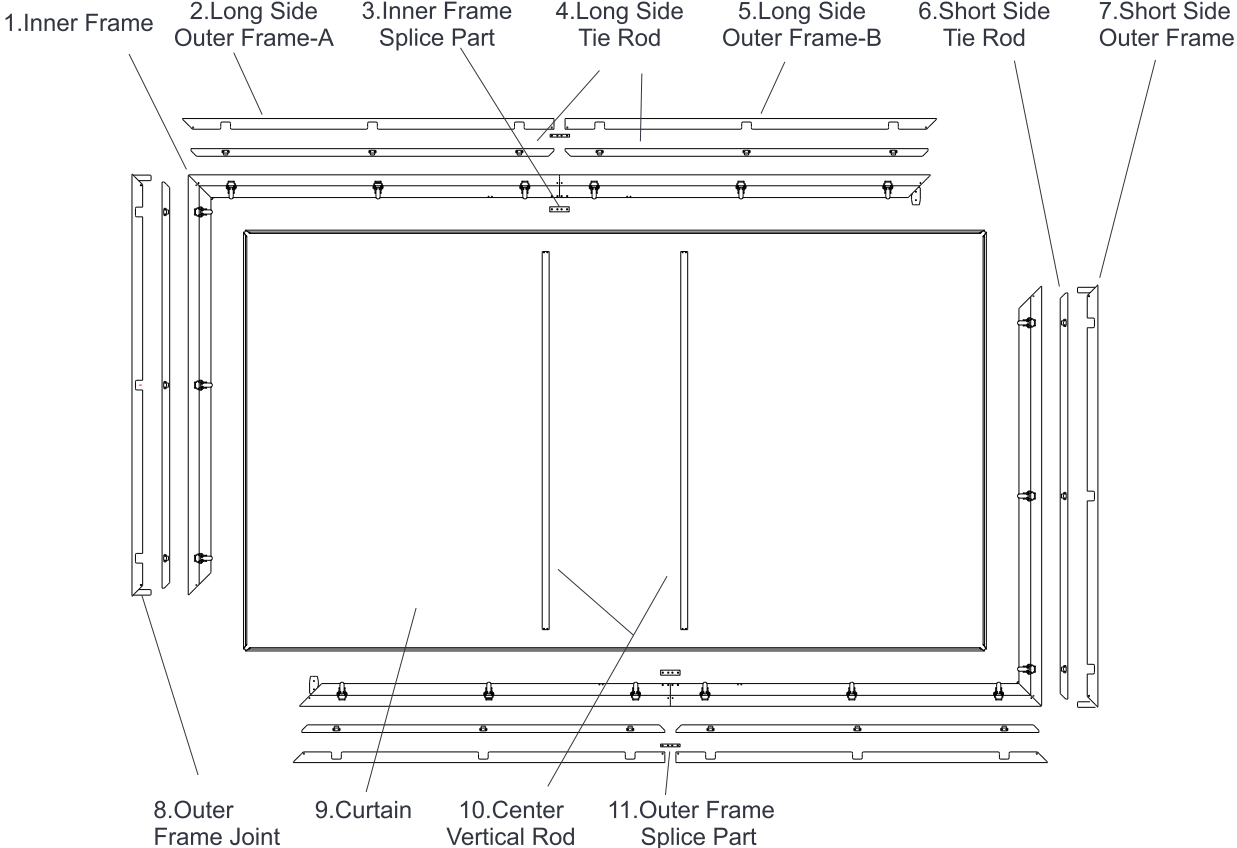

Packing List

The appearance in this manual is only a schematic diagram. You are subject to the purchased goods. After unpacking ,please carefully check the product list.

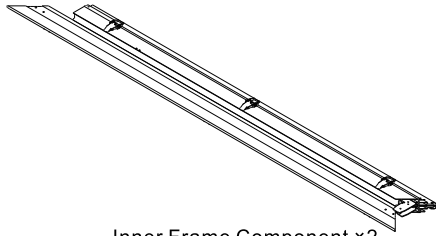

Inner Frame Component x2

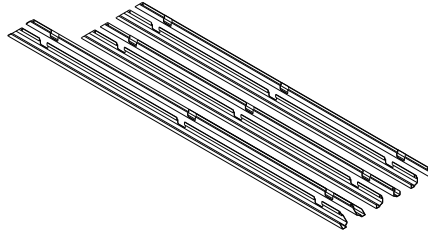

Outer Frame x6

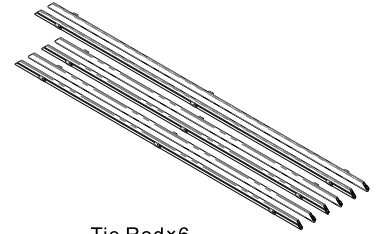

Tie Rod x6

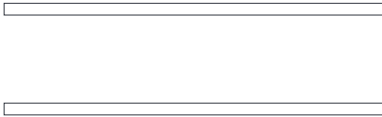

Center Vertical Rod x2



Fiberglass Pole x6

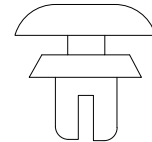

Plastic Rivet x8



Screws M4-16x8
(2Pcs Preinstalled)



Screws M4-8x16
(8Pcs Preinstalled)

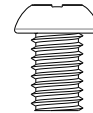

Screws M4-4x44

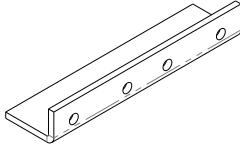

Inner Frame Splicing Parts×2

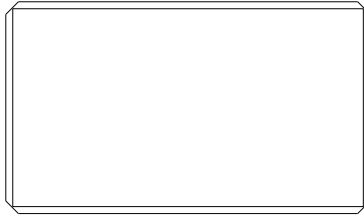

Curtain×1

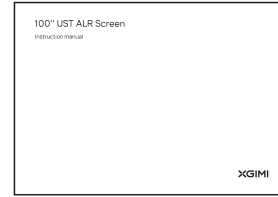

Manual×1



Wall-Mounted Bracket×2

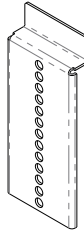

Dust-Free Cloth×1

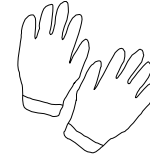

Gloves×2

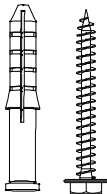

Expansion Screw×6



Alcohol Wipe×1

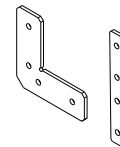

Outer Frame Joint×4
Outer Frame Splice Part×2

Note: The accessories shown in the diagram above may be different from goods you purchased; the product specifications or the contents of the manual may be subject to any change due to the function upgrade of the product without prior notice.

Screen Assembly

Tips : Spread the padding cloth prepared in the packing case on a clean and flat ground, and assemble the inner frame on the padding cloth.

1. Unfold the inner frame component. Take out an inner frame component from the packaging box and pay attention to the orientation of the inner frame placement. After ensuring that the inner frame components are flat, unfold the inner frame as shown in the picture.

(Note : Please do not remove the locking tape.)

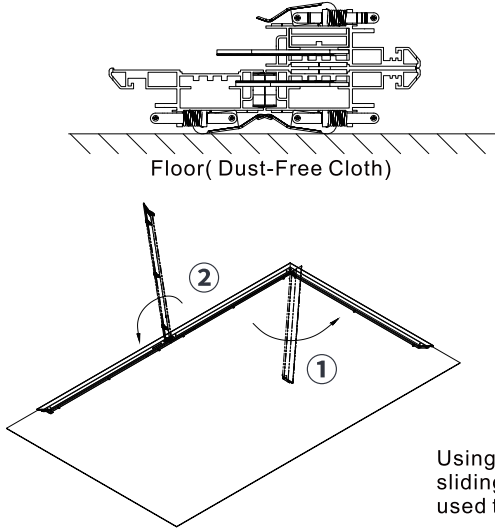

2. Use a screwdriver to loosen the screw on the long hole of the inner frame and slide it to the other end, then tighten it again. Use M4 × 16 screws (longer, silver white) to secure the remaining three threaded holes. Fix the corners of the inner frame with M4 × 8 screws (black, shorter).

Note: When sliding, the frame should be aligned. (roughly flush on both sides)

Please do not completely unscrew the screw.

Use hands to lift the middle seam from the back, adjust the height and up and down directions until the connector slides all the way to the right.

Using M4 × 16 screws. When sliding, a screwdriver can be used to assist.

Using M4 × 8 screws.

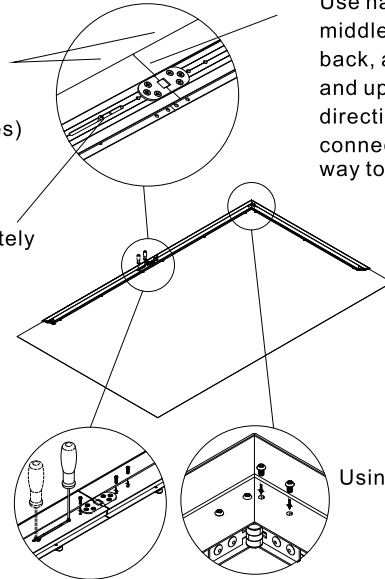

3. Take out another inner frame as the 1-2 step, unfold and fix it.

4. Place the unfolded two inner frame components as shown in the figure. Docking the two components and secure them with M4 × 8 screws (black, shorter).

(Note : When docking, one end of the corner code should be inserted into the corresponding groove of the inner frame first, and then the other end should be inserted. If it is stuck during installation, the frame border position can be adjusted appropriately.)

Fix the screws after installing the corner parts at both ends in place.

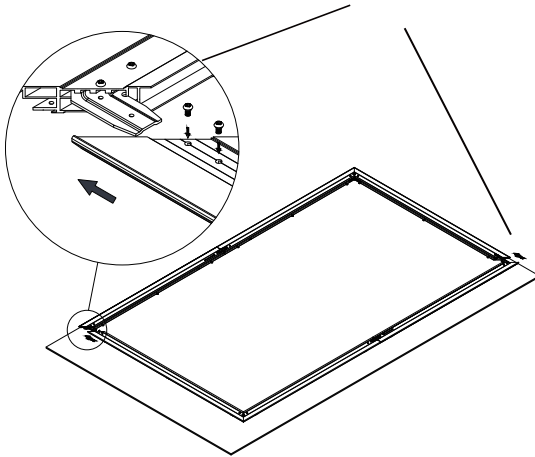

5. After confirming the locking of the screws on the corner code and long hole of the frame, flip the frame so that the side with the locking buckle faces upwards and backwards. Take out the center vertical rod, tilt it and screw it into the installation hole position inside the inner frame. Press the frame tightly and fix the center vertical rod with plastic rivets. (Note : The plastic rivets can be separated first and then tightened.)

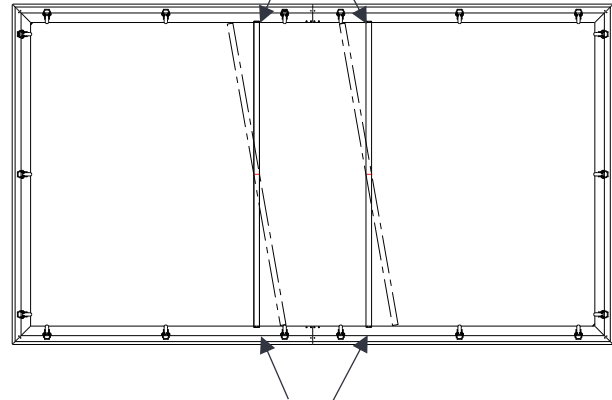
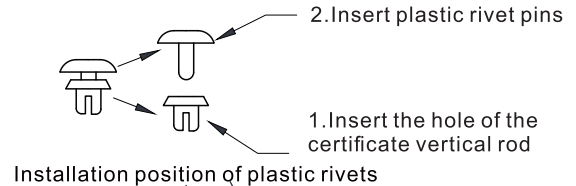

6. Assemble the inner frame splice parts as shown and tighten the screws(M4 × 8)

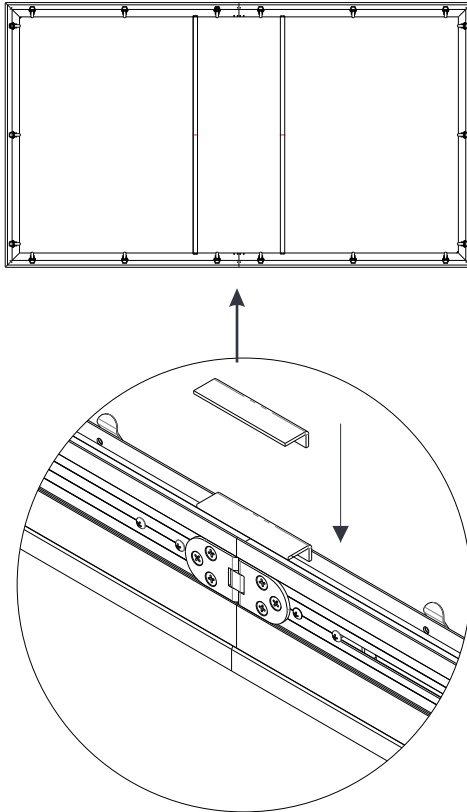

Attention: When lifting the frame, two people should lift it from the short edge of the frame, not from the middle seam of the long edge, or from the middle vertical pole

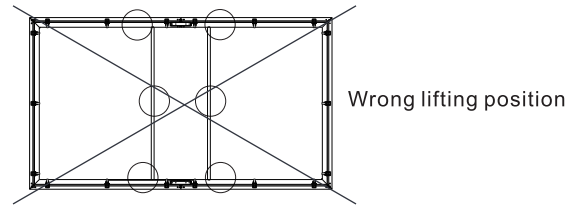
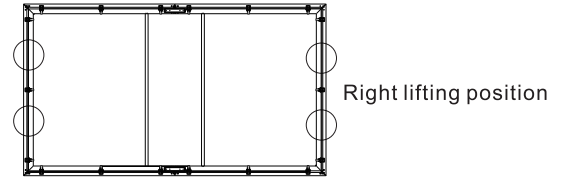

7. Wear gloves and lift the screen out of the packing case by two people.

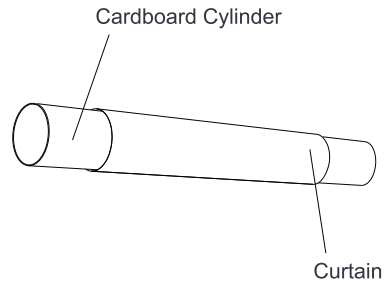

8. Unroll the curtain on the padding cloth and check the screen surface.

(Note : Please do not directly flip or bend the corners, which may bend the curtain surface.)

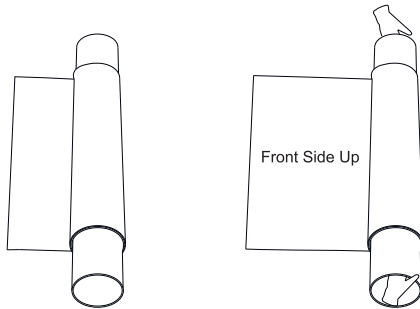

9. Two personnel stand respectively on both sides of the screen width direction, and flip the screen to face down according to the order shown in the diagram.
(Note: Control the magnitude and strength of the action to prevent the screen from bending.)

(1) Two personnel lift the wide edge of the curtain to a certain height.

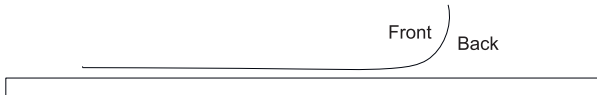

(2) Slowly pull the lifted curtain towards the other side

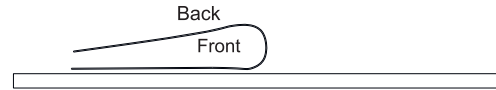

(3) You can hold the curtain with your hands appropriately to prevent it from bending. (Please wear gloves for operation)

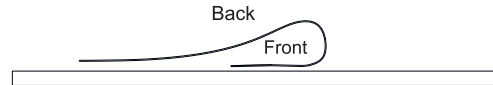

(4) Curtain flip completed



10. Insert the fiberglass rod into the four sides of the curtain, paying attention to distinguishing the long and short sides.

(Note: Two longer fiberglass rods are inserted on both wide sides of the curtain, and four shorter fiberglass rods are inserted on the long side of the screen.)

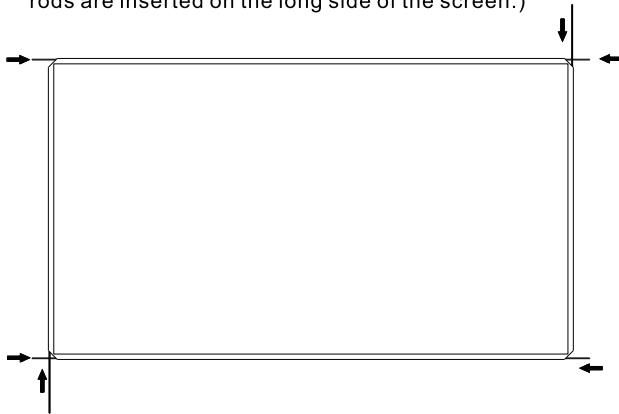

Note:

Please wear gloves for operation.

Before threading the fiberglass rod, remove the leather head from the fiberglass rod.

You can gently press the edge of the cloth from the side and open the cloth Bag.

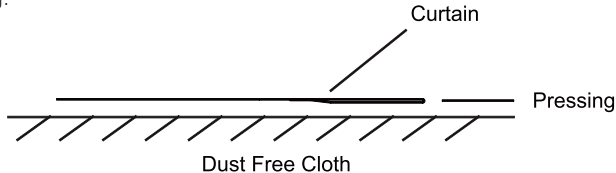

11. Insert the tie rod into the four sides of the curtain, paying attention to distinguishing the front, back, and length of the tie rod.

(Note: Two longer tie rods are threaded on both wide sides of the curtain, and four shorter tie rods are threaded on the long side of the curtain.)

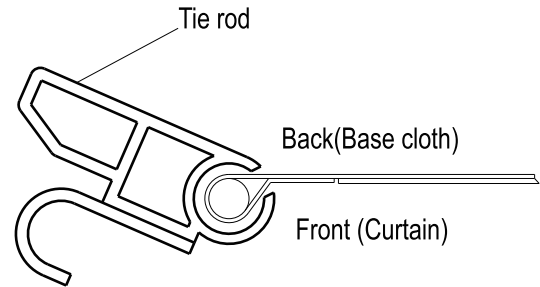

12. Two personnel lift the inner frame horizontally and place it on the screen substrate, adjusting the position of the inner frame to center it.

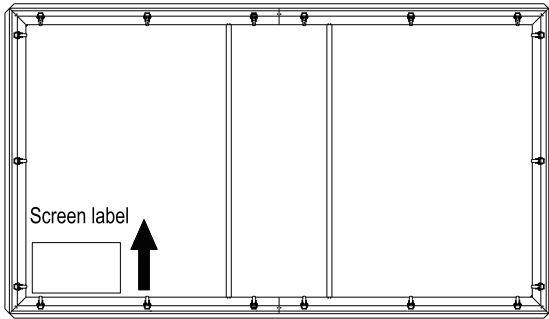

13. Flip the tie rod, adjust the position of the pull rod so that the hook on the pull rod is roughly aligned with the buckle on the inner frame, and hang the buckle on the hook without pressing it tightly. Firstly, flip the tie rod onto the inner frame and then perform the buckle fastening operation; Fasten the buckles on the left and right short side frames, and then fasten the long side buckles. Be careful when pressing down on the buckle, as the buckle may rebound.

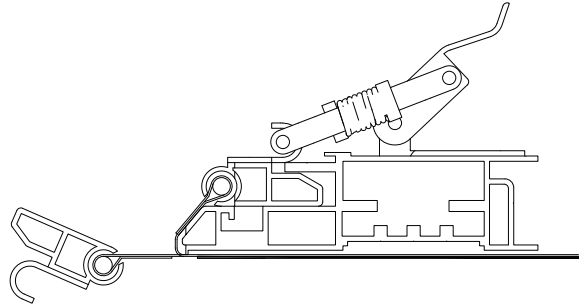

4. Outer frame installation.

First, install the outer frame corner parts and connecting parts on the outer frame as shown in the picture;

Tighten all outer frames onto the inner frame slots without fixing them.

Install the long edge first and then the short edge.

Take out the M4 × 4 screws from the accessory bag and install them in position ① as shown in the diagram (Firstly fix the screws on the four corners, check the seams, and then tighten them.)

Take out the M4 × 4 screws and fix the outer frame at position ② as shown in the diagram.

When installing corner or connecting parts, the screws are temporarily not tightened.

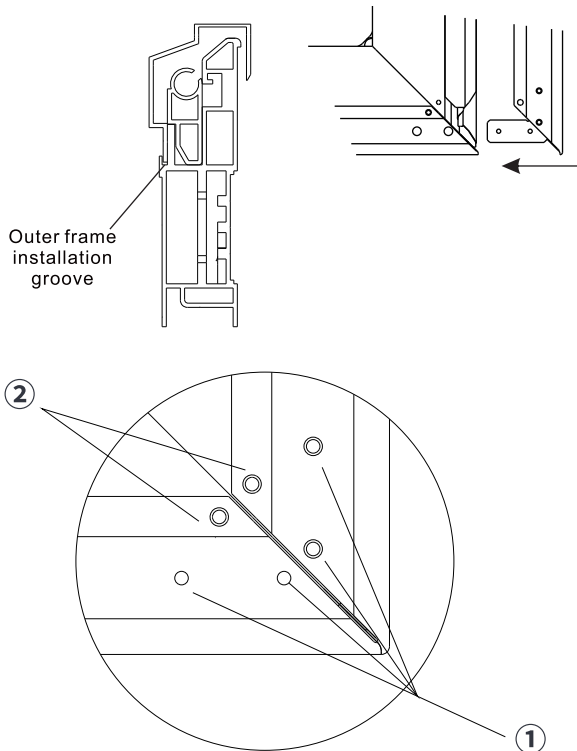
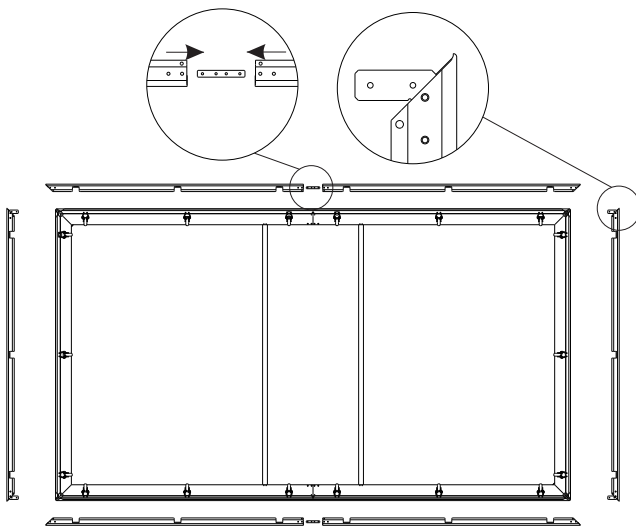

Installation Method

This installation method is only for the installation of the Laser TV screen. Please use this method with the Laser TV installation instructions in the installation process. Before installation, please confirm that the wall can be perforated and the bearing capacity is greater than 50 kg.

1. Project a rectangular image in the center of the installation position, and use a tape measure to determine the length of the bottom edge of the projection image- DL (100": 2213 mm), ensuring that the bottom edge of the image is horizontal (Refer to Ground).

(Refer to P4 "Technical Parameters" for screen size).

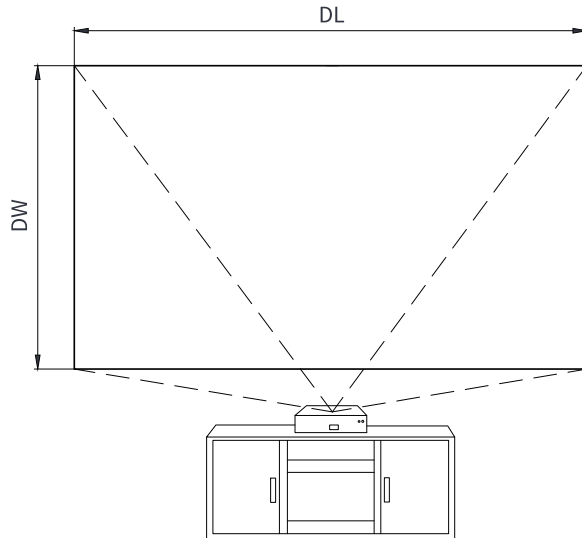

2. Mark the punching points. Take the fixed edge of the projection picture from right to left L1(100": 750 mm) as reference point A1; from which 116 mm vertically down as punching point A2; from which 32 mm vertically down as punching point A3.

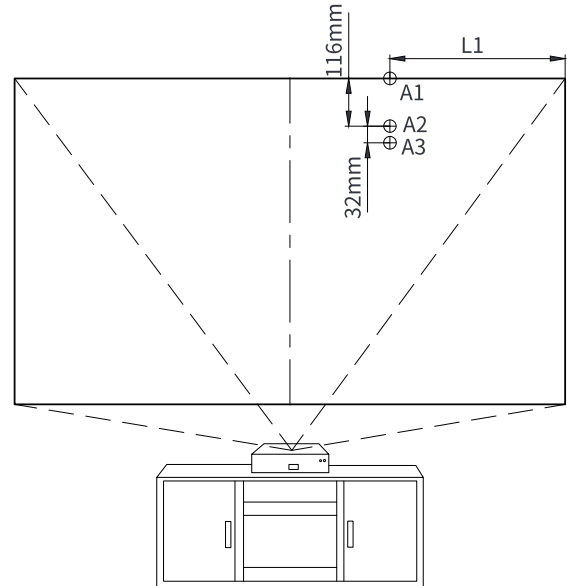

3. Take A2 and A3 as the benchmark, mark B2 and B3 at 713 mm horizontally to the left. (Note that A2, B2, and C2 need to be on the same horizontal line, and so do A3, B3, and C3.)

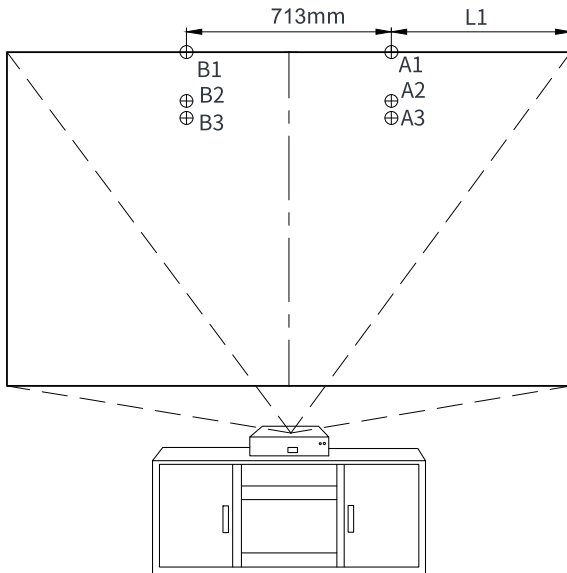

4. Drill holes at 4 punching points with a drill bit diameter of 8 mm and a drilling depth of not less than 65 mm.

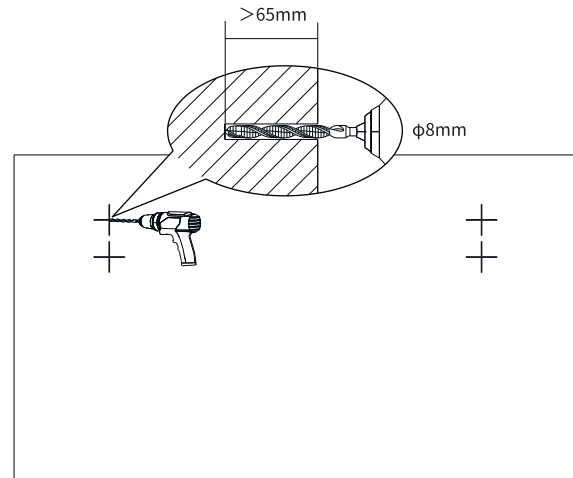

5. Nail the expansion screws into the fifth and ninth holes on the wall.

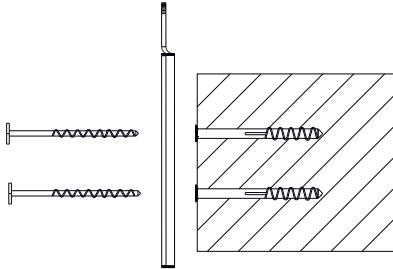

Correct Mount

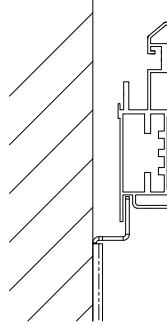

Incorrect Mount

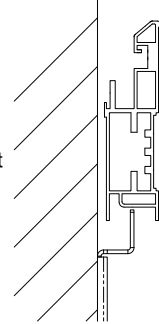

6. Push the top edge of the screen into the wall hanging. During this process, tilt the screen slightly outward (approximately 3°) and release gently.

* If the screen height is found to be inappropriate, re-adjust the hole position of the wall hanging.

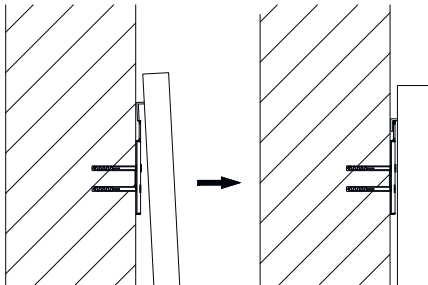

7. Check if the projection screen is full and make sure the display is normal.

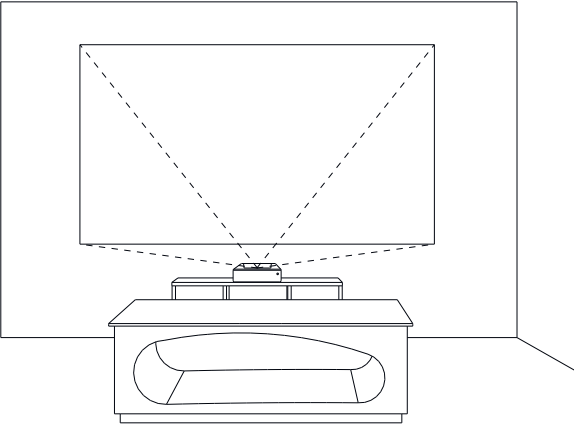

8. Remove the double faced adhesive release paper of Side B of 3 Velcro tapes under the screen, put the screen back on the wall. Press and fix the Velcro tape to complete the installation.

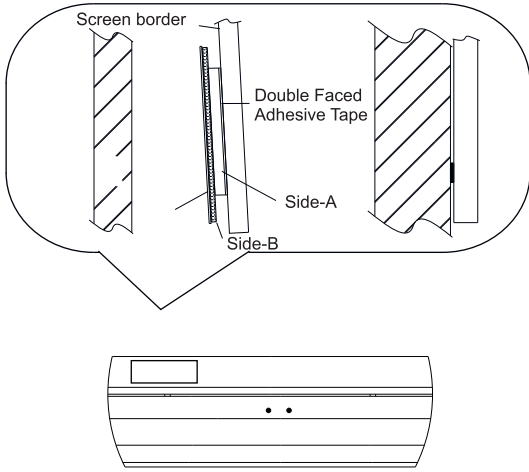

Frequently Asked Questions

1.What is the screen made of?

This product is made of aluminum alloy frame, polymer resin (including multi layer optical structure and nano-particles) and nylon.

2.Weight of the screen.

The net weight of the screen is 14 kg, and the gross weight of the screen (including the package) is 25 kg.

3.Service environment.

For indoor use, temperature is $-10^{\circ}\text{C}\sim 45^{\circ}\text{C}$ and the humidity is $50\pm 20\%$ RH.

As optical screen, this product contains multi-layer optical structure and nano particles that can absorb ambient light and greatly improve the contrast and color saturation of picture display under bright room environment. It is advisable to watch movies and TV in the room with lights on and natural light, but not outdoors in the sun.

4.Storage conditions.

Storage temperature: $-20^{\circ}\text{C}\sim 60^{\circ}\text{C}$

Storage humidity: $30\%\sim 70\%$ RH

5.Maintenance of the screen.

Don' t touch the screen surface with your hands to avoid leaving fingerprints or mimeograph. If there is dust or stains, please wipe the surface of the screen with a clean, soft and lint-free cloth containing small amount of alcohol.



Scan the QR code for other
languages and to watch
the installation video

XGIMI Technology Co., Ltd.
Building A4, No. 1129 Century City Road, New and High-tech
zones, Chengdu City China

service@xgimi.com www.xgimi.com