

DS-2CE12HFT-F28 5 MP Full Time Color Camera

ColorVu



- 5 MP, 2560 × 1944 resolution
- 24-hour color image
- 130 dB true WDR, 3D DNR
- 2.8 mm fixed focal lens
- Smart Light, up to 40 m white light distance
- 4 in 1 video output (switchable TVI/AHD/CVI/CVBS)
- IP67



Specification

Camera	
Image Sensor	5 MP CMOS
Signal System	PAL/NTSC
Resolution	2560 (H) × 1944 (V)
Frame Rate	TVI: 5MP@20fps, 4MP@30fps, 4MP@25fps, 1080p@30fps, 1080p@25fps CVI: 4MP@30fps, 4MP@25fps AHD: 5MP@20fps, 4MP@30fps, 4MP@25fps CVBS: PAL/NTSC
Min. illumination	0.0005 Lux @ (F1.0, AGC ON), 0 Lux with White Light
Shutter Time	PAL: 1/25 s to 1/50, 000 s NTSC: 1/30 s to 1/50, 000 s
Slow Shutter	Max. 16 times
Lens	2.8 mm fixed lens
Horizontal Field of View	2.8 mm, horizontal FOV: 99.7°, vertical FOV: 72°, diagonal FOV: 139.8°
Lens Mount	M16
Strobe Light Alarm	Yes
Day & Night	Color
WDR (Wide Dynamic Range)	≥130 dB
Angle Adjustment	Pan: 0 to 360°, Tilt: 0 to 180°, Rotation: 0 to 360°
Menu	
White Light	Auto/Off
Image Mode	STD/HIGH-SAT
AGC	Yes
Day/Night Mode	Color
White Balance	Auto/Manual
AE (Auto Exposure) Mode	WDR/BLC/HLC/Global/HLS/Anti-banding
Privacy Mask	4 programmable privacy masks
Motion Detection	4 programmable motion areas
Noise Reduction	3D DNR
Language	English
Function	Brightness, Sharpness, Mirror, Smart Light
Interface	
Video Output	Switchable TVI/AHD/CVI/CVBS
General	
Operating Conditions	-40 °C to 60 °C (-40 °F to 140 °F), humidity 90% or less (non-condensing)
Power Supply	12 VDC ± 25% <i>*You are recommended to use one power adapter to supply the power for one camera.</i>
Power Consumption	Max. 4.9 W
Protection Level	IP67
https://www.conecticplus.com/	

White Light Range	Up to 40 m
Communication	HIKVISION-C
Dimensions	82.6 mm × 77.1 mm × 220.4 mm (3.25" × 3.04" × 8.68")
Weight	Approx. 565 g (1.25 lb.)

Available Model

DS-2CE12HFT-F28

Dimension

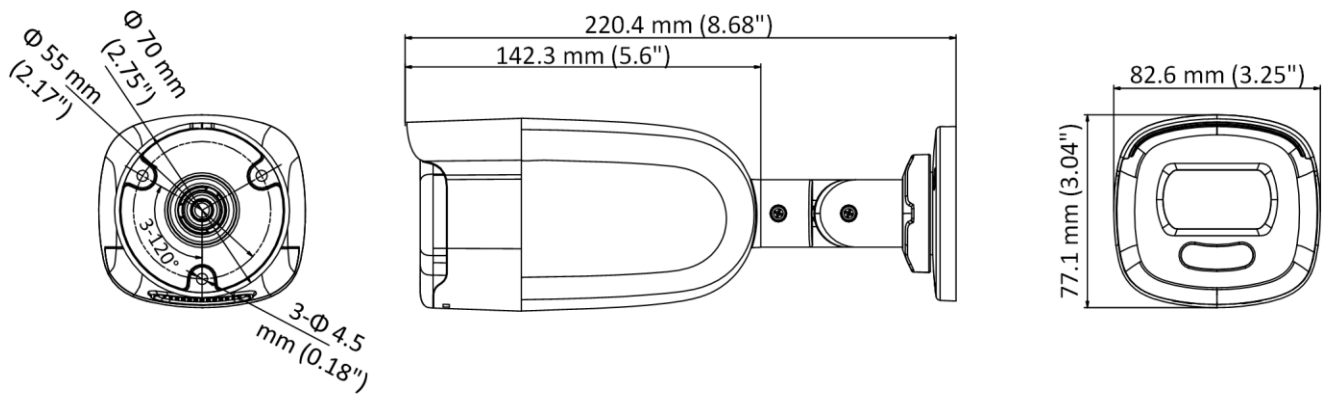

Accessory



DS-1280ZJ-XS
Junction Box

Distributed by

**HIKVISION®****Headquarters**

No.555 Qianmo Road, Binjiang District,
Hangzhou 310051, China
T +86-571-8807-5998
overseasbusiness@hikvision.com

Hikvision USA
T +1-909-895-0400
sales.usa@hikvision.com

Hikvision Australia
T +61-2-8599-4233
salesau@hikvision.com

Hikvision India
T +91-22-28469900
sales@pramahikvision.com

Hikvision Canada
T +1-866-200-6690
sales.canada@hikvision.com

Hikvision Thailand
T +66-2-775-9749
sales.thailand@hikvision.com

Hikvision Europe
T +31-23-5542770
sales.eu@hikvision.com

Hikvision Italy
T +39-0438-6902
info.it@hikvision.com

Hikvision Brazil
T +55 11 3318-0050
Latam.support@hikvision.com

Hikvision Turkey
T +90 (216)521 7070- 7074
sales.tr@hikvision.com

Hikvision Malaysia
T +601-7652-2913
sales.my@hikvision.com

Hikvision UK & Ireland
T +01628-902140
sales.uk@hikvision.com

Hikvision South Africa
Tel: +27 (10) 0351172
sale.africa@hikvision.com

Hikvision France
T +33(0)1-85-330-450
info.fr@hikvision.com

Hikvision Kazakhstan
T +7-727-9730667
nikia.panfilov@hikvision.ru

Hikvision Vietnam
T +84-974270888
sales.vt@hikvision.com

Hikvision UAE
T +971-4-4432090
salesme@hikvision.com

Hikvision Singapore
T +65-6684-4718
sg@hikvision.com

Hikvision Spain
T +34-91-737-16-55
info.es@hikvision.com

Hikvision Tashkent
T +99-87-1238-9438
uzb@hikvision.ru

Hikvision Hong Kong
T +852-2151-1761
info.hk@hikvision.com

Hikvision Russia
T +7-495-669-67-99
sateru@hikvision.com

Hikvision Korea
T +82-(0)31-731-8817
sales.korea@hikvision.com

Hikvision Poland
T +48-22-460-01-50
info.pl@hikvision.com

Hikvision Indonesia
T +62-21-2933759
Sales.Indonesia@hikvision.com

Hikvision Colombia
sales.colombia@hikvision.com