

# REPARABILITY INDEX WORKSHEET OF ROBOTIC VACUUM

## GENERAL INSTRUCTIONS

### PURPOSE OF THE FILE

This Excel file calculates the reparability index of a robotic vacuum

### REGULATORY FRAMEWORK

**Article L. 541-9-2 of the French Environmental Code states that :** Manufacturers, importers, marketers and other retailers which put electrical and electronic equipment (EEE) on the French market have to inform, free of charge, downstream sellers and any person who made the request of "**the reparability index" of their products, as well as the paramaters explaining how such index was established.** This reparability index will inform consumers about the ability to repair the product category concerned. **All information entered in this file must be truthful and verifiable.**

The methods and rules of implementation for the reparability index are specified in the reparability index Decree N°2020-1757 2020-12-29 for electrical and electronic equipment (EEE), the Decision 2020-12-29 on display conditions and parameters for calculating the reparability index and the Decision 2022-05-04 on criteria, subcriteria, rating system and display of the reparability index of robotic vacuum.

**A complementary instructions manual provides explanatory informations and additional instructions on how to apply Decree and Orders of the reparability index of electrical and electronic equipement.**

### FILE CONTENT

<b>General instructions</b>	Description of the purpose of this Excel file, description of regulatory framework of the reparability index and description of file content and how it will be completed.
<b>Product information</b>	Description of the product and the assessment of its reparability index.
<b>C1_Documentation</b>	Detailed criteria used to calculate the reparability index of the product.
<b>C2_Disassembly</b>	On each tab page, all 'orange boxes' must be completed by selecting the right information from the 'drop-down list' or by directly entering the right information in the box (e.g. criterion 4 : price and file to be send).
<b>C3_Availability of spare parts</b>	When the information is entered, the concerned box changes to 'green'. No box should be left unanswered. Note that the cells must be completed one by one (they must not be stretched).
<b>C4_Price</b>	
<b>C5_Specific</b>	
<b>Final score</b>	This tab automatically calculate final score of the reparability index of the product and also scores per criteria and sub-criteria, before and after weighting.
<b>Note finale</b>	This tab is the French translation of the "Final score" tab. It is automatically completed. This tab is to be sent to all applicants.
<b>Annex 1</b>	Details about the therminology used for the reparability index.
<b>Annex 2</b>	Details about the list of "basic" tools and their reference standards.
<b>Annex 3</b>	Details and application case about the concept of disassembly step.

REINTIALISER LES CHOIX

This button resets all data entered into the file. If you want to execute this action, please enable macros and click on the button. **WARNING: this action cannot be undone.**

**INFORMATIONS RELATING TO THE PRODUCT AND  
THE CALCULATION OF ITS REPAIRABILITY INDEX**

*robotic vacuum*

DATE OF CALCULATION	14/10/2022
REQUESTOR OF THE ASSESSMENT	
LAST NAME	Please fill out
FIRST NAME	Please fill out
MAIL	Please fill out
PHONE NUMBER	Please fill out
RESPONSIBLE FOR EVALUATION	
LAST NAME	LI
FIRST NAME	YOUXIN
MAIL	<a href="mailto:liy@dreame.tech">liy@dreame.tech</a>
PHONE NUMBER	(+86) 13750086170
RATED PRODUCT	
Producer's or importer's name or trademark	DREAME
Producer or importer adress	Floor, Leighton Centre, 77 Leighton Road, Causeway Bay, Hong
Producer's or importer's model identifier	W10

**CRITERION 1 : DOCUMENTATION**

*Robotic vacuum*

**SUB-CRITERION 1.1 : COMMITMENT ON THE AVAILABILITY OVER TIME (WITHOUT CHARGE) OF THE TECHNICAL DOCUMENTATION AND THE OTHER DOCUMENTATION RELATED TO USER AND MAINTENANCE INSTRUCTIONS**

**ADDITIONAL INFORMATIONS:**

**Documents/informations:** The information can be freely distributed at the initiative of the producer in various physical or dematerialized documents. Scoring points are awarded if the information referred to is available in any document.

**Language of documents:** In accordance with the law of August 4, 1994 on the use of the French language, information intended for consumers must be drawn up in French ; English is tolerated for very technical aspects intended for professional repairers (example: technical bulletins).

**Technical bulletins:** This wording covers announcements made by the producer to professional repairers, informing them, for example, of recently discovered bugs, of the corrections to be made, of the supply disruption of parts which have been replaced by others. Points are awarded if the edition of a technical bulletin is planned on an ongoing basis (when necessary).

**Information on access to professional repairers:** The producer or importer is free to indicate to consumers the professional repairers of his choice, but it is advisable to mention at least the repairer directories listed by Ademe : [www.annuaire-reparation.fr](http://www.annuaire-reparation.fr)

**Instructions for self-repair:** Points corresponding to years of availability are only granted if one or more operations are specified to consumers for self-repair, with adequate safety instructions, in a specific section under the title "self-repair", for example in the technical manual or of the instructions for use and maintenance. Article L 441-5 of the Consumer Code specifies the responsibility of the producer regarding self-repair.

Commitment on the availability over time of the documentation (in years)	Column B Repairers		Column C Consumers			
	Duration of availability	Subtotal	Duration of availability	Subtotal		
1.1.A The unequivocal identification of the product (type of product, trademark, trade name, model, and possibly, serial number)	if X ≥ 13 years	13	if X ≥ 13 years	13		
1.1.B A disassembly map or exploded view	if X ≥ 13 years	13	Not applicable	13		
1.1.C Wiring and connection diagrams	if X ≥ 13 years	13	Not applicable	13		
1.1.D Electronic boards diagrams	if X ≥ 13 years	13	Not applicable	13		
1.1.E List of necessary repair and test equipment	if X ≥ 13 years	13	Not applicable	13		
1.1.F Technical manual of instructions for repair	if X ≥ 13 years	13	Not applicable	13		
1.1.G Diagnostic fault and error codes	if X ≥ 13 years	13	Not applicable	13		
1.1.H Component and diagnosis information	if X ≥ 13 years	13	Not applicable	13		
1.1.I Instructions for software and firmware (including reset software)	if X ≥ 13 years	13	Not applicable	13		
1.1.J Information on how to access data records of reported failure incidents stored on the product	if X ≥ 13 years	13	Not applicable	13		
1.1.K Technical bulletins	if X ≥ 13 years	13	Not applicable	13		
1.1.L Specific guidance for self-repair (recommended operations, safety and repair instructions, any implications for the guarantee)*			Not applicable	13		
1.1.M How to get access to professional repairers			if X ≥ 13 years	13		
1.1.N Failures detection and required action (consumers approach)			Not applicable	13		
1.1.O User and maintenance instructions			if X ≥ 13 years	13		
<b>Total sub-criterion 1.1</b>		<b>143</b>		<b>195</b>	<b>338</b>	<b>/338</b>
					<b>10,0</b>	<b>/10</b>

\*Points corresponding to years of availability are only awarded if one or more operations are specified to consumers for self-repair, with adequate safety instructions, in a

**CRITERION 2 : DISASSEMBLY, ACCESSIBILITY, TOOLS, FASTENERS**

*robotic vacuum*

**SUB-CRITERION 2.1 : EASE OF DISASSEMBLY OF SPARE PARTS - BROKEN / MALFUNCTIONING PARTS (LIST 2)**

**ADDITIONAL INFORMATIONS:**

Details of the dismantling steps can be found on the right side of this sheet and in Annex 3 grid.  
 A part is considered non-removable if it is not individually accessible and cannot be detached from the equipment or a sub-assembly, with a view to its replacement. In this case, the points for the corresponding criterion 2.1 are not awarded.  
 A link is established between the rating of sub-criterion 2.1 and that of sub-criterion 3.1, in the case where a part cannot be dismantled: the zero score is then passed on from one sub-criterion to another.

**PARTICULAR CASE OF ROBOTIC VACUUM**

The dust collector or bag access trap is not taken into account in criterion 2.1 Ease of disassembly

Ease of disassembly		Rating	
List 2 : Broken / malfunctioning parts		Number of steps required to disassemble the spare part	Subtotal
2.1.A	Battery	if $DDi < 4$	3
2.1.B	Side brush motor	if $12 > DDi \geq 6$	2
2.1.C	Brush bar	if $DDi \geq 6$	0
2.1.D	Dust collector or bag access trap		
2.1.E	Follower wheels	if $DDi \geq 6$	0
<b>Total sub-criterion 2.1</b>			5 /12 4,2 /10

**SUB-CRITERION 2.2 : NECESSARY TOOLS TO REMOVE SPARE PARTS - BROKEN / MALFUNCTIONING PARTS (LIST 2)**

**ADDITIONAL INFORMATIONS:**

- Necessary tools to unitarily disassemble a spare part include all tools used to get access and disassemble the concerned part without causing damage to the product (which might include getting access to fasteners).  
 - Tools used are classified according to the complexity of the operation to final users and the availability of tools.  
 - In case of using different types of tools in the disassembly and reassembly sequences of a spare part, the worst score shall be considered.

Necessary tools for disassembly		Rating	
List 2 : Broken / malfunctioning parts		Type of tools used for disassembly	Subtotal
2.2.A	Battery	D : Removable with no tool with tools supplied with the product or with basic	4
2.2.B	Side brush motor	D : Removable with no tool with tools supplied with the product or with basic	4
2.2.C	Brush bar	D : Removable with no tool with tools supplied with the product or with basic	4
2.2.D	Dust collector or bag access trap	D : Removable with no tool with tools supplied with the product or with basic	4
2.2.E	Follower wheels	D : Removable with no tool with tools supplied with the product or with basic	4
<b>Total sub-criterion 2.2</b>			20 /20 10,0 /10

**SUB-CRITERION 2.3 : CHARACTERISTICS OF FASTENERS FOR THE ASSEMBLY OF SPARE PARTS (LISTS 1 AND 2)**

**ADDITIONAL INFORMATIONS:**

- Fasteners : A hardware device that mechanically or magnetically connects or fixes two or more objects, parts or pieces. A fastener is generally non-permanent, i.e., it can be easily removed or disassembled without damaging the objects, parts or pieces connected or fixed together (e.g., screws or clips). Welds and some glues are in contrast to permanent fixings. Adhesives are considered non-reusable fasteners unless new ones are supplied with the spare part.  
 - Fasteners removed are classified according to their accessibility, reusability, amovibility and also their constraints imposed to the product reparability (e.g. fasteners causing damage or leaving welding or glue residues which preclude reusability of the removed part).  
 - In case of removing different types of fasteners during the disassembly step of a spare part, the worst score shall be considered.

Fasteners characteristics		Rating	
List 1 : Functional parts List 2 : Broken / malfunctioning parts		Type of fasteners	Subtotal
2.3.A	Guidance motor (with or without wheel drive)	C : Removable and reusable	2
2.3.B	Filter / pre-filter	C : Removable and reusable	2
2.3.C	Electronic control board	C : Removable and reusable	2
2.3.D	Power electronic card	C : Removable and reusable	2
2.3.E	Bumper captor	C : Removable and reusable	2
2.3.F	Charging station	C : Removable and reusable	2
2.3.G	Storage station	C : Removable and reusable	2
2.3.H	On/Off switch	C : Removable and reusable	2
2.3.I	Drive wheels (with or without guidance motor)	C : Removable and reusable	2
2.3.J	Main motor	C : Removable and reusable	2
2.3.K	Battery	C : Removable and reusable	2
2.3.L	Side brush motor	C : Removable and reusable	2
2.3.M	Brush bar	C : Removable and reusable	2
2.3.N	Dust collector or bag access trap	C : Removable and reusable	2
2.3.O	Follower wheels	C : Removable and reusable	2
<b>Total sub-criterion 2.3</b>			30 /30 10,0 /10

<b>CRITERION 3 : AVAILABILITY OF SPARE PARTS</b>	<i>Robotic vacuum</i>
--	-----------------------

**SUB-CRITERION 3.1 : COMMITMENT ON THE AVAILABILITY OVER TIME OF SPARE PARTS - BROKEN/MALFUNCTIONING PARTS (LIST 2)**

**ADDITIONAL INFORMATIONS:**  
**Definition of spare parts distributor:** The definition of a spare parts distributor is given in the glossary in appendix 1 of the gird  
**Commitments on the availability of spare parts and delivery times** (except Sunday and fest days): To award points to the A columns, the producer should have his own in-house repair service (example: via the after-sales service). Whether for the period of availability of spare parts or the delivery time, the producer or the importer must retain, among all of their practices towards authorized and independent repairers, the period or the most penalizing time for each spare part. In the event that the producer or importer does not make spare parts directly available to independent repairers, then points are not awarded in column C of criterion 3.1, 3.2, 3.3 and 3.4.  
In addition, in the event that the producer or importer does not have an approved repairers network, the points are awarded based on the most penalizing practices towards independent repairers.  
**Delivery time:** The delivery time is understood in working days between the day of the order and the day of arrival at the actor concerned.

Commitment on the availability over time of spare parts (in years)		Column A Producer		Column B Spare parts retailers		Column C Repairers		Column D Consumers	
		Duration of availability	Subtotal	Duration of availability	Subtotal	Duration of availability	Subtotal	Duration of availability	Subtotal
<b>List 2 : Broken / malfunctioning parts</b>									
3.1.A	Battery	if X < 9 years	0	if X < 9 years	0	if X < 9 years	0	if X < 9 years	0
3.1.B	Side brush motor	if X < 9 years	0	if X < 9 years	0	if X < 9 years	0	if X < 9 years	0
3.1.C	Brush bar	if X < 9 years	0	if X < 9 years	0	if X < 9 years	0	if X < 9 years	0
3.1.D	Dust collector or bag access trap	if X < 9 years	0	if X < 9 years	0	if X < 9 years	0	if X < 9 years	0
3.1.E	Follower wheels	if X < 9 years	0	if X < 9 years	0	if X < 9 years	0	if X < 9 years	0
<b>Total sub-criterion 3.1</b>			0		0		0		0
								0	/260
								0	/10

**SUB-CRITERION 3.2 : COMMITMENT ON THE AVAILABILITY OVER TIME OF SPARE PARTS - FUNCTIONAL PARTS (LIST 1)**

Commitment on the availability over time of spare parts (in years)		Column A Producer		Column B Spare parts retailers		Column C Repairers		Column D Consumers	
		Duration of availability	Subtotal	Duration of availability	Subtotal	Duration of availability	Subtotal	Duration of availability	Subtotal
<b>List 1 : Functional parts</b>									
3.2.A	Guidance motor (with or without wheel drive)	if X < 9 years	0	if X < 9 years	0	if X < 9 years	0	if X < 9 years	0
3.2.B	Filter / pre-filter	if X < 9 years	0	if X < 9 years	0	if X < 9 years	0	if X < 9 years	0
3.2.C	Electronic control board	if X < 9 years	0	if X < 9 years	0	if X < 9 years	0	if X < 9 years	0
3.2.D	Power electronic card	if X < 9 years	0	if X < 9 years	0	if X < 9 years	0	if X < 9 years	0
3.2.E	Bumper captor	if X < 9 years	0	if X < 9 years	0	if X < 9 years	0	if X < 9 years	0
3.2.F	Charging station	if X < 9 years	0	if X < 9 years	0	if X < 9 years	0	if X < 9 years	0
3.2.G	Storage station	if X < 9 years	0	if X < 9 years	0	if X < 9 years	0	if X < 9 years	0
3.2.H	On/Off switch	if X < 9 years	0	if X < 9 years	0	if X < 9 years	0	if X < 9 years	0
3.2.I	Drive wheels (with or without guidance motor)	if X < 9 years	0	if X < 9 years	0	if X < 9 years	0	if X < 9 years	0
3.2.J	Main motor	if X < 9 years	0	if X < 9 years	0	if X < 9 years	0	if X < 9 years	0
<b>Total sub-criterion 3.2</b>			0		0		0		0
								0	/520
								0	/10

**SUB-CRITERION 3.3 : COMMITMENT ON THE DELIVERY TIME OF SPARE PARTS - BROKEN/MALFUNCTIONING PARTS (LIST 2)**

Commitment on the delivery time of spare parts (in working days)		Column A Producer		Column B Spare parts retailers		Column C Repairers		Column D Consumers	
		Delivery time	Subtotal	Delivery time	Subtotal	Delivery time	Subtotal	Delivery time	Subtotal
<b>List 2 : Broken / malfunctioning parts</b>									
3.3.A	Battery	if X > 10 days	0	if X > 10 days	0	if X ≤ 3 days	3	if X ≤ 3 days	3
3.3.B	Side brush motor	if X > 10 days	0	if X > 10 days	0	if X ≤ 3 days	3	if X ≤ 3 days	3
3.3.C	Brush bar	if X > 10 days	0	if X > 10 days	0	if X ≤ 3 days	3	if X ≤ 3 days	3
3.3.D	Dust collector or bag access trap	if X > 10 days	0	if X > 10 days	0	if X ≤ 3 days	3	if X ≤ 3 days	3
3.3.E	Follower wheels	if X > 10 days	0	if X > 10 days	0	if X ≤ 3 days	3	if X ≤ 3 days	3
<b>Total sub-criterion 3.3</b>			0		0		15		15
								30	/60
								5,0	/10

**SUB-CRITERION 3.4 : COMMITMENT ON THE DELIVERY TIME OF SPARE PARTS - FUNCTIONAL PARTS (LIST 1)**

Commitment on the delivery time of spare parts (in working days)		Column A Producer		Column B Spare parts retailers		Column C Repairers		Column D Consumers	
		Delivery time	Subtotal	Delivery time	Subtotal	Delivery time	Subtotal	Delivery time	Subtotal
<b>List 1 : Functional parts</b>									
3.4.A	Guidance motor (with or without wheel drive)	if X > 10 days	0	if X > 10 days	0	if X ≤ 3 days	3	if X ≤ 3 days	3
3.4.B	Filter / pre-filter	if X > 10 days	0	if X > 10 days	0	if X ≤ 3 days	3	if X ≤ 3 days	3
3.4.C	Electronic control board	if X > 10 days	0	if X > 10 days	0	if X ≤ 3 days	3	if X ≤ 3 days	3
3.4.D	Power electronic card	if X > 10 days	0	if X > 10 days	0	if X ≤ 3 days	3	if X ≤ 3 days	3
3.4.E	Bumper captor	if X > 10 days	0	if X > 10 days	0	if X ≤ 3 days	3	if X ≤ 3 days	3
3.4.F	Charging station	if X > 10 days	0	if X > 10 days	0	if X ≤ 3 days	3	if X ≤ 3 days	3
3.4.G	Storage station	if X > 10 days	0	if X > 10 days	0	if X ≤ 3 days	3	if X ≤ 3 days	3
3.4.H	On/Off switch	if X > 10 days	0	if X > 10 days	0	if X ≤ 3 days	3	if X ≤ 3 days	3
3.4.I	Drive wheels (with or without guidance motor)	if X > 10 days	0	if X > 10 days	0	if X ≤ 3 days	3	if X ≤ 3 days	3
3.4.J	Main motor	if X > 10 days	0	if X > 10 days	0	if X ≤ 3 days	3	if X ≤ 3 days	3
<b>Total sub-criterion 3.4</b>			0		0		30		30
								60	/120
								5,0	/10

**CRITERION 4 : PRICE OF SPARE PARTS**

*Robotic vacuum*

**ADDITIONAL INFORMATIONS:**

**Deduction of delivery costs:** The principle adopted is to make a calculation excluding transport or delivery costs. If the latter are included in the tariffs of the general terms and conditions of sale, it is up to the producer or importer to deduct them in order to calculate the ratio. In particular for the price of spare parts, two methods are possible for deducting transport or delivery costs: individually for each of the parts in list 2 or on a flat-rate basis (in absolute value or as a percentage). The same applies to the price of new equipment.

**Spare part(s) forming part of a batch:** If one or more of the parts in list 2 are part of a batch offered for sale or of any other subset of inseparable parts, the price of the part concerned is the price of this batch or subset.

**Part not available:** In the event that, at the time the index is calculated, a part from list 2 is not available, the number of points awarded for criterion 4 relating to the price of spare parts is 0.

**Parts not managed by the producer or importer:** If parts from list 2 are not managed by the producer or importer, the price of the parts to be considered is then that of the supplier's general terms and conditions of sale at the time of the index calculation.

**Options for products with the same reference:** If options are offered for the same reference, and do not influence the technical characteristics for the purpose of calculating the index, then the calculation of the price ratio to be achieved is based on the price of spare parts and the price of the most current version of the product concerned.

**Absence of a part:** If the equipment does not include a part listed in list 1 or 2 of the category concerned, then the price of the absent part does not appear in the calculation of the ratio.

PRICE Criterion	RATING			
	Value (euros)	Score (%)	POINTS (/100)	FINAL SCORE (/10)
Pre-tax price of the most expensive spare part (list 2)	176	9,68%	100	10,0
Average pre-tax price of other spare parts (list 2)	7,8			
Manufacturer's pre-tax price of concerned model	949			

The number of points obtained for this criterion is determined as follows:

- if the result is greater than 0.3 then the number of points is 0;

- if the result is less than 0.1 then the number of points is 100;

- if the result is between 0.1 and 0.3 then the number of points is determined according to the following correspondence table :

Ratio	0,1	0,11	0,12	0,13	0,14	0,15	0,16	0,17	0,18	0,19	0,2	0,21	0,22	0,23	0,24	0,25	0,26	0,27	0,28	0,29	0,3
Points	100	95	90	85	80	75	70	65	60	55	50	45	40	35	30	25	20	15	10	5	0



<b>REPAIRABILITY INDEX CALCULATION AND PRESENTATION OF THE PARAMETERS WHICH ALLOWED TO ESTABLISH IT</b>	<i>Robotic vacuum</i>
---	-----------------------

Date of calculation	14/10/2022
Producer's or importer's name or trademark	DREAME
Producer or importer address	17th Floor, Leighton Centre, 77 Leighton Road, Causeway Bay, Hong kong
Producer's or importer's model identifier	W10

**This "FINAL\_SCORE" tab in English is purely indicative. In order to meet regulatory obligations, only the "NOTE\_FINAL" tab in French (see the next tab) is to be sent. Note: The results are automatically reported in the French tab.**

Criteria	Sub-criteria	Score of subcriterion /10	Weighting factor of subcriterion	Score of criterion /20	Total criteria scores /100	
CRITERION 1 : DOCUMENTATION	1.1 Availability of the technical documentation and other documentation related to user and maintenance instructions	10,0	2	20,0	76,7	
CRITERION 2 : DISASSEMBLY, ACCESSIBILITY, TOOLS, FASTENERS	2.1 Ease of disassembly parts from List 2*	4,2	1	14,2		
	2.2 Necessary tools (List 2)	10,0	0,5			
	2.3 Fasteners characteristics parts from List 1** and List 2	10,0	0,5			
CRITERION 3 : AVAILABILITY OF SPARE PARTS	3.1 Availability over time parts from List 2	0	1	2,5		
	3.2 Availability over time parts from List 1	0	0,5			
	3.3 Delivery time parts from List 2	5,0	0,3			
	3.4 Delivery time parts from List 1	5,0	0,2			
CRITERION 4 : PRICE OF SPARE PARTS	4. Ratio between price of parts from list 2 to the price of the product	10,0	2	20,0		20,0
CRITERION 5 : SPECIFIC CRITERION	5.1 Accesibility of usage-counter to consumers	10,0	1			
	5.2 Free remote assistance	10,0	0,5			
	5.3 Possibility to reset softwares	10,0	0,5			
<b>Reparability index on 10</b>					<b>7,7</b>	

\* list 2: list of a maximum of 3 to 5 spare parts (depending on the category of equipment concerned) whose broken or malfunctioning parts are the most frequent;

\*\* list 1: list of a maximum of 10 other spare parts (depending on the category of equipment concerned) whose good condition is necessary for the operation of the equipment.



**CALCUL DE L'INDICE DE RÉPARABILITÉ ET  
PRÉSENTATION DES PARAMÈTRES AYANT PERMIS DE L'ÉTABLIR**

*Aspirateur robot*

FICHE D'INFORMATION À TRANSMETTRE AUX DEMANDEURS  
(cf. Article L. 541-9-2 du Code de l'environnement)

Date du calcul	14/10/2022
Nom ou marque commerciale du producteur ou de l'importateur	DREAME
Adresse du producteur ou de l'importateur	17th Floor, Leighton Centre, 77 Leighton Road, Causeway Bay, Hong kong
Référence du modèle donnée par le producteur ou l'importateur	W10

Critère	Sous-critère	Note du sous-critère sur 10	Coefficient du sous-critère	Note du critère sur 20	Total des notes des critères sur 100
<b>CRITÈRE 1 : DOCUMENTATION</b>	1.1 Durée de disponibilité de la documentation technique et relative aux conseils d'utilisation et d'entretien	10,0	2	20,0	76,7
<b>CRITÈRE 2 : DÉMONTABILITÉ, ACCÈS, OUTILS, FIXATIONS</b>	2.1 Facilité de démontage des pièces de la liste 2*	4,2	1	14,2	
	2.2 Outils nécessaires (liste 2)	10,0	0,5		
	2.3 Caractéristiques des fixations entre les pièces de la liste 1** et de la liste 2	10,0	0,5		
<b>CRITÈRE 3 : DISPONIBILITÉ DES PIÈCES DÉTACHÉES</b>	3.1 Durée de disponibilité des pièces de la liste 2	0	1	2,5	
	3.2 Durée de disponibilité des pièces de la liste 1	0	0,5		
	3.3 Délais de livraison des pièces de la liste 2	5,0	0,3		
	3.4 Délais de livraison des pièces de la liste 1	5,0	0,2		
<b>CRITÈRE 4 : PRIX DES PIÈCES DÉTACHÉES</b>	4. Rapport prix des pièces de la liste 2 sur prix de l'équipement neuf	10,0	2	20,0	
<b>CRITÈRE 5 : CRITÈRE SPÉCIFIQUE</b>	5.1 Accessibilité du compteur d'usage	10,0	1	20,0	
	5.2 Assistance à distance sans frais	10,0	0,5		
	5.3 Possibilité de réinitialisation logicielle	10,0	0,5		
<b>Note de l'indice sur 10</b>					<b>7,7</b>

\*liste 2 : liste des 3 à 5 pièces détachées au maximum (selon la catégorie d'équipements concernée) dont la casse ou les pannes sont les plus fréquentes ;

\*\*liste 1 : liste de 10 autres pièces détachées au maximum (selon la catégorie d'équipements concernée) dont le bon état est nécessaire au fonctionnement de l'équipement.

**ANNEX 1 : TERMINOLOGY USED FOR THE REPARABILITY INDEX**



The definitions of the following terms are specified in the decree relating to the reparability index for electrical and electronic equipment:  
 "Making available on the market", "Placing on the market", "producer", "importer", "distributor", "seller", "distance selling", "model".

<b>Authorized repairer</b>	The authorized repairer is often referred to as a technical station or authorized service center. It is a professional repairer for whom one or more contracts precisely define the relationship between the authorized repairer and the producer(s).	Based on the technical expertise of the reparability index working groups
<b>Independent repairer</b>	Independent repairers are repairers in the sense of "professional craftsmen repairers" designating repair companies listed in the trade directory with an APE or NAFA code. They are professional repairers who do not fall into the category of authorized repairers. For example, 95.11 Z-Z: Repair of computers and peripheral equipment; 95.21 Z-Z: Repair of televisions, radio receivers, VCRs, CD and DVD players, camcorders for domestic use; 95.22 Z-Z: Repair of household appliances and home and garden equipment.	
<b>Professional repairer</b>	Authorized repairer or independent repairer.	
<b>Distributor of spare parts</b>	Any moral or physical person in the supply chain, other than the producer or importer, who offers a spare part for sale. They are commonly referred to as "spare parts wholesalers".	According to Standard NF EN 45554 "General methods for the evaluation of the repair, reuse and improvement capacity of energy-related products", 2020.
<b>Disassembly</b>	The process by which a product, spare part or fastener is disassembled so that it can then be reassembled and made operational.	
<b>Reassembly</b>	The process by which a product, a spare part or a fastener is reassembled so as to fulfill its functional role and be made operational.	
<b>Reuse / Reusable</b>	The process by which a product, spare part or fastener, having reached the end of its first use, is used for the same purpose for which it was designed. Reuse after a second or subsequent use(s) is also considered to be reuse.	
<b>Factory Restoration</b>	A specific functionality or setting to be activated by the customer, if the product allows it, to restore the default value of a specific functionality of the device as set at the factory and available when the customer first uses the product.	Inspired by the Commission regulation (EU) 2019/2021
<b>Update / Upgrade</b>	The process of improving the functionality, performance, capacity or aesthetics of a product. This process may involve changes to the software, firmware and/or a hardware component of the product.	According to Standard NF EN 45554 "General methods for the evaluation of the repair, reuse and improvement capacity of energy-related products", 2020.
<b>Corrective update</b>	An update performed after a failure has been detected and intended to restore an asset or software to a state in which it can perform a required function. This type of update corrects hardware or software malfunctions or non-conformity but does not add new functionality.	Inspired by the AFNOR NF EN 13306 X 60-319 standard of June 2011 "All the technical, administrative and management actions during the life cycle of an asset, intended to maintain or restore it to a state in which it can perform the required function"
<b>Evolutionary update</b>	Upgrading, which consists of gradually modifying the software application by adding new features or additional modules, or by replacing an existing function with another, or even by proposing a different approach.	
<b>Fastener</b>	A hardware device that mechanically or magnetically connects or fixes two or more objects, parts or pieces. A fastener is generally non-permanent, i.e., it can be easily removed or disassembled without damaging the objects, parts or pieces connected or fixed together (e.g., screws or clips). Welds and some glues are in contrast to permanent fixings. Adhesives are considered non-reusable fasteners unless new ones are supplied with the spare part.	Inspired by, "Fasteners - Their Needs and Types", Bright Hub Engineering, 2020.
<b>Reusable fastener</b>	See the definition of "reusable".	According to Standard NF EN 45554 "General methods for the evaluation of the repair, reuse and improvement capacity of energy-related products", 2020.
<b>Removable fastener</b>	An original fastener system that can be completely removed (without causing damage or leaving residue).	
<b>Proprietary tool</b>	A tool that is not commercially available and is owned exclusively by one party or company, and under which its use by another party (an end user or customer) involves copyright, license and/or cost.	Inspired by Will Kenton, "Proprietary Technology", 2019.
<b>Part / Spare parts</b>	A unitary element in the composition of the equipment.	

## ANNEX 2 : BASIC TOOLS AND THEIR REFERENCE STANDARDS

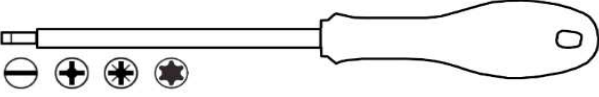
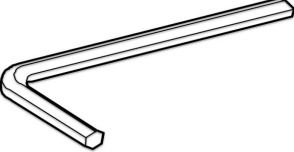
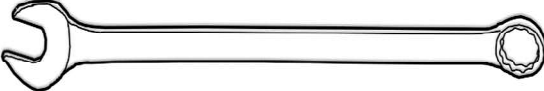
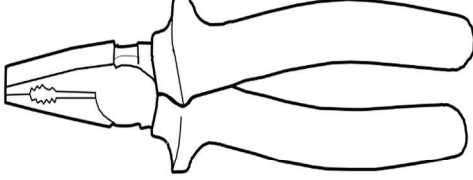
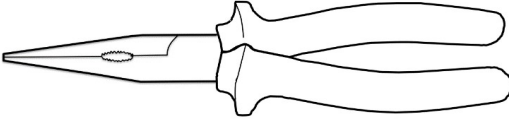
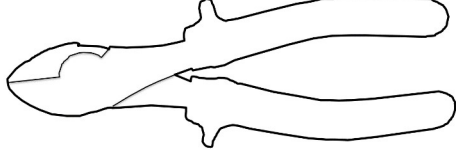
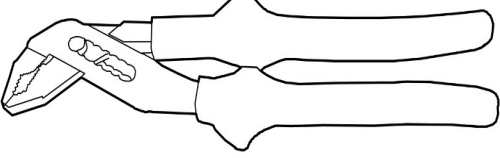
According to the European Standard NF EN 45554 "General methods for the assessment of the ability to repair, reuse and upgrade energy-related products", 2020.

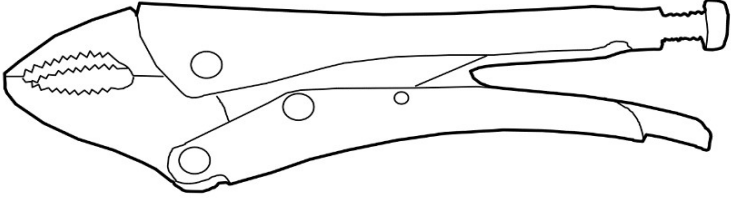
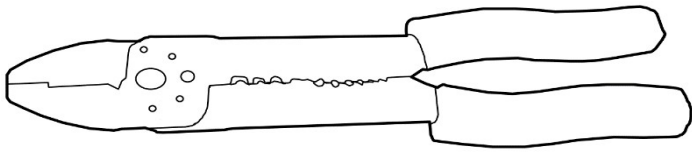
Tool type	Illustration (informative example)	Reference
Screwdriver for slotted heads, cross recess or for hexalobular recess heads		ISO 2380, ISO 8764, ISO 10664
Hexagon socket key		ISO 2936
Combination wrench		ISO 7738
Combination pliers		ISO 5746
Half round nose pliers		ISO 5745
Diagonal cutters		ISO 5749
Multigrip pliers (multiple slip joint pliers)		ISO 8976

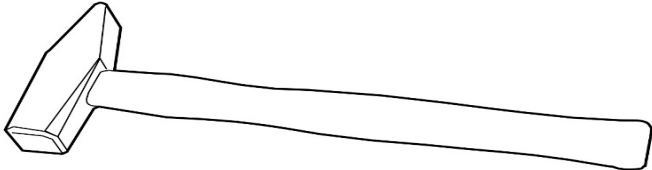
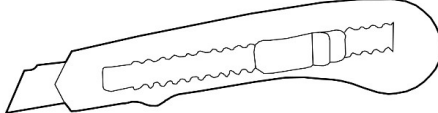
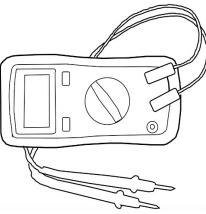
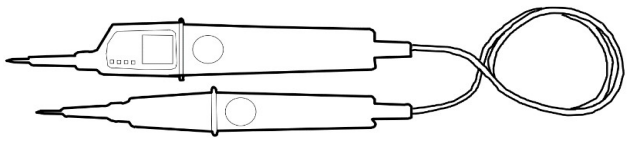
<p>Locking pliers</p>		
<p>Combination pliers for wire stripping and terminal crimping</p>		
<p>Prying lever</p>		
<p>Tweezers</p>		
<p>Hammer, steel head</p>		<p>ISO 15601</p>
<p>Utility knife (cutter) with snap-off blades</p>		
<p>Multimeter</p>		
<p>Voltage tester</p>		

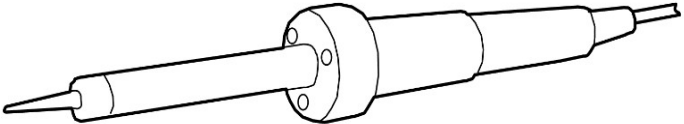
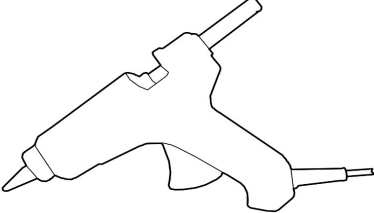
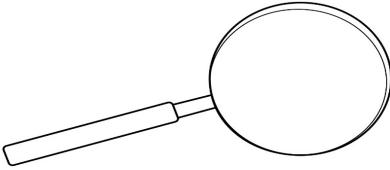
Soldering iron	 A line drawing of a soldering iron. It features a long, thin metal tip on the left, a central cylindrical body with a circular collar in the middle, and a shorter, thicker handle on the right.	
Hot glue gun	 A line drawing of a hot glue gun. It has a pistol-grip handle on the right, a trigger, and a nozzle on the left. A small tube of glue is visible at the bottom right.	
Magnifying glass	 A line drawing of a magnifying glass. It consists of a circular lens and a simple handle attached to the left side.	

**ANNEX 3 : DETAILS ABOUT THE CONCEPT OF DISASSEMBLY STEP ANI**

## D APPLICATION CASE