

▶ DA	Brugsanvisning	2
NL	Gebruiksaanwijzing	42
EN	User Manual	83
FR	Notice d'utilisation	123
DE	Benutzerinformation	166
IT	Istruzioni per l'uso	211
ES	Manual de instrucciones	255
SV	Bruksanvisning	296

USER MANUAL

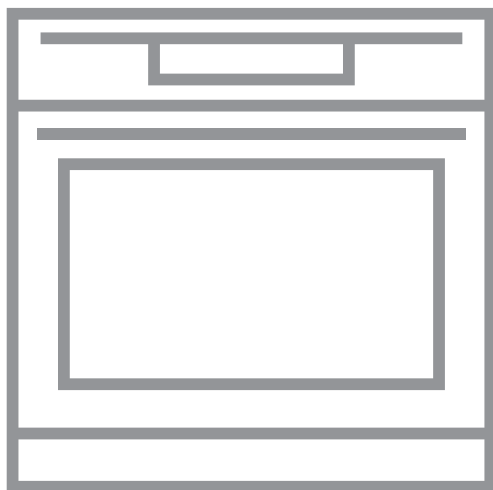

BSE77280M
BSE77228BM
BSK772280M
BSS772280B

AEG

TIL PERFEKTE RESULTATER

Tak, fordi du valgte dette AEG-produkt. Vi har skabt det for at give dig upåklagelig ydeevne i mange år med innovative teknologier, som gør livet lettere – funktioner, som du måske ikke finder på almindelige apparater. Brug et par minutter på at læse mere – så du kan få det bedste ud af det.

Besøg vores hjemmeside for at:



Få rådgivning, brochurer, fejlfinding, service- og reparationsinformation:
www.aeg.com/support



Registrér dit produkt for at få bedre service:
www.registeraeg.com



Køb tilbehør, forbrugsvarer og originale reservedele til dit apparat:
www.aeg.com/shop

KUNDEPLEJE OG SERVICE

Brug altid originale reservedele.

Sørg for at have følgende data klar, når du kontakter vores autoriserede servicecenter: Model, PNC, serienummer.

Oplysningerne findes på typeskiltet.

 Advarsel/forsigtig-sikkerhedsanvisninger

 Generelle oplysninger og råd

 Miljøoplysninger

Ret til ændringer uden varsel forbeholdes.

INDHOLDSFORTEGNELSE

1. OM SIKKERHED	3	3.2 Tilbehør	10
1.1 Sikkerhed for børn og sårbare personer.....	3	4. BETJENINGSPANEL	10
1.2 Generel sikkerhed.....	4	4.1 Oversigt over betjeningspanel.....	10
2. SIKKERHEDSANVISNINGER	5	4.2 Skærm.....	11
2.1 Installation.....	5	5. FØR BRUG FØRSTE GANG	12
2.2 El-forbindelse.....	6	5.1 Indledende rengøring	12
2.3 Brug.....	7	5.2 Første tilslutning.....	12
2.4 Vedligeholdelse og rengøring.....	7	5.3 Indledende forvarmning.....	12
2.5 Pyrolyserengøring.....	8	5.4 Indstil: Vandets hårdhed.....	13
2.6 Tilberedning med kombidamp.....	8	6. DAGLIG BRUG	14
2.7 Indvendig belysning.....	8	6.1 Indstilling: Ovnfunktioner.....	14
2.8 Service.....	9	6.2 Sådan indstilles: - Damp-ovnfunktioner.....	14
2.9 Bortskaffelse.....	9	6.3 Indstilling: Hjælp til tilberedning.....	15
3. PRODUKTBESKRIVELSE	9	6.4 Ovnfunktioner.....	16
3.1 Generelt overblik.....	9	6.5 Bemærkninger til: Fugtig varmluft..	18

7. URFUNKTIONER.....	18	11.5 Anvendelse: Afkalkning.....	29
7.1 Beskrivelse af urfunktioner.....	18	11.6 Påmindelse om afkalkning.....	30
7.2 Indstilling: Urfunktioner.....	19	11.7 Anvendelse: Rensning af dampgenerator.....	31
8. BRUG AF TILBEHØRET.....	20	11.8 Anvendelse: Tømning af vandbeholder.....	31
8.1 Isætning af tilbehør.....	20	11.9	
8.2 Termometer.....	21	Sådan fjerner og installerer du: Låge..	32
8.3 Anvendelse: Termometer.....	21	11.10 Udskiftning: Lampe.....	33
9. EKSTRAFUNKTIONER.....	23	12. FEJLFINDING.....	34
9.1 Sådan gemmer du: Favoritter.....	23	12.1 Hvad gør du, hvis	34
9.2 Panel lås.....	23	12.2 Håndtering: Fejlkode.....	35
9.3 Automatisk slukning.....	23	12.3 Servicedata.....	35
9.4 Køleblæser.....	24	13. ENERGIEFFEKTIV.....	36
10. RÅD OG TIPS.....	24	13.1 Produktoplysninger og produktoplysningsark.....	36
10.1 Anbefalinger til tilberedning.....	24	13.2 Energibesparelse.....	37
10.2 Fugtig varmluft.....	24	14. MENUSTRUKTUR.....	38
10.3 Fugtig varmluft - anbefalet tilbehør.....	25	14.1 Menu.....	38
10.4 Madlavningstabeller for testinstitutter.....	25	14.2 Undermenu for: Rengøring.....	38
11. VEDLIGEHOLDELSE OG RENGØRING.....	27	14.3 Undermenu for: Tilvalg.....	38
11.1 Bemærkninger om rengøring.....	27	14.4 Undermenu for: Opsætning.....	39
11.2 Fjernelse: Ovnribber	28	14.5 Undermenu for: Service.....	39
11.3 Anvendelse: Pyrolyserengøring..	28	15. DET ER NEMT!.....	40
11.4 Husk rengøring.....	29	16. MILJØHENSYN.....	41

1. ⚠️ OM SIKKERHED

Læs brugsanvisningen grundigt, før apparatet installeres og tages i brug. Producenten påtager sig intet ansvar for eventuelle skader, der er resultatet af forkert installation eller brug. Opbevar altid brugsanvisningen på et sikkert og tilgængeligt sted til senere opslag.

1.1 Sikkerhed for børn og sårbare personer

- Apparatet må kun bruges af børn fra 8 år og opefter samt af personer med nedsat fysisk, sensorisk eller psykisk funktionsevne, eller som mangler den nødvendige erfaring eller viden, hvis de er under opsyn eller er blevet instrueret i at bruge apparatet på en sikker måde samt forstår de farer,

det indebærer. Børn under 8 år og personer med omfattende og komplekst handicap skal holdes på afstand af apparatet, medmindre de overvåges konstant.

- Børn skal holdes under opsyn for at sikre, at de ikke leger med apparatet.
- Opbevar al emballage utilgængeligt for børn, og bortskaf det korrekt.
- ADVARSEL: Ovnen og de tilgængelige dele bliver meget varme under brug. Lad ikke børn og husdyr komme tæt på apparatet, mens det er i brug, eller når det køler af.
- Hvis apparatet har en børnesikring, skal den aktiveres.
- Børn må ikke udføre rengøring og vedligeholdelse på produktet uden opsyn.

1.2 Generel sikkerhed

- Dette apparat må kun anvendes til tilberedning af fødevarer.
- Dette apparat er beregnet til indendørs husholdningsbrug.
- Dette apparat kan bruges på kontorer, hotelværelser, bed & breakfast-værelser, stue- og gæstehuse og anden lignende indkvartering, hvor en sådan brug ikke overstiger (gennemsnitlig) brugsniveauer i hjemmet.
- Kun en faguddannet installatør må installere apparatet og udskifte kablet.
- Brug ikke apparatet, inden det monteres i den indbyggede struktur.
- Før enhver vedligeholdelse skal apparatet kobles fra elnettet.
- Hvis strømledningen er beskadiget, skal den af sikkerhedsgrunde udskiftes af producenten, det autoriserede servicecenter eller en tekniker med tilsvarende kvalifikationer.
- ADVARSEL: Sørg for, at der er slukket for apparatet, inden pæren skiftes for at undgå elektrisk stød.

- **ADVARSEL:** Ovn og de tilgængelige dele bliver meget varme under brug. Vær omhyggelig med at undgå at røre ved varmeelementer eller ovnrummets overflade.
- Brug altid ovnhandsker til at fjerne eller isætte tilbehør eller ovnartikler.
- Brug kun den anbefalede temperaturføler (termometer) til dette apparat.
- Træk først ovnribberne og derefter den bageste ende væk fra sidevæggene for at fjerne ovnribberne. Monter ovnribberne i modsat rækkefølge.
- Brug ikke damprensere til at rengøre apparatet.
- Brug ikke skrappe slibende rengøringsmidler eller skarpe metalskrabere til at rengøre glasset i kogesektionens hængslede låg. De kan ridse overfladen, med det resultat, at glasset knuses.
- Fjern al tilbehøret fra rummet i apparatet før pyrolyserengøring.

2. SIKKERHEDSANVISNINGER

2.1 Installation

**ADVARSEL!**

Apparatet må kun installeres af en sagkyndig.

- Fjern al emballagen.
- Undlad at installere eller bruge et beskadiget apparat.
- Følg installationsvejledningen, der følger med apparatet.
- Vær altid forsigtig, når du flytter apparatet, da det er tungt. Brug altid sikkerhedshandsker og lukket fodtøj.
- Træk aldrig i apparatet i håndtaget.
- Installér apparatet et sikkert og velegnet sted, der opfylder installationskrav.
- Mindsteafstanden til andre apparater og enheder skal overholdes.
- Før du monterer ovnen, skal du kontrollere, om ovnlågen åbner uden modstand.
- Apparatet er udstyret med et elektrisk afkølingssystem. Det skal betjenes med den elektriske strømforsyning.
- Indbygningsskabets stabilitet skal opfylde kravene i DIN 68930.

Kabinettets minimumshøjde (kabinets minimumshøjde under bordpladen)	578 (600) mm
---------------------------------------------------------------------	--------------

Kabinet, bredde	560 mm
Kabinet, dybde	550 (550) mm
Højde foran på apparatet	594 mm
Højde bagest på apparatet	576 mm
Bredde foran på apparatet	595 mm
Bredde bagest på apparatet	559 mm
Apparatets dybde	567 mm
Apparatets indbygningsdybde	546 mm
Dybde med åben dør	1027 mm
Ventilationsåbning minimumsstørrelse. Åbning placeret på bundens bageste side	560x20 mm
Længden på ledninger til strømforsyning. Ledning placeret i højre hjørne af bagsiden	1500 mm
Monteringsskruer	4x25 mm

2.2 El-forbindelse



ADVARSEL!

Risiko for brand og elektrisk stød.

- Alle elektriske tilslutninger skal udføres af en kvalificeret elektriker.
- Apparatet skal tilsluttes strøm m/jord, jvf. Stærkstrømsreglementet.
- Sørg for, at parametrene på typeskiltet er kompatible med nettilslutningens elektriske mærkeværdier.
- Brug altid en korrekt monteret lovlig stikkontakt.
- Brug ikke multistikadaptere og forlængerledninger.
- Pas på, du ikke beskadiger netstikket og netledningen. Hvis der bliver behov for at udskifte netledningen, skal det udføres af vores autoriserede servicecenter.
- Elledninger må ikke komme i berøring med eller nær ved apparatets låge, især når det er tændt, eller lågen er varm.
- Beskyttelsen mod elektrisk stød fra strømførende og isolerede dele skal fastgøres, så den ikke kan fjernes uden værktøj.
- Sæt først netstikket i stikkontakten ved installationens afslutning. Sørg for, at der er adgang til elstikket efter installationen.
- Hvis stikkontakten er løs, må du ikke sætte netstikket i.

- Undgå at slukke for apparatet ved at trække i netledningen. Tag altid selve netstikket ud af kontakten.
- Brug kun korrekte isoleringsenheder: Gruppeafbrydere, sikringer (sikringer med skruegevind skal tages ud af fatningen), fejlstrømsrelæer og kontaktorer.
- Apparattets installation skal udføres med et isolationsudstyr, så forbindelsen til lysnettet kan afbrydes på alle poler. Isolationsudstyret skal have en brydeafstand på mindst 3 mm.
- Luk apparatets luge helt, inden du sætter netstikket i stikkontakten.
- Dette apparat er forsynet med et stik og en strømledning.

2.3 Brug



ADVARSEL!

Risiko for personskade, forbrændinger og elektrisk stød eller eksplosion.

- Apparattets specifikationer må ikke ændres.
- Sørg for, at ventilationsåbningerne ikke er blokerede.
- Lad ikke apparatet være uden opsyn under drift.
- Sluk for apparatet efter hver brug.
- Vær forsigtig, når du åbner apparatets låge, hvis apparatet er i brug. Der kan slippe varm luft ud.
- Betjen ikke apparatet med våde hænder, eller når det har kontakt med vand.
- Tryk ikke på den åbne låge.
- Brug ikke apparatet som arbejds- eller frasætningsplads.
- Åbn apparatets låge forsigtigt. Brug af ingredienser med alkohol kan forårsage en blanding af alkohol og luft.
- Lad ikke gnister eller åben ild komme i kontakt med apparatet, når du åbner lågen.
- Læg ikke brændbare produkter eller genstande, der er våde med brændbare produkter i nærheden af eller på apparatet.



ADVARSEL!

Risiko for beskadigelse af apparatet.

- Sådan undgås skader eller misfarvning af emaljen:
 - Stil ikke ovnfaste fade eller andre genstande direkte i apparatet.
 - Læg ikke aluminiumsfolie direkte på bunden af ovnrummet.
 - Hæld ikke vand direkte ind i det varme apparat.
 - Hold ikke fugtige fade og madvarer i apparatet, når du har afsluttet tilberedningen.
 - Vær forsigtig, når du fjerner eller monterer tilbehøret.
- Farveændring af emaljen eller rustfrit stål forringer ikke apparatets ydeevne.
- Brug en bradepande til fugtige kager. Frugtsaft forårsager pletter, der kan være permanente.
- Tilbered altid mad med lågen lukket.
- Hvis apparatet installeres bag et møbelpanel (f.eks. en dør), skal du sørge for, at døren aldrig lukkes, mens apparatet er tændt. Der kan opbygges varme og fugt bag et lukket møbelpanel, hvilket kan forårsage efterfølgende skade på apparatet, huset eller gulvet. Luk ikke møbelpanelet, før apparatet er kølet helt af efter brug.

2.4 Vedligeholdelse og rengøring



ADVARSEL!

Risiko for personskade, brand eller skade på apparatet.

- Sluk for apparatet, og tag stikket ud af kontakten inden vedligeholdelse.
- Kontrollér, at apparatet er kølet af. Der er risiko for, at ovnglasset går i stykker.
- Udskift øjeblikkeligt ovnglassets paneler, hvis de er beskadigede. Kontakt det autoriserede servicecenter.
- Vær forsigtig, når du tager lågen af apparatet. Døren er tung!
- Rengør jævnligt apparatet for at forhindre forringelse af overfladematerialet.
- Rengør apparatet med en fugtig, blød klud. Brug kun neutrale rengøringsmidler. Brug ikke slibende midler, skuresvampe, opløsningsmidler eller metalgenstande.
- Hvis du bruger en ovnspray, skal du følge instruktionerne på dens emballage.

2.5 Pyrolyserengøring



ADVARSEL!

Risiko for personskade / brand / kemiske emissioner (dampe) i pyrolyse-tilstand.

- Inden pyrolytisk rensning og forvarmning skal følgende fjernes fra ovnrummet:
 - Alle madrester, spildt olie og fedt
 - alle udtagelige genstande (herunder hylde, ovnrubber osv., der følger med apparatet), især alle non-stick gryder, pander, plader, redskaber osv.
- Læs omhyggeligt alle anvisninger vedrørende pyrolyserengøring.
- Hold børn væk fra apparatet, mens pyrolyserengøringen er i gang. Ovnen bliver meget varm, og varm luft afgives fra de forreste køleåbninger.
- Pyrolyserengøring er en proces ved høj temperatur, som kan frigive dampe fra madrester og konstruktionsmaterialet. Derfor rådes forbrugerne på det kraftigste til at:
 - Sørg for god udluftning under og efter pyrolyserengøringen.
 - giv god ventilation under og efter den første forvarmning.
- Undgå at spilde eller komme vand på ovnlågen under og efter den pyrolyserengøringen for at undgå at beskadige ovnglassene.
- Dampe fra alle pyrolytiske ovne / madrester som beskrevet er ikke skadelige for mennesker, herunder børn, eller personer med helbredsproblemer.
- Hold kæledyr væk fra apparatet under og efter pyrolyserengøringen og forvarmningen. Små kæledyr (især fugle og krybdyr) kan være meget følsomme over for temperaturændringer og udsendt røg.
- Non-stick-overflader på gryder, pander, bakker, redskaber osv. kan blive beskadiget af pyrolyserengøring ved høj temperatur i pyrolytiske ovne og kan også udgøre en kilde til skadelige dampe på lavt niveau.

2.6 Tilberedning med kombidamp



ADVARSEL!

Risiko for forbrændinger og beskadigelse af apparatet.

- Frigivet damp kan forårsage forbrændinger:
 - Vær forsigtig, når du åbner apparatets låge, når funktionen er tændt. Der kan slippe damp ud.
 - Åbn apparatets låge forsigtigt efter tilberedning med damp.

2.7 Indvendig belysning



ADVARSEL!

Risiko for elektrisk stød.

- Vedrørende lampe(rne) i dette produkt og reservedelslamper, der sælges separat: Disse lamper er beregnet til at modstå ekstreme fysiske forhold i husholdningsapparater, såsom temperatur, vibration, fugt, eller er beregnet til at signalere information om apparatets driftsstatus. De er ikke beregnet til at blive brugt i andre apparater, og de er ikke velegnede til belysning af rum.
- Dette produkt indeholder en lyskilde i energieffektivitetsklasse G.
- Brug kun lamper med de samme specifikationer.

2.8 Service

- Kontakt det autoriserede servicecenter for at få repareret apparatet.
- Brug kun originale reservedele.

2.9 Bortskaffelse



ADVARSEL!

Risiko for personskade eller kvælning.

- Kontakt din genbrugsplads ang. oplysninger om, hvordan produktet bortskaffes korrekt.
- Tag stikket ud af kontakten.
- Klip netledningen af tæt ved apparatet og bortskaf den.
- Fjern lågelåsen for at forhindre, at børn eller kæledyr bliver fanget i apparatet.

3. PRODUKTBEKRIVELSE

3.1 Generelt overblik

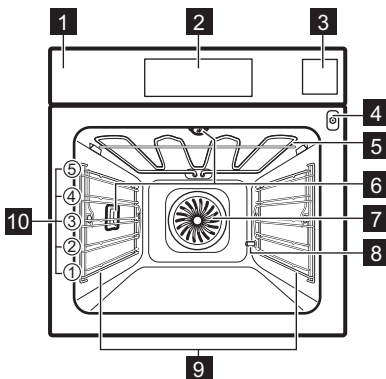

- 1 Betjeningspanel
- 2 Skærm
- 3 Vandbeholder
- 4 Stik til termometer
- 5 Varmelegeme
- 6 Ovnperle
- 7 Blæser
- 8 Afkalkning af afløbsrøret
- 9 Ovnribbe, udtagelig
- 10 Ovnriiler

BETJENINGSPANEL

3.2 Tilbehør

Grillrist

Til kogegrej, kageforme, stege.

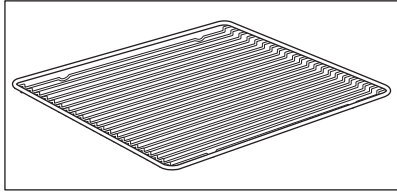

Bageplade

Til kager og småkager.

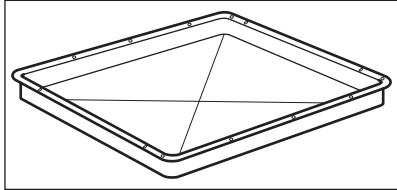

Grill-/bradepande

Til at bage og stege eller som en pande til opsamling af fedt.

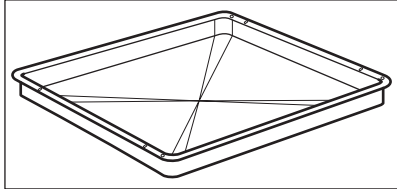

Termometer

Til måling af temperaturen i maden.

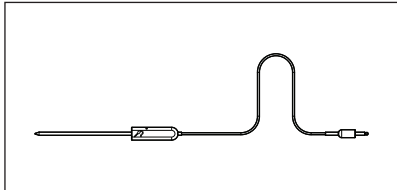

4. BETJENINGSPANEL

4.1 Oversigt over betjeningspanel

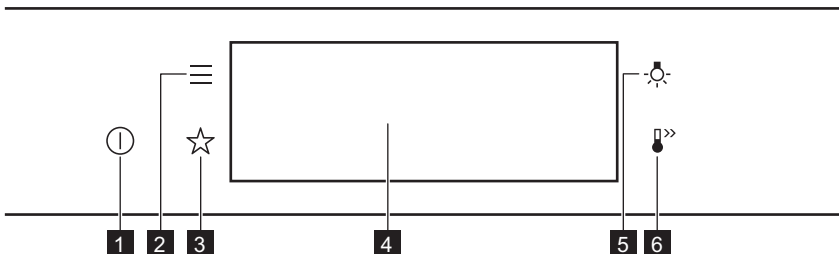



1	TIL / FRA	Tryk og hold nede for at tænde og slukke apparatet.
2	Menu	Angiver apparatets funktioner.
3	Favoritter	Angiver favoritindstillingerne.
4	Skærm	Viser apparatets aktuelle indstillinger.
5	Lampeafbryder	Til at tænde og slukke lampen.
6	Hurtig opvarmning	Til at tænde og slukke funktionen: Hurtig opvarmning.

 Tryk på	 Flyt	 Tryk og hold inde
Rør overfladen med en fingerspids.	Lad fingerspids glide over overfladen.	Rør overfladen i 3 sekunder.

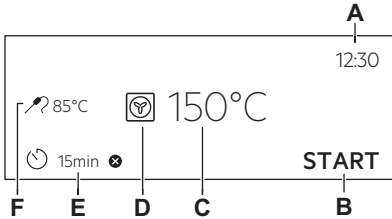



4.2 Skærm

	<p>Display med vigtige funktioner indstillet.</p> <p>A. Aktuel tid B. START/STOP C. Temperatur D. Ovnfunktioner E. Timer F. Termometer (kun udvalgte modeller)</p>
------------------------------------------------------------------------------------	-------------------------------------------------------------------------------------------------------------------------------------------------------------------------------------------------------------------------------------

Displaylamper

Grundlæggende lamper - til navigation på displayet.			
OK For at bekræfte valget/indstillingen.	 For at gå ét niveau tilbage i menuen.	 For at fortryde den sidste handling.	 For at slå tilvalgene til og fra.
Akustisk alarm funktionslamper - når den indstillede tilberedningstid er slut, høres signalet.			

FØR BRUG FØRSTE GANG

 Funktionen er tændt.	 Funktionen er tændt. Tilberedningen stopper automa- tisk.	 Den akustiske alarm sluk- kes.
Timerlamper		
 For at indstille funktionen: Udskudt start.	 For at annullere indstillingen.	

5. FØR BRUG FØRSTE GANG

 ADVARSEL! Se kapitlerne om sikkerhed.

5.1 Indledende rengøring

		
Trin 1	Trin 2	Trin 3
Fjern al tilbehøret fra ovnen og tag de udtagelige ovnrubber ud af ovnen.	Brug kun en mikrofiberklud, varmt vand og et mildt rengøringsmiddel til at rengøre apparatet og tilbehøret, .	Placér tilbehøret og de aftagelige ribber i apparatet.



5.2 Første tilslutning

Displayet viser velkomstmeldelsen efter den første forbindelse.
Du skal indstille: Sprog, Lysstyrke display, Panelsignal, Signal volume, Vandets hårdhed, Aktuell tid.

5.3 Indledende forvarmning





Forvarm den tomme ovn, inden ibrugtagning.

Trin 1	Fjern al tilbehøret fra ovnen og tag de udtagelige ovnrubber ud af ovnen.
Trin 2	Indstil den maksimale temperatur for funktionen:  Lad ovnen være tændt i 1 time.





Trin 3	Indstil den maksimale temperatur for funktionen:  Lad ovnen være tændt i 15 min.
 Ovnen kan udsende lugt og røg under forvarmning. Kontroller, at rummet er udluftet.	

5.4 Indstil: Vandets hårdhed

Når du slutter ovnen til strømnettet for første gang, skal du indstille vandets hårdhedsgrad. Brug testpapiret, eller kontakt dit vandværk for at kontrollere vandets hårdhedsgrad.

			
Trin 1	Trin 2	Trin 3	Trin 4
Læg testpapiret i vand i ca. 1 sek. Anbring ikke testpapiret under rindende vand.	Ryst testpapiret fri for overskydende vand.	Se efter 1 min. vandets hårdhed på nedenstående tabel.	Indstil vandets hårdhedsgrad: Menu / Indstillinger / Opsætning / Vandets hårdhed.
 Testpapirets farver fortsætter med at ændre sig. Kontrollér vandets hårdhed senere end 1 min. efter testen.			
Du kan ændre vandets hårdhedsgrad i menuen: Indstillinger / Opsætning / Vandets hårdhed.			

Tabellen viser vandets hårdhedsgrad (Dh) med det tilsvarende niveau af kalkaflejring og vandklassificering. Juster vandets hårdhedsgrad ifølge tabellen.

Vandets hårdhed		Testpapir	Kalkaflejring (mmol/l)	Kalkaflejring (mg/l)	Vandklassificering
Niveau	dH				
1	0 - 7	 	0 - 1.3	0 - 50	blødt
2	8 - 14		1.4 - 2.5	51 - 100	moderat hårdt
3	15 - 21		2.6 - 3.8	101 - 150	hårdt
4	≥ 22		≥ 3,9	≥ 151	Meget hård

Når vandets hårdhedsgrad er 4, skal du fylde vandbeholderen med flaskevand.

6. DAGLIG BRUG



ADVARSEL!

Se kapitlerne om sikkerhed.

6.1 Indstilling: Ovnfunktioner

Trin 1	Tænd for ovnen. Displayet viser standardovnfunktionen.
Trin 2	Tryk på symbolet for ovnfunktionen for at gå ind i undermenuen.
Trin 3	Vælg varmfunktionen og tryk på: OK. Displayet viser: temperatur.
Trin 4	Indstil: temperatur. Tryk: OK.
Trin 5	Tryk på: START . Termometer - du kan når som helst tilslutte termometeret før eller under tilberedningen.
STOP - tryk for at slukke for ovnfunktionen.	
Trin 6	Sluk for ovnen.

6.2 Sådan indstilles: - Damp-ovnfunktioner

Trin 1	Tænd for ovnen. Vælg symbolet for ovnfunktionen, og tryk på det for at gå ind i undermenuen.
Trin 2	Tryk på  . Indstil dampovnfunktionen.
Trin 3	Tryk på: OK. Displayet viser temperaturindstillingerne.
Trin 4	Indstil temperaturen.
Trin 5	Tryk på: OK.
Trin 6	Tryk på vandbeholderens låg for at åbne den.

Trin 7	<p>Fyld koldt vand i vandbeholderen til det maksimale niveau (ca. 950 ml vand), indtil signalet udsendes, eller displayet viser beskeden. Fyld ikke vandbeholderen til over dens maksimale kapacitet. Der er fare for vandlækage, overløb og møbelskader.</p> <div style="border: 1px solid black; padding: 5px; margin-top: 10px;">  <p>ADVARSEL! Brug kun koldt postevand. Brug ikke filtreret (demineraliseret) eller destilleret vand. Brug ikke andre væsker. Hæld ikke brændbare eller alkoholiske væsker i vandbeholderen.</p> </div>
Trin 8	<p>Skub vandbeholderen til dens oprindelige position.</p>
Trin 9	<p>Tryk på: START . Der kommer damp efter ca. 2 min. Når ovnen når den indstillede temperatur, udsendes et signal.</p>
Trin 10	<p>Når vandbeholderen løber tør for vand, udsendes signalet. Fyld vandbeholderen igen.</p>
Trin 11	<p>Sluk for ovnen.</p>
Trin 12	<p>Tøm vandbeholderen, når tilberedningen med damp ender. Se kapitlet "Vedligeholdelse og rengøring", Tømning af vandbeholder.</p>
Trin 13	<p>Restvand kan kondensere i ovnrummet. Åbn ovnlågen forsigtigt efter tilberedning. Når ovnen er kold, skal du tørre ovnrummet med en blød klud.</p>

6.3 Indstilling: Hjælp til tilberedning



Hver ret i denne undermenu har en anbefalet funktion og temperatur. Du kan justere tiden og temperaturen.

Til nogle retter kan du også tilberede med:

- Vægtautomatik
- Termometer

Den grad, en ret tilberedes ved:

- Rød eller Mindre
- Medium
- Gennemstegt eller Mere









Trin 1	<p>Tænd for ovnen.</p>
Trin 2	<p>Tryk på: </p>
Trin 3	<p>Tryk på:  . Angiv: Hjælp til tilberedning.</p>
Trin 4	<p>Vælg en ret eller en type af madvare.</p>

Trin 5









Tryk på: START .

6.4 Ovnfunktioner



STANDARD

Ovnfunktion	Applikation
 Grillstegning	Til grillstegning af tynde stykker mad og til ristning af brød.
 Turbogrill	Til stegning af større stykker kød eller fjerkræ med ben på én hyldeposition. For at lave gratiner og til at brune.
 Varmluft	Bagning på op til tre ovnriller samtidig og til tørring af fødevarer. Indstil temperaturen 20 - 40°C lavere end ved Over-/undervarme.
 Frosne madvarer	Til tilberedning af sprøde færdigretter (f.eks. pommes frites, kartoffelbåde eller forårsruller).
 Over-/undervarme	Til bagning og stegning af mad på én ovnrille.
 Pizza	Til at bage pizza. Til at lave en kraftig brunning og en sprød bund.
 Undervarme	Til bagning af kager med sprød bund og til henkogning.
 Hævning af dej	For at mindske tiden for hævnings af gærdej. Det forhindrer, at dejoverfladen bliver tør og holder dejen elastisk.

SPECIALPROGRAMMER

Ovnfunktion	Applikation
 <p>Henkogning</p>	Til henkogning af grøntsager (f.eks. pickles).
 <p>Tørring</p>	Til tørring af skåret frugt, grøntsager og champignoner.
 <p>Tallerkenvarmer</p>	Til at forvarme tallerkener til servering.
 <p>Optøning</p>	Til optøning af mad (grøntsager og frugt). Optøningstiden afhænger af mængde og omfang af de de frosne madvarer.
 <p>Gratiner</p>	Til retter som lasagne eller kartoffelgratin. For at lave gratiner og til at brune.
 <p>Slow Cooking</p>	Til tilberedning af møre, saftige stege.
 <p>Holde varm</p>	Til at holde maden varm.
 <p>Fugtig varmluft</p>	Denne funktion er beregnet til at spare energi under madlavning. Når du bruger denne funktion, kan temperaturen i ovnrummet variere fra den indstillede temperatur. Restvarmen anvendes. Varmeeffekten kan blive reduceret. Få flere oplysninger i kapitlet "Daglig brug", Bemærkninger til: Fugtig varmluft.

DAMP

Ovnfunktion	Applikation
 Opvarmning med damp	Genopvarmning af mad med damp forhindrer udtørring af overfladen. Varme fordeles på en mild og jævn måde, hvilket giver mulighed for at gen-danne madens smag og aroma, som da den blev tilberedt. Denne funktion kan bruges til genopvarmning af maden direkte på en tallerken. Du kan genopvarme flere tallerkener ad gangen ved at bruge flere ovnrubber.
 Brød	Brug denne funktion til at bage brød og småt gærbrød med en sprødhed, farve og glans, som var de bagt af en professionel bager.
 Fugtighed lav	Funktionen er egnet til kød, fjerkræ, ovnretter og sammenkogte retter. Takket være kombinationen af damp og varme får kød en mør og saftig konsistens og en sprød skorpe.

6.5 Bemærkninger til: Fugtig varmluft

Denne funktion blev anvendt til at overholde kravene i energieffektivitetsklasse og økodesign (i overensstemmelse med EU 65/2014 og EU 66/2014). Tests i overensstemmelse med: IEC/EN 60350-1

Ovnlågen skal være lukket under tilberedningen, så funktionen ikke afbrydes, og ovnen kører med den højeste energieffektivitet, der er mulig.

Når du bruger denne funktion, slukkes lampen automatisk efter 30 sekunder.

Se kapitlet "Råd" for at få oplysninger om tilberedning, Fugtig varmluft. Se kapitlet "Energieffektivitet", Energibesparelse for generelle anbefalinger til energibesparelse.

7. URFUNKTIONER

7.1 Beskrivelse af urfunktioner

Urfunktioner	Applikation
Tilberedningstid	Indstilling af tilberedningslængden. Maksimum er 23 t 59 min.
Afslut handling	For at indstille hvad der sker, når timeren ophører med at tælle.
Udskudt start	For at udskyde starten og/eller tilberedningens afslutning.
Forlængelse af tid	For at forlænge tilberedningstiden.
Påmindelse	Bruges til at indstille en nedtælling. Maksimum er 23 t 59 min. Denne funktion har ikke indflydelse på ovnen.

Urfunktioner	Applikation
Optimer	Overvåger, hvor længe funktionen er i gang. Optimer - du kan tænde og slukke den.

7.2 Indstilling: Urfunktioner

Indstilling af uret	
Trin 1	Tryk på: Aktuel tid.
Trin 2	Indstil tid. Tryk på: OK.

Indstilling af tilberedningstid	
Trin 1	Vælg ovnfunktion og indstil temperaturen.
Trin 2	Tryk på:  .
Trin 3	Indstil tid. Tryk på: OK.

Sådan vælges tilvalg for sluttid	
Trin 1	Vælg ovnfunktion og indstil temperaturen.
Trin 2	Tryk på:  .
Trin 3	Indstil tilberedningstiden.
Trin 4	Tryk: ● ● ● .
Trin 5	Tryk på: Afslut handling.
Trin 6	Vælg den foretrukne: Afslut handling.
Trin 7	Tryk på: OK. Gentag handlingen, indtil displayet viser hovedskærmen.

BRUG AF TILBEHØRET

Sådan udsættes tilberedningsstarten

Trin 1	Indstil en ovnfunktion og temperaturen.
Trin 2	Tryk på:  .
Trin 3	Indstil tilberedningstiden.
Trin 4	Tryk: ● ● ● .
Trin 5	Tryk på: Udskudt start.
Trin 6	Vælg værdien.
Trin 7	Tryk på: OK. Gentag handlingen, indtil displayet viser hovedskærmen.

Forlængelse af tilberedningstid

Når der er 10% tilberedningstid tilbage, og maden ikke lader til at være klar, kan du forlænge tilberedningstiden. Du kan også ændre ovnfunktionen.

Tryk på **+1min** for at forlænge tilberedningstiden.

Ændring af timerindstillinger

Trin 1	Tryk på:  .
Trin 2	Indstil timerværdien.
Trin 3	Tryk på: OK.

Du kan ændre den indstillede tid under tilberedning når som helst.

8. BRUG AF TILBEHØRET



ADVARSEL!

Se kapitlerne om sikkerhed.

8.1 Isætning af tilbehør

En lille fordybning i toppen øger sikkerheden. Fordybningerne er også antivippe-anordninger. Den høje kant rundt om hylden forhindrer kogegrej i at glide af hylden.

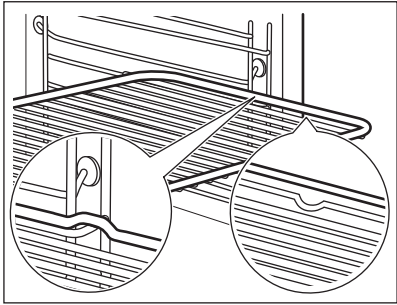
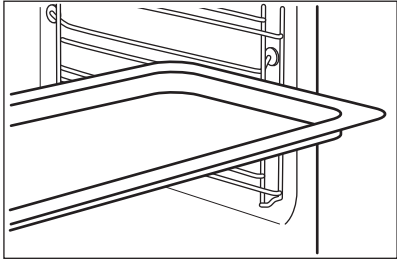
<p>Grillrist: Skub risten mellem ovnribbens skinner, .</p>	
<p>Bageplade / Dyb bradepande: Skub den dybe bradepande ind mellem ovnribbens skinner.</p>	

8.2 Termometer

Termometer - måler temperaturen i maden. Du kan bruge det med hver ovnfunktion.

Der skal indstilles to temperaturer:	
<p>°C Ovntemperaturen: mindst 120 °C.</p>	<p> Kernetemperaturen.</p>



For de bedste madlavningsresultater:		
<p>Ingredienserne bør være ved stuetemperatur.</p>	<p>Brug den ikke til flydende retter.</p>	<p>Under tilberedning skal det forblive i retten.</p>

Ovnen beregner en omtrentlig afslutning af tilberedningstiden. Den afhænger af mængden af mad, den indstillede ovnfunktion og temperaturen.

8.3 Anvendelse: Termometer

<p>Trin 1</p>	<p>Tænd for ovnen.</p>
<p>Trin 2</p>	<p>Vælg en ovnfunktion og evt. ovntemperatur.</p>

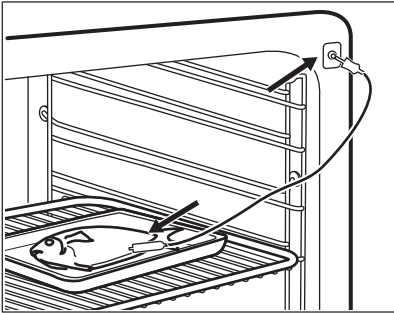
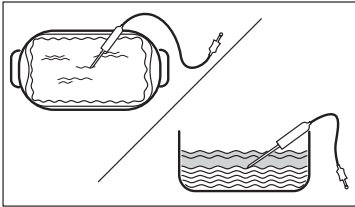

BRUG AF TILBEHØRET

Trin 3	Indsæt: Termometer.
Kød, fjerkræ og fisk	Sammenkogte retter
<p>Indsæt spidsen af Termometer i midten af kød, fisk, om muligt i den tykkeste del. Sørg for, at mindst 3/4 af Termometer er inde i retten.</p>	<p>Indsæt spidsen af Termometer lige midt i gryden. Termometer bør stabiliseres ét sted under bagning. Brug en fast ingrediens til at opnå dette. Brug stegefadets kant til at understøtte termometerets Termometer. Spidsen af Termometer må ikke berøre bunden af et stegefad.</p>
	
Trin 4	<p>Stik: Termometer i stikket på ovnens forside. Displayet viser den aktuelle temperatur af: Termometer.</p>
Trin 5	<p> - tryk for at indstille termometerets kerntemperatur.</p>
Trin 6	<p>• • • - tryk for at indstille den foretrukne valgmulighed:</p> <ul style="list-style-type: none"> • Akustisk alarm - når maden når den indstillede kerntemperatur, udsendes et signal. • Akustisk alarm og stop tilberedning - når maden når den indstillede kerntemperatur, udsendes et signal, og ovnen stopper.
Trin 7	<p>Vælg muligheden og tryk gentagne gange på: OK for at gå til hovedskærmen.</p>
Trin 8	<p>Tryk på: START . Når maden når den indstillede temperatur, udsendes et signal. Du kan vælge at stoppe eller fortsætte tilberedningen for at sikre, at maden er gennemstegt.</p>
Trin 9	<p>Fjern Termometer stikket ud af stikket, og tag retten ud af ovnen.</p> <div style="border: 1px solid black; padding: 5px; margin-top: 10px;"> <p> ADVARSEL! Der er risiko for forbrænding. Termometer bliver varm. Pas på, når du trækker det ud og fjerner det fra maden.</p> </div>

9. EKSTRAFUNKTIONER



9.1 Sådan gemmer du: Favoritter

Du kan gemme dine favoritindstillinger, som f.eks. ovnfunktionen, tilberedningstiden, temperaturen eller rengøringsfunktionen. Du kan gemme 3 favoritindstillinger.

Trin 1	Tænd for apparatet.
Trin 2	Vælg den foretrukne indstilling.
Trin 3	Tryk på:  . Vælg: Favoritter.
Trin 4	Vælg: Gem aktuelle indstillinger.
Trin 5	Tryk på + for at føje indstillingen til listen over: Favoritter. Tryk på OK.
<p> - tryk for at nulstille indstillingen.</p> <p> - tryk for at annullere indstillingen.</p>	



9.2 Panel lås



Denne funktion forhindrer en utilsigtet ændring af ovnfunktionen.

Trin 1	Tænd for apparatet.
Trin 2	Indstil en ovnfunktion.
Trin 3	 ,  - tryk samtidigt for at aktivere funktionen.
Gentag trin 3 for at slå funktionen fra.	

9.3 Automatisk slukning

Af sikkerhedsgrunde slukkes ovnen efter nogen tid, hvis en ovnfunktion er i gang, og du ikke ændrer nogen af indstillingerne.

 (°C)	 (t)
30 - 115	12.5
120 - 195	8.5
200 - 245	5.5

 (°C)	 (t)
250 - maksimum	3

Den automatiske slukning virker ikke med funktionerne: Lys, Termometer, Sluttid, Slow Cooking.

9.4 Køleblæser

Når ovnen er tændt, tændes køleblæseren automatisk for at holde ovnens overflader kølige. Hvis du slukker for ovnen, kan køleblæseren fortsætte med at køre, indtil ovnen køler ned.





10. RÅD OG TIPS





10.1 Anbefalinger til tilberedning

<p>Tabellernes temperaturer og tilberedningstider er kun vejledende. De afhænger af opskrifterne og kvaliteten og mængden af de anvendte ingredienser.</p> <p>Din ovn bager eller steger muligvis anderledes end den ovn, du havde før. Rådene herunder viser anbefalede indstillinger for temperatur, tilberedningstid og hyldeposition for specifikke typer mad.</p> <p>Hvis du ikke kan finde indstillinger til en speciel opskrift, kan du se efter en lignende.</p> <p>Få flere tilberedningsanbefalinger i madlavningstabellerne på vores website. For at finde madlavningstips skal du kontrollere PNC-nummeret på typeskiltet på forsiden af ovnrummet.</p>

10.2 Fugtig varmluft



For at få de bedste resultater skal du følge forslagene angivet på nedenstående tabel.

		 (°C)		 (min.)
Søde boller, 16 stk.	bageplade eller bradepande	180	2	25 - 35
Roulade	bageplade eller bradepande	180	2	15 - 25
Hel fisk, 0,2 kg	bageplade eller bradepande	180	3	15 - 25

		 (°C)		 (min.)
Småkager, 16 stk.	bageplade eller bradepande	180	2	20 - 30
Makroner, 24 stk.	bageplade eller bradepande	160	2	25 - 35
Muffins, 12 stk.	bageplade eller bradepande	180	2	20 - 30
Madtærte, 20 stk.	bageplade eller bradepande	180	2	20 - 30
Småkager af mørdej, 20 stk.	bageplade eller bradepande	140	2	15 - 25
Små tærter, 8 stk.	bageplade eller bradepande	180	2	15 - 25

10.3 Fugtig varmluft - anbefalet tilbehør

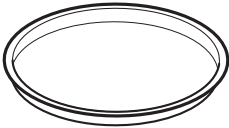
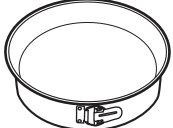
Brug mørke og ikke-reflekterende former og beholdere. De har en bedre varmeabsorbering end lyse og reflekterende fade.

			
Pizzaform	Bageform	Ramekiner	Tærtebundform
Mørk, ikke-reflekterende 28 cm diameter	Mørk, ikke-reflekterende 26 cm diameter	Keramisk 8 cm diameter, 5 cm højde	Mørk, ikke-reflekterende 28 cm diameter





10.4 Madlavningstabeller for testinstitutter

Information til testinstitutter





Tests i overensstemmelse med: EN 60350, IEC 60350.

RÅD OG TIPS





Bagning i ét lag - bagning i forme

		 °C	 min	
Fedtfattig sandkage	Varmluft	160	45 - 60	2
Fedtfattig sandkage	Over-/undervarme	160	45 - 60	2
Æbletærte, 2 forme Ø20 cm	Varmluft	160	55 - 65	2
Æbletærte, 2 forme Ø20 cm	Over-/undervarme	180	55 - 65	1
Smørkager	Varmluft	140	25 - 35	2
Smørkager	Over-/undervarme	140	25 - 35	2





Bagning i ét lag - lagkagebunde Brug den tredje ovenrille.

		 °C	 min
Små kager i form, 20 stk./plade, forvarm den tomme ovn	Varmluft	150	20 - 30
Små kager i form, 20 stk./plade, forvarm den tomme ovn	Over-/undervarme	170	20 - 30

Bagning i flere lag - lagkagebunde

		 °C	 min	
Smørkager	Varmluft	140	25 - 45	2 / 4
Små kager i form, 20 stk./plade, forvarm den tomme ovn	Varmluft	150	25 - 35	1 / 4





VEDLIGEHOVELSE OG RENGØRING

		 °C	 min	
Fedtfattig sandkage	Varmluft	160	45 - 55	2 / 4
Æbletærte, 1 form pr. rist (Ø 20 cm)	Varmluft	160	55 - 65	2 / 4

Grill

Forvarm den tomme ovn i 5 minutter.

Grill med den maksimale temperaturindstilling.

		 min	
Toast	Grillstegning	1 - 2	5
Oksesteak, vendes undervejs	Grillstegning	24 - 30	4



11. VEDLIGEHOVELSE OG RENGØRING



ADVARSEL!

Se kapitlerne om sikkerhed.

11.1 Bemærkninger om rengøring

 Rengørings- midler	Rengør ovnens front med en mikrofiberklud med varmt vand og et mildt rengøringsmiddel.
	Brug en rengøringsmiddelopløsning til at rengøre metaloverflader.
	Rengør pletter med et mildt rengøringsmiddel.
 Hverdags- brug	Rengør altid ovnrummet efter brug. Ophobning af fedt eller andre rester kan forårsage brand.
	Opbevar ikke madvarer i ovnen i mere end 20 minutter. Ovnrummet tørres kun med en mikrofiberklud efter hver brug.



Tilbehør

Rengør alt tilbehør efter hver brug, og lad det tørre. Brug en mikrofiberklud med varmt vand og et mildt rengøringsmiddel. Tilbehøret må ikke vaskes i opvaske-maskinen.

Rengør ikke non stick-tilbehøret med slibende rengøringsmiddel eller genstan-de med skarpe kanter.

11.2 Fjernelse: Ovnribber

Fjern ovnribberne, så ovnen kan rengøres.

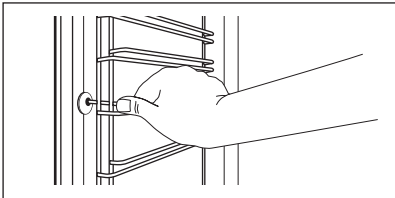
Trin 1	Sluk for ovnen, og vent, til den er kold.	
Trin 2	Træk forsigtigt ovnribberne op-ad og ud af det forreste op-hæng.	
Trin 3	Træk forenden af ribben væk fra sidevæggen.	
Trin 4	Træk holderne ud af baglåsen.	
Montér ovnribberne i modsat rækkefølge.		

11.3 Anvendelse: Pyrolyserengøring

Rengør ovnen med Pyrolyserengøring.



ADVARSEL!

Der er risiko for forbrænding.



FORSIGTIG!

Hvis der er andre apparater installeret i det samme skab, bør de ikke bruges samtidig med denne funktion. Det kan skade ovnen.

Før Pyrolyserengøring:

Sluk for ovnen, og vent, til den er kold.	Fjern al tilbehøret fra ovnen.	Rengør ovnbunden og det indvendige lågegias med varmt vand, en blød klud og et mildt rengøringsmiddel.
-------------------------------------------	--------------------------------	--------------------------------------------------------------------------------------------------------

Fyld ikke vandtanken under rengøring. Den genstarter rengøringscyklussen.

Trin 1	Tænd for ovnen.
---------------	-----------------

Trin 2	Tryk på:  / Rengøring.	
Trin 3	Stil bagepladen på den første ovnrille for at opsamle vand fra vandbeholderen. OK – tryk for at starte tømning af vandbeholder.	
Trin 4	Når tømningen af beholderen ender, skal du fjerne bagepladen og de udtagelige ovnrubber. Tør ovnrummet og det indvendige rudeglas af med en blød klud. Tryk: OK .	
Trin 5	Vælg rengøringstilstanden.	
Valgmulighed	Rengøringstilstand	Varighed
Pyrolyserengøring, kort	Let rengøring	1 h
Pyrolyserengøring, normal	Normal rengøring	1 h 30 min
Pyrolyserengøring, intens	Grundig rengøring	3 h
<p>i Når rengøringen starter, er lampen slukket, og blæseren virker ved en højere hastighed. STOP – tryk for at stoppe rengøringen, før den er færdig. Brug ikke ovnen, før lågelås-symbolet forsvinder fra displayet.</p>		

Når rengøringen slutter:

Sluk for ovnen, og vent, til den er kold.	Rengør ovnrummet med en blød klud.	Fjern resterne fra bunden af ovnrummet.
-------------------------------------------	------------------------------------	-----------------------------------------

11.4 Husk rengøring

Når påmindelsen vises, anbefales rengøring.
Brug funktionen: Pyrolyserengøring.

11.5 Anvendelse: Afkalkning

Inden start:		
Sluk for ovnen, og vent, til den er kold.	Fjern al tilbehøret fra ovnen.	Sørg for, at vandbeholderen er tom.

VEDLIGEHOJDELSE OG RENGØRING

Varighed af den første del: ca. 100 min	
Trin 1	Stil bradepanden på ovnens første rille.
Trin 2	Hæld 250 ml afkalkningsmiddel i vandbeholderen.
Trin 3	Kom vand i den resterende del af vandbeholderen til det maksimale niveau, indtil signalet udsendes, eller displayet viser beskeden.
Trin 4	Vælg: Menu / Rengøring.
Trin 5	Tænd for funktionen, og følg instruktionen på displayet. Den første del af afkalkningen starter.
Trin 6	Når den første del er afsluttet, skal bradepanden tømmes og sættes tilbage i den første rille.
Varigheden af den anden del: ca. 35 min	
Trin 7	Kom vand i den resterende del af vandbeholderen til det maksimale niveau, indtil signalet udsendes, eller displayet viser beskeden.
Trin 8	Fjern bradepanden, når funktionen ender.
 Når denne funktion virker, er lyset slukket.	

Når afkalkningen er færdig:		
Sluk for ovnen.	Når ovnen er kold, skal du tørre ovnrummet med en blød klud.	Lad ovnens låge være åben og vent, indtil ovnrummet er tørt.
 Hvis der er nogle kalkrester tilbage i ovnen efter afkalkning, beder displayet om at gentage proceduren.		

11.6 Påmindelse om afkalkning

Der er to påmindelser, der husker dig på at afkalke ovnen. Du kan ikke deaktivere huskefunktionen til afkalkning.

Type	Beskrivelse
Blød påmindelse	Anbefaler dig at afkalke ovnen.

Type	Beskrivelse
Hård påmindelse	Forpligter dig til at afkalke ovnen. Hvis du ikke afkalke ovnen, når den hårde påmindelse er aktiv, bliver dampfunktionerne deaktiveret.

11.7 Anvendelse: Rensning af dampgenerator

Inden start:	
Sluk for ovnen, og vent, til den er kold.	Fjern al tilbehøret fra ovnen.
Trin 1	Stil bradepanden på ovnens første rille.
Trin 2	Kom vand i vandbeholderen til det maksimale niveau, indtil signalet udsendes, eller displayet viser beskeden.
Trin 3	Vælg: Menu / Rengøring / Rensning af dampgenerator. Varighed: ca. 30 min
Trin 4	Tænd for funktionen, og følg instruktionen på displayet.
Trin 5	Fjern bradepanden, når funktionen ender.
 Når denne funktion virker, er lyset slukket.	

11.8 Anvendelse: Tømning af vandbeholder

Brug den efter tilberedning med dampovnfunktion til at fjerne det resterende vand fra vandbeholderen.

Inden start:	
Sluk for ovnen, og vent, til den er kold.	Fjern al tilbehøret fra ovnen.
Trin 1	Stil bradepanden på ovnens første rille.
Trin 2	Vælg: Menu / Rengøring / Tømning af vandbeholder. Varighed: 6 min.
Trin 3	Tænd for funktionen, og følg instruktionen på displayet.
Trin 4	Fjern bradepanden, når funktionen ender.

i Når denne funktion virker, er lyset slukket.

11.9 Sådan fjerner og installerer du: Låge

Du kan tage lågen og det indvendige ovnglas ud for at rengøre det. Antallet af glaspaneler er forskelligt for forskellige modeller.



ADVARSEL!
Døren er tung.



FORSIGTIG!
Hånder forsigtigt glasset, især omkring frontpanelets kanter. Glasset kan gå i stykker.

Trin 1	Åbn lågen helt.	
Trin 2	Løft og tryk låsegrebene (A) helt på de to lågehængsler.	
Trin 3	Sæt ovnlågen i den første tætte position (vinkel på ca. 70°). Hold lågen i begge sider, og træk den væk fra ovnen i en vinkel opad. Læg lågen med ydersiden nedad på en blød klud på et stabilt underlag.	
Trin 4	Hold i begge sider af lågelisten (B) i lågens overkant, og tryk indad, indtil låsehagen slipper.	
Trin 5	Træk lågelisten fremad, og tag den ud.	
Trin 6	Hold i overkanten af hvert enkelt ovnglas, og træk det opad og ud af skinnen.	

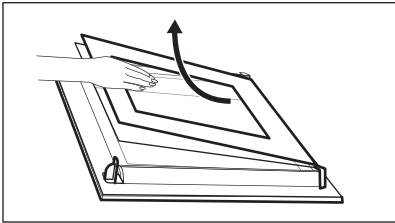
Trin 7	Rengør glaspanelet med vand og sæbe. Tør ovnglasset forsigtigt. Ovnglasset må ikke komme i opvaskemaskinen.	
Trin 8	Udfør ovennævnte trin i omvendt rækkefølge efter rengøring.	
Trin 9	Sæt det mindste glas i først og derefter det største og lågen.	

11.10 Udskiftning: Lampe



ADVARSEL!

Risiko for elektrisk stød
Pæren kan være varm.

Før du udskifter pæren:

Trin 1	Trin 2	Trin 3
Sluk for ovnen. Vent, til ovnen er kold.	Tag stikket ud af kontakten.	Læg en klud i bunden af ovnrummet.

Toplampe

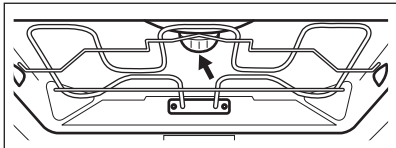
Trin 1	Drej glasset, og tag det af.	
Trin 2	Fjern metalringen og rengør glassdækslet.	
Trin 3	Udskift pæren med en passende 300 °C varrefast pære.	
Trin 4	Fastgør metalringen til glassdækslet og installer den.	

Sidelampe

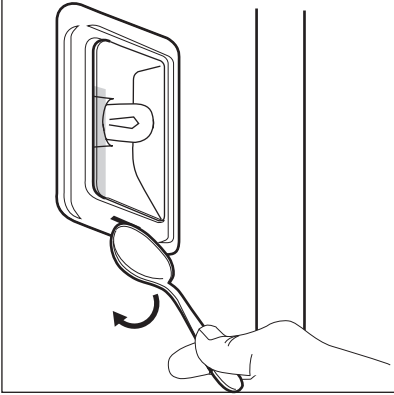
Trin 1	Fjern den venstre hyldestøtte for at få adgang til pæren.	
Trin 2	Brug en smal, stump genstand (f.eks. en teske) til at fjerne glasdækslet.	
Trin 3	Rengør glasdækslet.	
Trin 4	Udskift pæren med en passende 300 °C varmefast pære.	
Trin 5	Montér glasdækslet.	
Trin 6	Montér venstre hyldestøtte.	



12. FEJLFINDING









ADVARSEL!

Se kapitlerne om sikkerhed.

12.1 Hvad gør du, hvis ...

 Apparatet tænder ikke eller bliver ikke varmt	
 Mulig årsag	 Afhjælpning
Apparatet er ikke tilsluttet lysnettet, eller også er det tilsluttet forkert.	Kontrollér, om apparatet er tilsluttet korrekt til lysnettet.
Uret er ikke indstillet.	Indstil uret. For yderligere oplysninger henvises til Urfunktioner kapitel, Sådan indstilles: Urfunktioner.
Lågen er ikke lukket korrekt.	Luk lågen helt.
Sikringen er sprunget.	Tjek, om problemet skyldes en defekt sikring. Hvis problemet forekommer igen, bedes du kontakte en kvalificeret elektriker.



 Apparatet tænder ikke eller bliver ikke varmt	
 Mulig årsag	 Afhjælpning
Apparatet Børnesikring er tændt.	Se kapitlet "Menu", Undermenu for: Tilvalg.

 Komponenter	
 Beskrivelse	 Afhjælpning
Pæren er sprunget.	Udskift pæren. Se detaljer i kapitlet "Vedligeholdelse og rengøring", Udskiftning: Ovnpære.

Strømafbrydelse stopper altid rengøring. Gentag rengøringen, hvis den afbrydes af strømafbrydelse.

12.2 Håndtering: Fejlkode

Når softwarefejlen opstår, viser displayet en fejlmeddelelse. I dette afsnit finder du listen over de problemer, du selv kan håndtere.

 Kode og beskrivelse	 Afhjælpning
C2 - Termometer er i ovnrummet under Pyrolyserengøring.	Fjern Termometer.
C3 - lågen er ikke helt lukket under Pyrolyserengøring.	Luk lågen.
F111 - Termometer er ikke sat rigtigt i stikkontakten.	Sæt Termometer ind i stikket.
F240, F439 - berøringselementerne på displayet virker ikke korrekt.	Rengør displayets overflade. Sørg for, at der ikke er snavs på berøringselementerne.
F908 - ovnsystemet kan ikke oprette forbindelse til kontrolpanelet.	Sluk og tænd for ovnen.

12.3 Servicedata

Kontakt din forhandler eller et autoriseret servicecenter, hvis du ikke selv kan løse problemet.

ENERGIEFFEKTIV

De nødvendige oplysninger til servicecenteret er angivet på maskinens typeskilt. Typeskiltet sidder på ovnsens frontramme. Typeskiltet må ikke fjernes fra ovnrummet.

Det anbefales, at du noterer oplysningerne her:	
Model (MOD.)
Produktnummer (PNC)
Serienummer (S.N.)

13. ENERGIEFFEKTIV

13.1 Produktoplysninger og produktoplysningsark

Leverandørens navn	AEG
Identifikation af model	BSE77280M 944188685 BSE77228BM 944188655 BSK772280M 944188643 BSS772280B 944188644
Energieffektivitetsindeks	61.2
Energieffektivitetsklasse	A++
Energiforbrug med en standardmængde, almindelig tilstand	1.09 kWh/cyklus
Energiforbrug med en standardmængde, blæsertvungen tilstand	0.52 kWh/cyklus
Antal ovnrum	1
Varmekilde	Elektricitet
Lydstyrke	71 l
Type ovn	Indbygningsovn

Vægt	BSE772280M	36.0 kg
	BSE77228BM	36.0 kg
	BSK772280M	36.0 kg
	BSS772280B	36.0 kg

IEC/EN 60350-1 - Elektriske husholdningsapparater til madlavning - Del 1: Komfurer, ovne, damp-ovne og grillapparater - Metoder til måling af ydeevne.

13.2 Energibesparelse



Apparatet indeholder funktioner, som hjælper dig med at spare energi ved daglig madlavning.

Sørg for, at ovnsens låge er lukket, når ovnen er tændt. Åbn ikke ovnlågen for ofte under tilberedningen. Hold dørpakningen ren og sørg for, at den sidder godt fast.

Brug køkkengrej af metal for at øge energibesparelsen.

Forvarm om muligt ikke ovnen inden tilberedning.

Hold pauserne mellem bagning så korte som muligt, når du tilbereder nogle få retter på én gang.

Tilberedning med blæser

Brug om muligt tilberedningsfunktionerne med blæser for at spare energi.

Restvarme

Hvis et program med Varighed er aktiveret, og tilberedningstiden er længere end 30 minutter, slukkes varmelegemerne automatisk tidligere i nogle apparatfunktioner.

Blæseren og lampen bliver ved med at være tændt. Når du tænder for ovnen, viser displayet eftervarmen. Du kan bruge varmen til at holde maden varm.

Når tilberedningsvarigheden er længere end 30 min., skal du reducere ovntemperaturen til minimum 3 - 10 min. inden tilberedningen er slut. Eftervarmen i ovnen vil blive ved med at tilberede maden.

Brug restvarmen til at opvarme andre retter.

Hold maden varm

Vælg den lavest mulige temperaturindstilling for at bruge restvarme og holde et måltid varmt. Restvarmelampen eller temperaturen vises på displayet.

Tilberedning med slukket lampe

Sluk for lampen under tilberedning. Tænd kun for det, når det er nødvendigt.

Fugtig varmluft

Denne funktion er beregnet til at spare energi under madlavning.

Når du bruger denne funktion, slukkes lampen automatisk efter 30 sekunder. Du kan tænde det igen, men denne handling vil mindske den forventede energibesparelse.

14. MENUSTRUKTUR

14.1 Menu

Menupunkt		Applikation
Hjælp til tilberedning		Angiver automatiske programmer.
Rengøring		Angiver rengøringsprogrammer.
Favoritter		Angiver favoritindstillingerne.
Tilvalg		For at indstille ovnkonfigurationen.
Indstillinger	Opsætning	For at indstille ovnkonfigurationen.
	Service	Viser softwarens version og konfiguration.

14.2 Undermenu for: Rengøring

Undermenu	Applikation
Tømning af vandbeholder	Fremgangsmåde for at fjerne restvandet fra vandbeholderen efter brug af dampfunktionerne.
Pyrolyserengøring, kort	Varighed: 1 h.
Pyrolyserengøring, normal	Varighed: 1 h 30 min.
Pyrolyserengøring, intens	Varighed: 3 h.
Afkalkning	Procedure for rengøring af dampkredsløbet for kalk.
Rensning af dampgenerator	Procedure til rensning og rengøring af dampkredsløbet efter hyppig brug af dampfunktionerne.

14.3 Undermenu for: Tilvalg

Undermenu	Applikation
Lys	Slår lampen til og fra.

Undermenu	Applikation
Børnesikring	Forhindrer utilsigtet aktivering af ovnen. Når tilvalget er slået til, vises teksten Børnesikring på displayet, når du tænder for apparatet. For at aktivere brugen af ovnen skal du vælge kodebogstaverne i alfabetisk rækkefølge. Når tilvalget er slået til, og apparatet er slukket, er apparatets låge låst. Adgang til timeren, fjernbetjent tilstand og pæren er mulig med tilvalget slået til.
Hurtig opvarmning	Afkorter opvarmningstiden. Den er kun tilgængelig for nogle af ovnens funktioner.
Tidsangivelse	Slår uret til og fra.
Digitalt ur	Ændrer formatet på den viste tid.

14.4 Undermenu for: Opsætning

Undermenu	Beskrivelse
Sprog	Indstiller ovnens sprog.
Lysstyrke display	Indstiller displayets lysstyrke
Panelsignal	Aktiverer og deaktiverer tonen i berøringsfelterne. Lydsignalet kan ikke slås fra for: ①.
Signal volume	Indstiller lydstyrken af tastetoner og signaler.
Vandets hårdhed	Indstiller vandets hårdhed.
Aktuel tid	Indstiller den aktuelle tid og dato.

14.5 Undermenu for: Service

Undermenu	Beskrivelse
Demo funktion	Aktiverings- / deaktiveringskode: 2468
Softwareversion	Oplysninger om softwareversion.

DET ER NEMT!

Undermenu	Beskrivelse
Nulstil alle indstillinger	Gendanner fabriksindstillingerne.

15. DET ER NEMT!

Inden den første anvendelse skal du indstille:

Sprog	Lysstyrke display	Panelsignal	Signal volume	Vandets hårdhed	Aktuel tid
-------	-------------------	-------------	---------------	-----------------	------------

Start med at bruge ovnen



Hurtig start		Trin 1	Trin 2	Trin 3
	Tænd for ovnen og begynd tilberedningen med funktionens standardtemperatur og -tid.	Tryk på og hold: ①.	 ... - vælg den foretrukne funktion.	Tryk på: START .
Hurtigt sluk	Sluk for ovnen, enhver skærm eller meddelelse, til enhver tid.	① - tryk og hold nede, indtil ovnen slukker.		

Start tilberedning

Trin 1	Trin 2	Trin 3	Trin 4	Trin 5
① - tryk for at tænde ovnen.	 ... - vælg ovnfunktionen.	°C - indstil temperaturen.	OK - tryk for at bekræfte.	START - tryk for at starte tilberedning.

Lær at tilberede mad hurtigt

Brug de automatiske programmer for at tilberede en ret hurtigt med standardindstillingerne:



Hjælp til tilberedning	Trin 1	Trin 2	Trin 3	Trin 4
	Tryk: ①.	Tryk på:  .	Tryk:  Hjælp til tilberedning.	Vælg retten.

Brug hurtigfunktioner til at indstille tilberedningstiden**10% Finish assist**

Brug 10% Finish assist til at forlænge tiden, når der er 10% af tilberedningstiden er tilbage.

Forlæng tilberedningstiden ved at trykke på **+1min.**

16. MILJØHENSYN

Genbrug materialer med symbolet . Anbring emballagematerialet i passende beholdere til genbrug. Hjælp med at beskytte miljøet og menneskelig sundhed samt at genbruge affald af elektriske og elektroniske apparater. Kasser ikke apparater, der er mærket med symbolet , sammen med husholdningsaffaldet. Lever produktet tilbage til din lokale genbrugsplads eller kontakt din kommune.

VOOR PERFECTE RESULTATEN

Bedankt dat je voor dit AEG-product hebt gekozen. We hebben het gecreëerd om jarenlang onberispelijke prestaties te leveren, met innovatieve technologieën die het leven eenvoudiger maken – functies die je wellicht niet op gewone apparaten aantreft. Neem een paar minuten de tijd om het beste uit het apparaat te halen.

Ga naar onze website voor:



Advies over gebruik, brochures, het oplossen van problemen, service- en reparatie-informatie:

www.aeg.com/support



Registreer je product voor een betere service:

www.registeraeg.com



Koop accessoires, verbruiksartikelen en originele reserveonderdelen voor je apparaat:

www.aeg.com/shop

KLANTENSERVICE EN SERVICE

Gebruik altijd originele onderdelen.

Als u contact opneemt met onze erkende servicedienst, zorg er dan voor dat u de volgende gegevens tot uw beschikking hebt: Model, PNC, serienummer.

De informatie vindt u op het typeplaatje.

Waarschuwingen en veiligheidsinformatie

Algemene informatie en tips

Milieu-informatie

Wijzigingen voorbehouden.

INHOUDSOPGAVE

1. VEILIGHEIDSINFORMATIE.....	43	3.2 Accessoires.....	50
1.1 De veiligheid van kinderen en kwetsbare personen.....	43	4. BEDIENINGSPANEEL.....	51
1.2 Algemene veiligheid.....	44	4.1 Overzicht bedieningspaneel.....	51
2. VEILIGHEIDSVOORSCHRIFTEN.....	45	4.2 Display.....	52
2.1 Installeren.....	45	5. VOORAFGAAND AAN HET EERSTE GEBRUIK.....	52
2.2 Elektrische aansluiting.....	46	5.1 Eerste reiniging	52
2.3 Gebruik.....	47	5.2 Eerste verbinding.....	53
2.4 Onderhoud en reiniging.....	48	5.3 Eerste voorverwarming.....	53
2.5 Pyrolytische reiniging.....	48	5.4 Instellen: Waterhardheid.....	53
2.6 Bereiding met stoom.....	49	6. DAGELIJKS GEBRUIK.....	54
2.7 Binnenverlichting.....	49	6.1 Instellen: Verwarmingsfuncties.....	54
2.8 Service.....	49	6.2 Instellen: Stoomverwarmingsfunctie.....	55
2.9 Verwijdering.....	49	6.3 Instellen: Kook- En Bakassistent... ..	56
3. BESCHRIJVING VAN HET PRODUCT.....	50	6.4 Verwarmingsfuncties.....	56
3.1 Algemeen overzicht.....	50		

6.5 Notities over: Warmelucht (vochtig).....	59	11.3 Hoe gebruikt u: Pyrolytische reiniging.....	69
7. KLOKFUNCTIES.....	59	11.4 Reinigingsherinnering.....	71
7.1 Omschrijving klokfuncties.....	59	11.5 Gebruik: Ontkalken.....	71
7.2 Instellen: Klokfuncties.....	60	11.6 Ontkalkmelder.....	72
8. GEBRUIK VAN DE ACCESSOIRES.....	61	11.7 Gebruik: Spoelen.....	72
8.1 Accessoires plaatsen.....	61	11.8 Gebruik: Reservoir ledigen.....	73
8.2 Voedselsensor.....	62	11.9 Verwijderen en installeren: Deur.....	73
8.3 Gebruik: Voedselsensor.....	62	11.10 Hoe te vervangen: Lamp.....	74
9. EXTRA FUNCTIES.....	64	12. PROBLEEMOPLOSSING.....	75
9.1 Hoe kan ik opslaan: Favorieten.....	64	12.1 Wat te doen als.....	76
9.2 Toetsenblokkering.....	64	12.2 Hoe te beheren: Foutcodes.....	76
9.3 Automatische uitschakeling.....	64	12.3 Service-informatie.....	77
9.4 Koelventilator.....	65	13. ENERGIEZUINIGHEID.....	77
10. AANWIJZINGEN EN TIPS.....	65	13.1 Productinformatie en productinformatieblad.....	77
10.1 Kookadviezen.....	65	13.2 Energiebesparing.....	78
10.2 Warmelucht (vochtig).....	65	14. MENUSTRUCTUUR.....	79
10.3 Warmelucht (vochtig) – aanbevolen accessoires.....	66	14.1 Menu.....	79
10.4 Kooktafels voor testinstituten.....	66	14.2 Submenu voor: Reinigen.....	79
11. ONDERHOUD EN REINIGING.....	68	14.3 Submenu voor: Opties.....	80
11.1 Opmerkingen over de reiniging.....	68	14.4 Submenu voor: Instelling.....	80
11.2 Hoe te verwijderen: Inschuifrails/.....	69	14.5 Submenu voor: Service.....	81
		15. HET IS HEEL GEMAKKELIJK!.....	81
		16. MILIEUBESCHERMING.....	82

1. ⚠ VEILIGHEIDSINFORMATIE

Lees zorgvuldig de meegeleverde instructies voor installatie en gebruik van het apparaat. De fabrikant is niet verantwoordelijk voor verwondingen of schade die voortvloeit uit de onjuiste installatie of het onjuiste gebruik. Bewaar de instructies altijd op een veilige, toegankelijke plek voor toekomstig gebruik.

1.1 De veiligheid van kinderen en kwetsbare personen

- Dit apparaat kan worden gebruikt door kinderen van 8 jaar en ouder en door mensen met een beperkt lichamelijk, zintuiglijk of verstandelijk vermogen of een gebrek aan ervaring en kennis, indien zij onder toezicht staan of

instructies hebben gekregen over het veilig gebruiken van het apparaat en indien zij de gevaren begrijpen. Kinderen jonger dan 8 jaar en personen met zware en complexe beperkingen dienen altijd uit de buurt van het apparaat te worden gehouden, tenzij ze voortdurend onder toezicht staan.

- Houd toezicht op kinderen om te voorkomen dat zij met het apparaat gaan spelen..
- Houd alle verpakking uit de buurt van kinderen en gooi het op passende wijze weg.
- **WAARSCHUWING:** Het apparaat en de toegankelijke onderdelen ervan worden heet tijdens het gebruik. Houd kinderen en huisdieren uit de buurt van het apparaat tijdens het gebruik en bij het afkoelen.
- Als het apparaat is voorzien van een kinderslot, dient dit te worden geactiveerd.
- Kinderen mogen zonder toezicht geen reinigings- en onderhoudswerkzaamheden aan het apparaat uitvoeren.

1.2 Algemene veiligheid

- Dit apparaat is uitsluitend bestemd om mee te koken.
- Dit apparaat is bedoeld voor binnenshuis huishoudelijk gebruik.
- Dit apparaat kan worden gebruikt in kantoren, hotelkamers, bed & breakfast-kamers, boerderijgasthuizen en andere soortgelijke accommodaties waar dergelijk gebruik de (gemiddelde) huishoudelijke gebruiksniveaus niet overschrijdt.
- Alleen een erkende installatietechnicus mag dit apparaat installeren en de kabel vervangen.
- Gebruik het apparaat niet voordat u het in de ingebouwde constructie installeert.
- Trek de stekker van het apparaat uit het stopcontact voordat u welke soort onderhoud dan ook gaat uitvoeren.

- Als het netsnoer beschadigd is, moet de fabrikant, een erkend servicecentrum of een gekwalificeerde persoon deze vervangen teneinde gevaarlijke situaties met elektriciteit te voorkomen.
- **WAARSCHUWING:** Zorg ervoor dat het apparaat is uitgeschakeld voordat u de lamp vervangt om elektrische schokken te voorkomen.
- **WAARSCHUWING:** Het apparaat en de toegankelijke onderdelen ervan worden heet tijdens het gebruik. Zorg ervoor dat je de verwarmingselementen of het oppervlak van de apparaatruimte niet aanraakt.
- Gebruik altijd ovenhandschoenen om accessoires of ovenschalen te verwijderen of erin te plaatsen.
- Gebruik alleen de voedselsensor (kerntemperatuursensor) die voor dit apparaat wordt aangeraden.
- Om de inschuifrailen te verwijderen trek eerst de voorkant van de inschuifrail en dan de achterkant uit de zijwanden. Plaats de inschuifrails in omgekeerde volgorde.
- Gebruik geen stoomreiniger om het apparaat schoon te maken.
- Gebruik nooit agressieve reinigingsmiddelen of scherpe metalen schrapers om de glazen deur schoon te maken. Deze kunnen krassen veroorzaken op het oppervlak, waardoor het glas zou kunnen breken.
- Haal, vóór pyrolytische reiniging, alle accessoires en overmatige afzettingen/morsingen uit de ovenruimte van het apparaat.

2. VEILIGHEIDSVOORSCHRIFTEN

2.1 Installeren

**WAARSCHUWING!**

Alleen een erkende installatietechnicus mag het apparaat installeren.

- Verwijder alle verpakkingsmaterialen.
- Installeer en gebruik geen beschadigd apparaat.
- Volg de installatie-instructies die zijn meegeleverd met het apparaat.

VEILIGHEIDSVOORSCHRIFTEN

- Pas altijd op bij verplaatsing van het apparaat, want het is zwaar. Gebruik altijd veiligheidshandschoenen en gesloten schoeisel.
- Trek het apparaat nooit aan de handgreep van zijn plaats.
- Installeer het apparaat op een veilige en geschikte plaats die aan alle installatie-eisen voldoet.
- Houd de minimumafstand naar andere apparaten en units in acht.
- Controleer, voordat je het apparaat monteert, of de ovendeur onbelemmerd open is.
- Het apparaat is uitgerust met een elektrisch koelsysteem. Het moet worden gebruikt met de elektrische voeding.
- De inbouwunit moet voldoen aan de stabiliteitsvereisten van DIN 68930.

Minimumhoogte kast (Minimumhoogte kast onder werkblad)	578 (600) mm
Kastbreedte	560 mm
Kastdiepte	550 (550) mm
Hoogte van de voorkant van het apparaat	594 mm
Hoogte van de achterkant van het apparaat	576 mm
Breedte van de voorkant van het apparaat	595 mm
Breedte van de achterkant van het apparaat	559 mm
Diepte van het apparaat	567 mm
Ingebouwde diepte van het apparaat	546 mm
Diepte met open deur	1027 mm
Minimumgrootte ventilatieopening. Opening geplaatst aan de onderkant van de achterzijde	560x20 mm
Lengte netvoedingskabel. Kabel wordt in de rechterhoek van de achterzijde geplaatst	1500 mm
Bevestigingsschroeven	4x25 mm

2.2 Elektrische aansluiting



WAARSCHUWING!

Gevaar voor brand en elektrische schokken.

- Alle elektrische aansluitingen moeten door een gediplomeerd elektromonteur worden gemaakt.
- Dit apparaat moet worden aangesloten op een geaard stopcontact.

- Zorg ervoor dat de parameters op het vermogensplaatje overeenkomen met elektrische vermogen van de netstroom.
- Gebruik altijd een juist geïnstalleerd schokbestendig stopcontact.
- Gebruik geen adapters met meerdere stekkers en verlengkabels.
- Zorg dat u de netstekker en het netsnoer niet beschadigt. Indien de voedingskabel moet worden vervangen, dan moet dit gebeuren door onze Klantenservice.
- Laat de stroomkabel niet in aanraking komen met de deur van het apparaat of de niche onder het apparaat, met name niet als deze werkt of als de deur heet is.
- De schokbescherming van delen onder stroom en geïsoleerde delen moet op zo'n manier worden bevestigd dat het niet zonder gereedschap kan worden verplaatst.
- Steek de stekker pas in het stopcontact als de installatie is voltooid. Zorg ervoor dat het netsnoer na installatie bereikbaar is.
- Als het stopcontact los zit, mag u de stekker niet in het stopcontact steken.
- Trek niet aan het netsnoer om het apparaat los te koppelen. Trek altijd aan de stekker.
- Gebruik enkel correcte isolatievoorzieningen: stroomonderbrekers, zekeringen (schroefzekeringen moeten uit de houder worden verwijderd), aardlekschakelaars en contactgevers.
- De elektrische installatie moet een isolatieapparaat bevatten waardoor het apparaat volledig van het lichtnet afgesloten kan worden. Het isolatieapparaat moet een contactopening hebben met een minimale breedte van 3 mm.
- Sluit de deur van het apparaat volledig voordat u de stekker in het stopcontact steekt.
- Dit apparaat wordt geleverd met een stekker en een netsnoer.

2.3 Gebruik



WAARSCHUWING!

Gevaar voor letsel, brandwonden, elektrische schokken of een explosie.

- De specificatie van dit apparaat niet wijzigen.
- Zorg ervoor dat de ventilatieopeningen niet geblokkeerd worden.
- Laat het apparaat tijdens de werking niet onbeheerd achter.
- Schakel het apparaat na elk gebruik uit.
- Wees voorzichtig met het openen van de deur van het apparaat wanneer het apparaat in werking is. Er kan hete lucht vrijkomen.
- Gebruik het apparaat niet met natte handen of als het contact maakt met water.
- Oefen geen druk uit op de open deur.
- Gebruik het apparaat niet als werkblad of als opslagoppervlak.
- Open de deur van het apparaat voorzichtig. Het gebruik van ingrediënten met alcohol kan een mengsel van alcohol en lucht veroorzaken.
- Laat geen vonken of open vlammen in contact met het apparaat komen wanneer u de deur opent.
- Plaats geen ontvlambare producten of artikelen die vochtig zijn met ontvlambare producten in, bij of op het apparaat.



WAARSCHUWING!

Risico op schade aan het apparaat.

- Om schade of verkleuring van het email te voorkomen:
 - plaats ovenschalen of andere voorwerpen niet rechtstreeks op de bodem van het apparaat.
 - leg geen aluminiumfolie op de bodem van de ruimte in het apparaat.

- plaats geen water direct in het hete apparaat.
- bewaar geen vochtige gerechten en voedsel in het apparaat nadat u klaar bent met koken.
- wees voorzichtig bij het verwijderen of bevestigen van accessoires.
- Verkleuring van het email of roestvrij staal is niet van invloed op de werking van het apparaat.
- Gebruik een diepe pan voor vochtige taarten. Vruchtensappen veroorzaken vlekken die permanent kunnen zijn.
- Kook altijd met de deur van het apparaat gesloten.
- Als het apparaat achter een meubelpaneel gemonteerd is (bijv. een deur), zorg er dan voor dat de deur nooit gesloten is als het apparaat in werking is. Warmte en vocht kunnen achter een gesloten meubelpaneel ophopen en schade aan het apparaat, de behuizing of de vloer veroorzaken. Sluit het meubelpaneel niet tot het apparaat compleet is afgekoeld na gebruik.

2.4 Onderhoud en reiniging



WAARSCHUWING!

Gevaar voor letsel, brand en schade aan het apparaat.

- Schakel het apparaat uit en trek de stekker uit het stopcontact voordat u onderhoudshandelingen verricht.
- Zorg ervoor dat het apparaat is afgekoeld. Er bestaat een risico dat de glasplaten kunnen breken.
- Vervang direct de glazen deurpanelen als deze beschadigd zijn. Neem contact op met een erkend servicecentrum.
- Wees voorzichtig als u de deur van het apparaat verwijdert. De deur is zwaar!
- Reinig het apparaat regelmatig om te voorkomen dat het materiaal van het oppervlak achteruitgaat.
- Maak het apparaat schoon met een vochtige zachte doek. Gebruik alleen neutrale schoonmaakmiddelen. Gebruik geen schuurmiddelen, schuursponsjes, oplosmiddelen of metalen voorwerpen.
- Volg als u een ovenspray gebruikt de aanwijzingen op de verpakking.

2.5 Pyrolytische reiniging



WAARSCHUWING!

Risico op letsel / Brand / Chemische uitstoot (dampen) in pyrolytische modus.

- Voor het uitvoeren van de pyrolytische reiniging en de eerste voorverwarming dient u het volgende uit de ovenruimte te verwijderen:
 - overtollig voedselresten, olie- of vetresten/afzettingen.
 - alle verwijderbare voorwerpen (inclusief planken, zijrails, enz., die bij het apparaat zijn geleverd), met name alle antiaanbakpotten, pannen, dienbladen, keukengerei, enz.
- Lees zorgvuldig alle instructies voor pyrolytische reiniging.
- Houd kinderen uit de buurt van het apparaat als de pyrolytische reiniging in werking is. Het apparaat wordt zeer heet en er komt hete lucht vrij uit de voorste koelopeningen.
- Pyrolytische reiniging gebeurt op hoge temperaturen waarbij dampen kunnen vrijkomen van kookresten en constructiematerialen. Om die reden adviseren wij consumenten:
 - zorg voor goede ventilatie tijdens en na de pyrolytische reiniging.
 - zorg voor goede ventilatie tijdens en na de eerste voorverwarming.

- Tijdens en na de pyrolytische reiniging mag u geen water op de ovendeur morsen of aanbrengen om beschadiging van de glasplaten te voorkomen.
- Rookgassen die vrijkomen uit alle pyrolytische ovens / kookresten zoals beschreven, zijn niet schadelijk voor mensen, inclusief kinderen of personen met medische aandoeningen.
- Houd huisdieren uit de buurt van het apparaat tijdens en na de pyrolytische reiniging en de initiële voorverwarming. Kleine huisdieren (vooral vogels en reptielen) kunnen zeer gevoelig zijn voor temperatuurveranderingen en uitgestoten dampen.
- Antiaanbaklagen in potten, pannen, bakplaten, bakgerei, enz. kunnen worden beschadigd door de hoge temperatuur van de pyrolytische reiniging van alle pyrolytische ovens. Ook kunnen ze een bron zijn voor schadelijke dampen op laag niveau.

2.6 Bereiding met stoom



WAARSCHUWING!

Gevaar voor brandwonden en schade aan het apparaat.

- Vrijgekomen stoom kan brandwonden veroorzaken:
 - Wees voorzichtig met het openen van de deur van het apparaat als de functie is geactiveerd. Er kan stoom vrijkomen.
 - De deur van het apparaat voorzichtig openen na de bereiding met stoom.

2.7 Binnenverlichting



WAARSCHUWING!

Gevaar voor elektrische schokken.

- Met betrekking tot de lamp(en) in dit product en reservelampen die afzonderlijk worden verkocht: Deze lampen zijn bedoeld om bestand te zijn tegen extreme fysieke omstandigheden in huishoudelijke apparaten, zoals temperatuur, trillingen, vochtigheid, of zijn bedoeld om informatie te geven over de operationele status van het apparaat. Ze zijn niet bedoeld voor gebruik in andere toepassingen en zijn niet geschikt voor verlichting in huishoudelijke ruimten.
- Dit product bevat een lichtbron van energie-efficiëntieklasse G.
- Gebruik alleen lampjes met dezelfde specificaties.

2.8 Service

- Neem contact op met de erkende servicedienst voor reparatie van het apparaat.
- Gebruik alleen originele reserveonderdelen.

2.9 Verwijdering



WAARSCHUWING!

Gevaar voor letsel of verstikking.

- Neem contact op met uw plaatselijke overheid voor informatie over het afvoeren van het apparaat.
- Haal de stekker uit het stopcontact.
- Snijd het netsnoer vlak bij het apparaat af en gooi het weg.
- Verwijder de deurvergrendeling om te voorkomen dat kinderen of huisdieren binnen in het apparaat vast komen te zitten.

3. BESCHRIJVING VAN HET PRODUCT

3.1 Algemeen overzicht

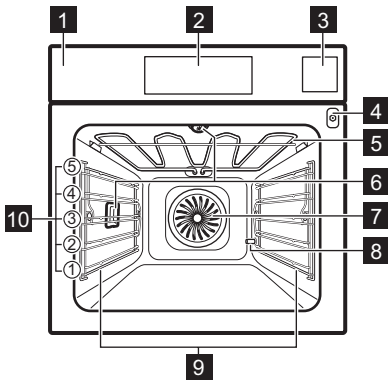

- 1 Bedieningspaneel
- 2 Display
- 3 Waterreservoir
- 4 Opening voor de voedselsensor
- 5 Verwarmingselement
- 6 Lamp
- 7 Ventilator
- 8 Uitgang ontkalkingsleiding
- 9 Inschuifrails, verwijderbaar
- 10 Inzetniveaus

3.2 Accessoires

Bakrooster

Voor kookgerei, bak- en braadvormen.

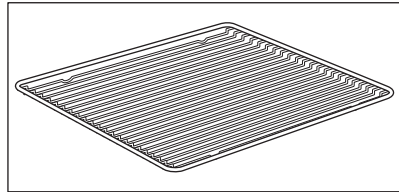

Bakplaat

Voor gebak en koekjes.

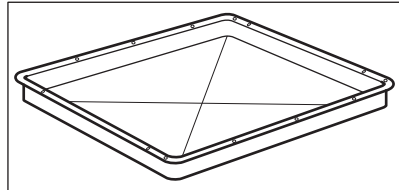

Grill-/braadpan

Om te bakken en braden of als een pan om vet in op te vangen.

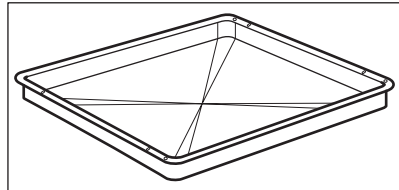

Voedselsensor

Om de temperatuur binnenin het voedsel te meten.

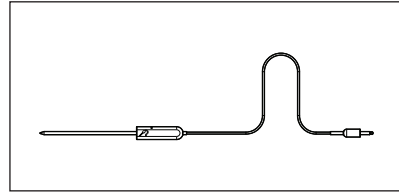

4. BEDIENINGSPANEEL

4.1 Overzicht bedieningspaneel

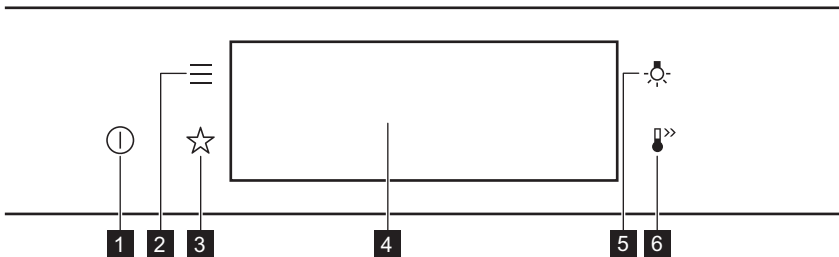

1	Aan / UIT	Houd ingedrukt om het apparaat in en uit te schakelen.
2	Menu	Vermeldt de functies van het apparaat.
3	Favorieten	Geeft een overzicht van de favoriete instellingen.
4	Display	Geeft de huidige instellingen van het apparaat weer.
5	Lampschakelaar	Om de verlichting in en uit te schakelen.
6	Snel opwarmen	Om de functie in en uit te schakelen: Snel opwarmen.

<p>Druk</p>	<p>Verplaatsen</p>	<p>Ingedrukt houden</p>
Raak het oppervlak aan met de vingertop.	Schuif de vingertop over het oppervlak.	Raak het oppervlak 3 seconden aan.

VOORAFGAAND AAN HET EERSTE GEBRUIK

4.2 Display

	<p>Display met ingestelde toetsfuncties.</p> <ul style="list-style-type: none">A. DagtijdB. BEGIN/STOPC. TemperatuurD. VerwarmingsfunctiesE. TimerF. Voedselsensor (alleen geselecteerde modellen)
--	---------------------------------------------------------------------------------------------------------------------------------------------------------------------------------------------------------------------------------------------------------------

Indicatielampjes op de display

Basisindicatielampjes: om op de display te navigeren.			
 Om de selectie/instelling te bevestigen.	 Om één niveau terug te gaan in het menu.	 Om de laatste handeling ongedaan te maken.	 Om de opties in en uit te schakelen.
Geluidsalarm functie-indicatielampjes: wanneer de ingestelde kooktijd ten einde is, klinkt het signaal.			
 De functie is ingeschakeld.	 De functie is ingeschakeld. Het koken stopt automatisch.	 Het geluidsalarm staat uit.	
Indicatielampjes timer			
 De functie instellen: Uitgestelde start.		 Om de instelling te annuleren.	

5. VOORAFGAAND AAN HET EERSTE GEBRUIK



WAARSCHUWING!

Raadpleeg de hoofdstukken Veiligheid.

5.1 Eerste reiniging



VOORAFGAAND AAN HET EERSTE GEBRUIK

Stap 1	Stap 2	Stap 3
Haal alle accessoires en verwijderbare inschuifrails uit het apparaat.	Reinig het apparaat en de accessoires uitsluitend met een microvezeldoek, warm water en een mild reinigingsmiddel.	Plaats de accessoires en de verwijderbare inschuifrails in de oven.



5.2 Eerste verbinding

Het display toont een welkomstbericht na de eerste verbinding.

Je moet het volgende instellen: Taal, Helderheid display, Toetstonen, Geluidsvolume, Waterhardheid, , Dagtijd.

5.3 Eerste voorverwarming





Warm de lege oven voor het eerste gebruik voor.

Stap 1	Haal alle accessoires en verwijderbare inschuifrails uit de oven.
Stap 2	Stel de maximale temperatuur in voor de functie:  Laat de oven één uur werken.
Stap 3	Stel de maximale temperatuur in voor de functie:  Laat de oven 15 minuten werken.

 De oven kan een vreemde geur en rook afgeven tijdens het voorverwarmen. Zorg ervoor dat de kamer goed is geventileerd.

5.4 Instellen: Waterhardheid

Als u de stekker van de oven in het stopcontact steekt, dan moet u de waterhardheid instellen. Gebruik het testpapier of neem contact op met uw waterleverancier om het waterhardheidsniveau te controleren.





			
Stap 1	Stap 2	Stap 3	Stap 4
Plaats het testpapier ongeveer 1 seconde in water. Plaats het testpapier niet onder lopend water.	Schud met het testpapier om het overschot aan water te verwijderen.	Controleer na 1 minuut de waterhardheid aan de hand van de onderstaande tabel.	Het waterhardheidsniveau instellen: Menu / Instellingen / Instelling / Waterhardheid.

DAGELIJKS GEBRUIK

 De kleuren van het testpapier blijven veranderen. Controleer de waterhardheid niet eerder dan 1 minuut na de test.

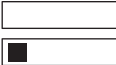
U kunt het waterhardheidsniveau wijzigen in het menu: Instellingen / Instelling / Waterhardheid.

De tabel toont het waterhardheidsbereik (dH) met het bijbehorende calciumafzettingsniveau en de waterclassificatie. Pas het waterhardheidsniveau aan volgens de tabel.

Waterhardheid		Testpapier	Kalkafzetting (mmol/l)	Kalkafzetting (mg/l)	Waterclassificatie
Niveau	dH				
1	0 - 7		0 - 1.3	0 - 50	zacht
2	8 - 14		1.4 - 2.5	51 - 100	gematigd hard
3	15 - 21		2.6 - 3.8	101 - 150	hard
4	≥ 22		≥ 3,9	≥ 151	zeer hard

Als het kraanwaterhardheidsniveau 4 is, vult u de waterlade met plat flessenwater.

6. DAGELIJKS GEBRUIK



WAARSCHUWING!



Raadpleeg de hoofdstukken Veiligheid.

6.1 Instellen: Verwarmingsfuncties

Stap 1	Zet de oven aan. Op het display verschijnt de standaard verwarmingsfunctie.
Stap 2	Druk op het symbool van de verwarmingsfunctie om het submenu te openen.
Stap 3	Selecteer de verwarmingsfunctie en druk op: OK . Het display toont: temperatuur.
Stap 4	Instellen: temperatuur. Druk op: OK .
Stap 5	Druk op: START . Voedselsensor - u kunt de sensor op elk gewenst moment voor of tijdens het koken aansluiten.

STOP - druk hierop om de verwarmingsfunctie uit te schakelen.	
Stap 6	Schakel de oven uit.

6.2 Instellen: Stoomverwarmingsfunctie

Stap 1	Zet de oven aan. Selecteer het symbool van de verwarmingsfunctie en druk erop om het submenu te openen.
Stap 2	Druk op  . Stel de stoomverwarmingsfunctie in.
Stap 3	Druk op: OK. Het display toont de temperatuurinstellingen.
Stap 4	Stel de temperatuur in.
Stap 5	Druk op: OK.
Stap 6	Druk op de afdekking van het waterreservoir om dit te openen.
Stap 7	<p>Vul de waterlade tot het maximale niveau met koud water (ongeveer 950 ml) tot het geluidssignaal klinkt of het display het bericht toont. Vul het waterreservoir niet boven de maximale capaciteit. Er is een risico op waterlekkage, overstroming en beschadiging van meubels.</p> <div style="border: 1px solid black; padding: 5px; margin-top: 10px;"> <p> WAARSCHUWING! Gebruik alleen koud kraanwater. Gebruik geen gefilterd (gedemineeraliseerd) of gedestilleerd water. Gebruik geen andere vloeistoffen. Giet geen ontvlambare of alcoholische vloeistoffen in het waterreservoir.</p> </div>
Stap 8	Druk het waterreservoir in de oorspronkelijke stand.
Stap 9	Druk op: START . Stoom verschijnt na ongeveer 2 minuten. Als de oven de ingestelde temperatuur bereikt, klinkt er een geluidssignaal.
Stap 10	Wanneer het waterreservoir zonder water komt te zitten, klinkt het signaal. Vul het waterreservoir bij.
Stap 11	Schakel de oven uit.

Stap 12	Leeg de waterlade wanneer je klaar bent met koken. Zie het hoofdstuk 'Onderhoud en reiniging', Reservoir ledigen.
Stap 13	Restwater kan condenseren in de holte. Open na het koken voorzichtig de ovendeur. Wanneer de oven koud is, droog je de ovenruimte met een zachte doek.

6.3 Instellen: Kook- En Bakassistent



Elk gerecht in dit submenu heeft een aanbevolen functie en temperatuur. U kunt de tijd en de temperatuur aanpassen.

Voor sommige gerechten kunt u ook koken met:

- Per gewicht
- Voedselsensor



Tot hoeverre een gerecht wordt gekookt:







- Rauw of Minder
- Medium
- Gaar of Meer

Stap 1	Schakel de oven in.
Stap 2	Druk op:  .
Stap 3	Druk op:  . Voer in: Kook- En Bakassistent.
Stap 4	Kies een gerecht of een voedseltype.
Stap 5	Druk op: START .



6.4 Verwarmingsfuncties

STANDAARD







Verwarmingsfunctie	Toepassing
 Grillen	Om dunne stukken voedsel te grillen en brood te roosteren.
 Circulatiegrill	Voor het braden van grote stukken vlees of gevogelte met bot op één niveau. Voor gratineren en bruinen.

Verwarmingsfunctie	Toepassing
 <p>Hetelucht</p>	Bakken op maximaal drie rekstanden tegelijkertijd en voedsel drogen. Stel de temperatuur 20 - 40 °C lager in dan voor Boven + onderwarmte.
 <p>Bevroren gerechten</p>	Om kant-en-klaar-gerechten (bijv. patat, aardappelpartjes of loempia's) krokant te maken.
 <p>Boven + onderwarmte</p>	Voor het bakken en roosteren op één ovenniveau.
 <p>Pizza-functie</p>	Voor het bakken van pizza. Voor intensieve bruining en een krokante bodem.
 <p>Onderwarmte</p>	Voor het bakken van taarten met een krokante bodem en het bewaren van voedsel.
 <p>Deeg laten rijzen</p>	Om het rijzproces van gistdeeg te versnellen. Het voorkomt dat het oppervlak van het deeg uitdroogt en houdt het deeg elastisch.

SPECIAAL



Verwarmingsfunctie	Toepassing
 <p>Inmaken</p>	Voor het inmaken van groenten (bijv. augurken).
 <p>Drogen</p>	Om in plakjes gesneden fruit, groenten en champignons te drogen.

DAGELIJKS GEBRUIK

Verwarmingsfunctie	Toepassing
 Borden warmen	Om borden voor het serveren op te warmen.
 Ontdooien	Om voedsel te ontdooien (groenten en fruit). De ontdooitijd is afhankelijk van de hoeveelheid ingevroren voedsel en de grootte daarvan.
 Gratineren	Voor gerechten zoals lasagne of aardappelgratin. Voor gratineren en bruenen.
 Lage temperatuur garen	Om malse, sappige braadstukken te bereiden.
 Warm houden	Om voedsel warm te houden.
 Warmelucht (vochtig)	Deze functie is ontworpen om tijdens de bereiding energie te besparen. Bij het gebruik van deze functie kan de temperatuur in de ruimte verschillen van de ingestelde temperatuur. De restwarmte wordt gebruikt. Het verwarmingsvermogen kan worden verminderd. Raadpleeg voor meer informatie het hoofdstuk "Dagelijks gebruik", opmerkingen op: Warmelucht (vochtig).

STOOM

Verwarmingsfunctie	Toepassing
 Regenereren	Het opwarmen van voedsel met stoom voorkomt dat het oppervlak uitdroogt. De warmte wordt behoedzaam en gelijkmatig verdeeld en geeft het voedsel de smaak en het aroma alsof het net is bereid. Deze functie kan worden gebruikt om eten direct op een bord te verwarmen. U kunt meer dan één bord tegelijkertijd opwarmen met verschillende inzetniveaus.

Verwarmingsfunctie	Toepassing
 <p>Brood bakken</p>	Gebruik deze functie voor brood en broodjes met heel goed professioneel resultaat qua kroktheid, kleur en bruine korst.
 <p>Lage vochtigheid</p>	De functie is geschikt voor vlees, gevogelte, ovengerechten en stoofschotels. Dankzij de combinatie van stoom en warmte wordt het vlees mals en sappig met een krokant korstje.

6.5 Notities over: Warmelucht (vochtig)

Deze functie wordt gebruikt om te voldoen aan de energie-efficiëntieklasse en ecodesign-vereisten (overeenkomstig EU 65/2014 en EU 66/2014). Testen in overeenstemming met: IEC/EN 60350-1

De ovendeur dient tijdens de bereiding gesloten te zijn zodat de functie niet wordt onderbroken en de oven werkt op de hoogst mogelijke energie-efficiëntie.

Bij gebruik van deze functie gaat de verlichting na 30 seconden automatisch uit.

Zie voor bereidingsinstructies het hoofdstuk 'Aanwijzingen en tips', Warmelucht (vochtig). Kijk voor algemene aanbevelingen voor energiebesparing in het hoofdstuk 'Energie-efficiëntie', Energiebesparing.

7. KLOKFUNCTIES

7.1 Omschrijving klokfuncties

Klokfunctie	Toepassing
Kooktijd	De duur van het koken instellen. Maximaal 23 uur 59 min.
Actie beëindigen	Voor het instellen wat er gebeurt als de timer stopt met tellen.
Uitgestelde start	Om het begin en/of het einde van het koken uit te stellen.
Tijd verlenging	Om de kooktijd te verlengen.
Herinnering	Om een aftelling in te stellen. Maximum is 23 uur 59 min. Deze functie heeft geen invloed op de werking van de oven.
Uptimer	Controleert hoelang de functie werkt. Uptimer - je kunt deze in- en uitschakelen.

7.2 Instellen: Klokfuncties

De klok instellen	
Stap 1	Druk op: Dagtijd.
Stap 2	Stel de tijd in. Druk op: OK.

De bereidingstijd instellen	
Stap 1	Kies de verwarmingsfunctie en stel de temperatuur in.
Stap 2	Druk op:  .
Stap 3	Stel de tijd in. Druk op: OK.

De eindoptie kiezen	
Stap 1	Kies de verwarmingsfunctie en stel de temperatuur in.
Stap 2	Druk op:  .
Stap 3	Stel de bereidingstijd in.
Stap 4	Druk op: ● ● ● .
Stap 5	Druk op: Actie beëindigen.
Stap 6	Kies je voorkeur: Actie beëindigen.
Stap 7	Druk op: OK. Herhaal de actie totdat het hoofdscherm op het display verschijnt.

Het begin van het koken uitstellen	
Stap 1	Stel de verwarmingsfunctie en de temperatuur in.
Stap 2	Druk op:  .
Stap 3	Stel de bereidingstijd in.

GEBRUIK VAN DE ACCESSOIRES

Het begin van het koken uitstellen	
Stap 4	Druk op: ● ● ● .
Stap 5	Druk op: Uitgestelde start.
Stap 6	Kies de waarde.
Stap 7	Druk op: OK. Herhaal de actie totdat het hoofdscherm op het display verschijnt.

De bereidingstijd verlengen
Wanneer 10% van de bereidingstijd overblijft en het voedsel niet klaar lijkt te zijn, kun je de bereidingstijd verlengen. Je kunt ook de verwarmingsfunctie wijzigen.
Druk op +1min om de bereidingstijd te verlengen.

De timerinstellingen wijzigen	
Stap 1	Druk op: ⌚.
Stap 2	Stel de timerwaarde in.
Stap 3	Druk op: OK.
Je kunt de ingestelde tijd tijdens het koken op elk gewenst moment wijzigen.	

8. GEBRUIK VAN DE ACCESSOIRES



WAARSCHUWING!

Raadpleeg de hoofdstukken Veiligheid.

8.1 Accessoires plaatsen

Een kleine inkeping bovenaan verhoogt de veiligheid. De inkepingen zijn ook anti-kantelmecanismen. De hoge rand rond het rooster voorkomt dat het kookgerei van het rooster afglijdt.

GEBRUIK VAN DE ACCESSOIRES

Bakrooster:

Plaats het rooster tussen de geleidestangen van de roostersteun.

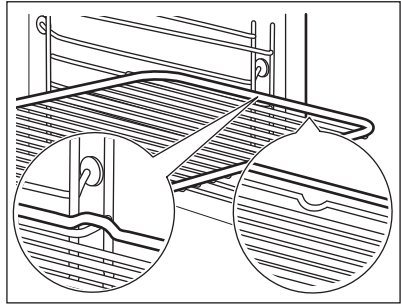

Bakplaat / Diepe schaal:

Schuif de plaat tussen de geleidestangen van de inschuifrail.

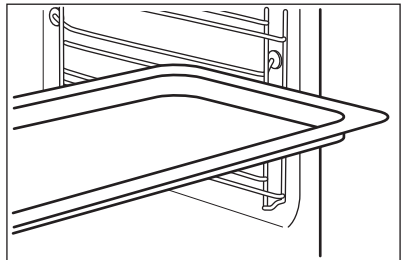

8.2 Voedselsensor

Voedselsensor- meet de temperatuur binnenin het voedsel. Je kunt het bij elke verwarmingsfunctie gebruiken.

Er moeten twee temperaturen worden ingesteld:

°C

De oventemperatuur: (minimaal 120 °C).



De kerntemperatuur.

Voor de beste kookresultaten:

Ingrediënten moeten op kamertemperatuur zijn.

Niet gebruiken voor vloeibare gerechten.

Tijdens het koken moet het in de schaal blijven.



De oven berekent een geschatte bereidingseindtijd. Dit hangt af van de voedselkwaliteit, de ingestelde ovenfunctie en de temperatuur.

8.3 Gebruik: Voedselsensor

Stap 1

Schakel de oven in.

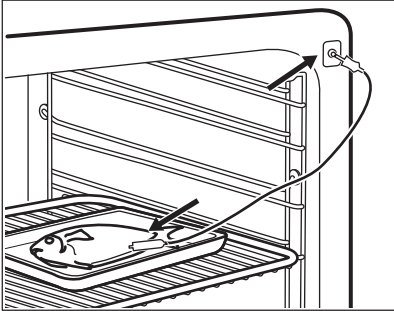
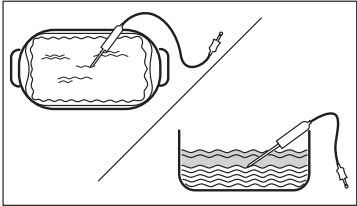
GEBRUIK VAN DE ACCESSOIRES

Stap 2	Selecteer de verwarmfunctie en, indien nodig, de oventemperatuur.
Stap 3	Invoegen: Voedselsensor.
Vlees, gevogelte en vis	Stoofschotel
Breng het uiteinde van Voedselsensor in het midden van het vlees, de vis, in het dikste deel indien mogelijk. Zorg ervoor dat ten minste 3/4 van Voedselsensor binnen in het gerecht zit.	Breng het uiteinde van Voedselsensor precies in het midden van de braadpan. Voedselsensor moet stevig op zijn plaats blijven tijdens het bakproces. Gebruik een solide ingrediënt om dit voor elkaar te krijgen. Gebruik de rand van de ovenschaal voor het ondersteunen van het silicone handvat van de Voedselsensor. Het uiteinde van Voedselsensor mag de bodem van een bakplaat niet aanraken.
	
Stap 4	Stekker Voedselsensor steek in de aansluiting aan de voorkant van de oven. Het display toont de huidige temperatuur van: Voedselsensor.
Stap 5	 - druk om de kerntemperatuur van de sensor in te stellen.
Stap 6	<ul style="list-style-type: none"> ● ● ● - druk om de voorkeursoptie in te stellen: • Geluidsalarm - wanneer het voedsel de kerntemperatuur bereikt, klinkt het signaal. • Geluidsalarm en stop met koken - wanneer het voedsel de kerntemperatuur bereikt, klinkt het signaal en stopt de oven.
Stap 7	Selecteer de optie en druk herhaaldelijk op: OK om naar het hoofdscherm te gaan.
Stap 8	Druk op: START . Wanneer het voedsel de ingestelde temperatuur bereikt, klinkt het signaal. U kunt ervoor kiezen om te stoppen of door te gaan met koken, om er zeker van te zijn dat het voedsel goed gaar is.



EXTRA FUNCTIES

Stap 9	Verwijderen Voedselsensor haal de stekker uit het stopcontact en neem het gerecht uit de oven. <div style="border: 1px solid black; padding: 5px; margin-top: 10px;"> WAARSCHUWING! Er bestaat gevaar voor brandwonden omdat Voedselsensor heet wordt. Wees voorzichtig wanneer u de stekker eruit haalt en de voedingsensor uit het gerecht haalt.</div>
---------------	----------------------------------------------------------------------------------------------------------------------------------------------------------------------------------------------------------------------------------------------------------------------------------------------------------------------------------------------------------------------------------------------------------------------------------------------------------

9. EXTRA FUNCTIES



9.1 Hoe kan ik opslaan: Favorieten

U kunt uw favoriete instellingen opslaan, zoals de verwarmingsfunctie, de bereidingstijd, de temperatuur of de reinigingsfunctie. U kunt 3 favoriete instellingen opslaan.

Stap 1	Het apparaat inschakelen.
Stap 2	Selecteer de gewenste instelling.
Stap 3	Druk op:  . Selecteer: Favorieten.
Stap 4	Selecteer: Huidige instellingen opslaan.
Stap 5	Druk op + om de instelling toe te voegen aan de lijst met: Favorieten. Druk op OK .
 - druk hierop om de instelling te resetten.  - druk hierop om de instelling te annuleren.	



9.2 Toetsenblokkering

Deze functie voorkomt dat de verwarmingsfunctie per ongeluk wordt gewijzigd.

Stap 1	Het apparaat inschakelen.
Stap 2	Stel een verwarmingsfunctie in.
Stap 3	 ,  - druk hier tegelijkertijd op om de functie in te schakelen.
Herhaal stap 3 om de functie uit te schakelen.	

9.3 Automatische uitschakeling

Om veiligheidsredenen schakelt de oven na bepaalde tijd uit als er een ovenfunctie in werking is en u geen instellingen wijzigt.

 (°C)	 (u)
30 - 115	12.5
120 - 195	8.5
200 - 245	5.5
250 - maximaal	3

De automatische uitschakeling werkt niet met de functies: Binnenverlichting, Voedselsensor, Eindtijd, Lage temperatuur garen.

9.4 Koelventilator

Als het apparaat in werking is, wordt de koelventilator automatisch ingeschakeld om de oppervlakken van het apparaat koel te houden. Als je het apparaat uitschakelt, kan de koelventilator blijven werken totdat het apparaat is afgekoeld.

10. AANWIJZINGEN EN TIPS

10.1 Kookadviezen







De temperatuur en kooktijden in de tabellen zijn slechts als richtlijn bedoeld. Ze zijn afhankelijk van het recept, de kwaliteit en de kwantiteit van de gebruikte ingrediënten. Je apparaat kan anders bakken of roosteren dan het apparaat dat je tot nu toe gebruikt hebt. De onderstaande hints tonen aanbevolen instellingen voor temperatuur, kooktijd en rekstand voor specifieke soorten voedsel.

Als u voor een speciaal recept de instelling niet kunt vinden, zoek dan naar een soortgelijk recept. Voor meer kookaanbevelingen kunt u de kooktabellen op onze website raadplegen. Om de Kookhints te vinden, controleer het PNC-nummer op het classificatieplaatje op de voorzijde van het frame van de binnenkant van het apparaat.

10.2 Warmelucht (vochtig)



Volg voor de beste resultaten de volgende aanwijzingen op die hieronder in de tabel staan.

AANWIJZINGEN EN TIPS

		 (°C)		 (min)
Zoete broodjes, 16 stuks	bakplaat of lekschaal	180	2	25 - 35
Biscuitrol	bakplaat of lekschaal	180	2	15 - 25
Hele vis, 0,2 kg	bakplaat of lekschaal	180	3	15 - 25
Koekjes, 16 stuks	bakplaat of lekschaal	180	2	20 - 30
Bitterkoekjes, 24 stuks	bakplaat of lekschaal	160	2	25 - 35
Muffins, 12 stuks	bakplaat of lekschaal	180	2	20 - 30
Hartig gebak, 20 stuks	bakplaat of lekschaal	180	2	20 - 30
Zandkoekjes, 20 stuks	bakplaat of lekschaal	140	2	15 - 25
Taartjes, 8 stuks	bakplaat of lekschaal	180	2	15 - 25

10.3 Warmelucht (vochtig) – aanbevolen accessoires

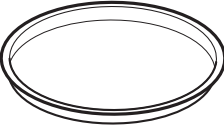
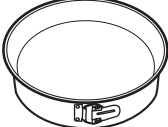
Gebruik de donkere en niet-reflecterende bakjes en schalen. Ze nemen de warmte beter op dan licht en reflecterend servies.





			
Pizza pan	Ovenschaal	Ovenvormpjes	Blik voor flanbodem
Donker, niet-reflecterend Diameter van 28 cm	Donker, niet-reflecterend Diameter van 26 cm	Keramik 8 cm diameter, 5 cm hoog	Donker, niet-reflecterend Diameter van 28 cm

10.4 Kooktafels voor testinstituten

Informatie voor testinstituten





Testen in overeenstemming met: EN 60350, IEC 60350.

Bakken op één niveau - bakken in bakblikken





		 °C	 min	
Zachte cake zonder vet	Hetelucht	160	45 - 60	2
Zachte cake zonder vet	Boven + onderwarmte	160	45 - 60	2
Appeltaart, 2 blikken Ø20 cm	Hetelucht	160	55 - 65	2
Appeltaart, 2 blikken Ø20 cm	Boven + onderwarmte	180	55 - 65	1
Zandtaartdeeg	Hetelucht	140	25 - 35	2
Zandtaartdeeg	Boven + onderwarmte	140	25 - 35	2

Bakken op één niveau - koekjes





Gebruik de derde rekstand.

		 °C	 min
Kleine cakes, 20 stuks per bakplaat, verwarm de lege oven voor	Hetelucht	150	20 - 30
Kleine cakes, 20 stuks per bakplaat, verwarm de lege oven voor	Boven + onderwarmte	170	20 - 30

Bakken op meerdere niveaus - koekjes

		 °C	 min	
Zandtaartdeeg	Hetelucht	140	25 - 45	2 / 4





ONDERHOUD EN REINIGING

		 °C	 min	
Kleine cakes, 20 stuks per bakplaat, verwarm de lege oven voor	Hetelucht	150	25 - 35	1 / 4
Zachte cake zonder vet	Hetelucht	160	45 - 55	2 / 4
Appeltaart, 1 blik per rooster (Ø 20 cm)	Hetelucht	160	55 - 65	2 / 4

Grillen

Verwarm de lege oven 5 minuten voor.

Grill met de maximale temperatuurinstelling.

		 min	
Toast	Grillen	1 - 2	5
Biefstuk, halverwege de bereidingstijd omdraaien	Grillen	24 - 30	4

11. ONDERHOUD EN REINIGING





WAARSCHUWING!

Raadpleeg de hoofdstukken Veiligheid.

11.1 Opmerkingen over de reiniging

 Reinigingsmiddelen	Reinig de voorkant van het apparaat uitsluitend met een microvezeldoek met warm water en een mild reinigingsmiddel.
	Gebruik een reinigungsoplossing om metalen oppervlakken te reinigen.
	Reinig vlekken met een mild reinigungsmiddel.

 <p>Dagelijks gebruik</p>	Reinig de uitsparing telkens na gebruik. Vetophoping of andere resten kunnen brand veroorzaken.
	Bewaar het voedsel niet langer dan 20 minuten in het apparaat. Droog de ruimte na elk gebruik uitsluitend met een microvezeldoek.

 <p>Accessoires</p>	Reinig alle accessoires na elk gebruik en laat ze drogen. Gebruik alleen een zachte doek met warm water en een mild reinigingsmiddel. De accessoires niet in een afwasmachine reinigen.
	Reinig de antiaanbakaccessoires niet met agressieve reinigingsmiddelen of scherpe voorwerpen.

11.2 Hoe te verwijderen: Inschuifrails/

Verwijder de inschuifrails om de oven te reinigen.

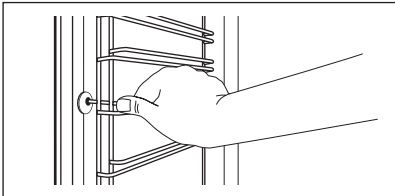
Stap 1	Schakel de oven uit en wacht totdat deze is afgekoeld.	
Stap 2	Trek de inschuifrails voorzichtig naar boven toe uit de voorste ophanging.	
Stap 3	Trek de voorkant van de inschuifrails weg van de zijwand.	
Stap 4	Trek de inschuifrails uit de achterste ophanging.	
Plaats de inschuifrails in omgekeerde volgorde.		

11.3 Hoe gebruikt u: Pyrolytische reiniging

Maak de oven schoon met Pyrolytische reiniging.



WAARSCHUWING!

Er bestaat gevaar voor brandwonden.



LET OP!

Als er andere apparaten in dezelfde kast zijn geïnstalleerd, gebruik deze dan niet tijdens deze functie. Dit kan de oven beschadigen.

ONDERHOUD EN REINIGING

Vóór de Pyrolytische reiniging:

Schakel de oven uit en wacht totdat deze is afgekoeld.	Verwijder alle accessoires uit de oven.	Reinig de onderkant van de oven en de glazen deur aan de binnenkant met warm water, een zachte doek en een mild reinigingsmiddel.
--------------------------------------------------------	-----------------------------------------	-----------------------------------------------------------------------------------------------------------------------------------

Vul de watertank niet tijdens het reinigen. Dat herstart de reinigingscyclus.

Stap 1	Schakel de oven in.
Stap 2	Druk op:  / Reinigen.
Stap 3	Zet de bakplaat op de eerste stand om het water uit het waterreservoir op te vangen. OK - druk hierop om het ledigen van het waterreservoir te starten.
Stap 4	Verwijder de bakplaat en verwijderbare inschuifrails na het ledigen van het reservoir. Veeg de ovenruimte en de glazen deur aan de binnenkant af met een zachte doek. Druk op: OK.
Stap 5	Selecteer de reinigingsmodus.

Optie	Reinigingsmodus	Duur
Pyrolytische reiniging, kort	Licht reinigen	1 h
Pyrolytische reiniging, normaal	Normaal reinigen	1 h 30 min
Pyrolytische reiniging, intensief	Grondig reinigen	3 h

 Wanneer het reinigen begint, is de lamp uit en werkt de koelventilator op een hogere snelheid.
STOP - druk hierop om het reinigen te stoppen voordat het is voltooid.
Gebruik de oven niet totdat het deurvergrendelingsymbool van het display verdwijnt.

Na afloop van het reinigen:

Schakel de oven uit en wacht totdat deze is afgekoeld.	Maak de ruimte schoon met een zachte doek.	Verwijder het residu van de bodem van de ruimte.
--------------------------------------------------------	--------------------------------------------	--------------------------------------------------

11.4 Reinigingsherinnering

Wanneer de herinnering verschijnt, wordt reiniging aanbevolen.
Gebruik de functie: Pyrolytische reiniging.

11.5 Gebruik: Ontkalken

Voordat u begint:		
Schakel de oven uit en wacht tot deze is afgekoeld.	Verwijder alle accessoires.	Controleer of het waterreservoir leeg is.

Duur van het eerste deel: ongeveer 100 min	
Stap 1	Plaats de braadpan op de eerste rekstand.
Stap 2	Giet 250 ml antikalkmiddel in het waterreservoir.
Stap 3	Vul het resterende gedeelte van het waterreservoir tot het maximumniveau met water tot het geluidssignaal klinkt of het display het bericht toont.
Stap 4	Selecteer: Menu / Reinigen.
Stap 5	Schakel de functie in en volg de instructies op het display. Het eerste deel van het ontkalken begint.
Stap 6	Nadat het eerste deel voorbij is, maakt u de braadpan leeg en plaatst u deze terug op de eerste rekstand.
Duur van het tweede deel: ongeveer 35 min	
Stap 7	Vul het resterende gedeelte van het waterreservoir tot het maximumniveau met water tot het geluidssignaal klinkt of het display het bericht toont.
Stap 8	Wanneer de functie is afgelopen, verwijdert u de braadpan.
 Wanneer deze functie werkt, is de lamp uit.	

Wanneer het ontkalken eindigt:		
Schakel de oven uit.	Wanneer de oven koud is, droogt u de ovenruimte met een zachte doek.	Laat de ovendeur open en wacht tot de ovenruimte droog is.
 Als er na het ontkalken nog wat kalksteenresten in de oven achterblijven, wordt op het display gevraagd om de procedure te herhalen.		

11.6 Ontkalkmelder

Er zijn twee melders die u de instructie geven om de oven te ontkalken. U kunt de ontkalkmelder niet uitschakelen.

Type	Omschrijving
Zachte herinnering	Raadt u aan om de oven te ontkalken.
Harde herinnering	Verplicht u om de oven te ontkalken. Als u de oven niet ontkalkt wanneer de harde herinnering is ingeschakeld, zijn de stoomfuncties uitgeschakeld.

11.7 Gebruik: Spoelen

Voordat u begint:	
Schakel de oven uit en wacht tot deze is afgekoeld.	Verwijder alle accessoires.

Stap 1	Plaats de braadpan op de eerste rekstand.
Stap 2	Vul het waterreservoir tot het maximumniveau met water tot het geluidssignaal klinkt of het display het bericht toont.
Stap 3	Selecteer: Menu / Reinigen / Spoelen. Duur: ongeveer 30 min
Stap 4	Schakel de functie in en volg de instructies op het display.
Stap 5	Wanneer de functie is afgelopen, verwijdert u de braadpan.

 Wanneer deze functie werkt, is de lamp uit.

11.8 Gebruik: Reservoir ledigen

Gebruik het met de stoomverwarmingsfunctie om het resterende water uit het waterreservoir te verwijderen.

Voordat u begint:	
Schakel de oven uit en wacht tot deze is afgekoeld.	Verwijder alle accessoires.

Stap 1	Plaats de braadpan op de eerste rekstand.
Stap 2	Selecteer: Menu / Reinigen / Reservoir ledigen. Duur: 6 min
Stap 3	Schakel de functie in en volg de instructies op het display.
Stap 4	Wanneer de functie is afgelopen, verwijdert u de braadpan.

 Wanneer deze functie werkt, is de lamp uit.

11.9 Verwijderen en installeren: Deur

U kunt de deur en de binnenste glasplaten verwijderen om ze te reinigen. U Het aantal glasplaten verschilt per model.



WAARSCHUWING!
De deur is zwaar.

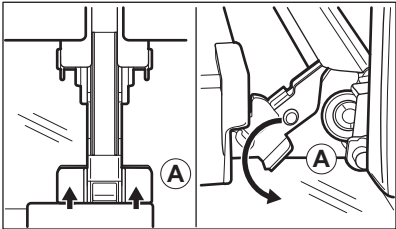

LET OPI!
Behandel het glas voorzichtig, vooral rond de randen van het voorpaneel. Het glas kan breken.

Stap 1	Open de deur volledig.	
Stap 2	Hef en druk de klemhendels (A) op de twee deurscharnieren.	
Stap 3	Sluit de ovendeur in de eerste openingsstand (in een hoek van ongeveer 70°). Houd de deur aan beide kanten vast en trek deze onder een opwaartse hoek weg van de oven. Plaats de ovendeur met de buitenkant omlaag op een zachte doek op een stabiele ondergrond.	

ONDERHOUD EN REINIGING

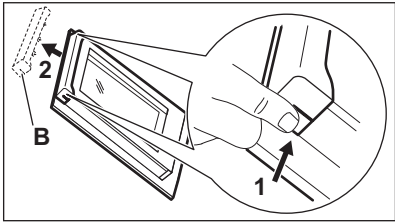
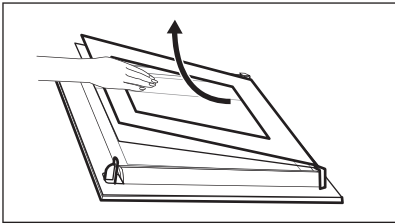
Stap 4	Pak de deurafdekking (B) aan de bovenkant van de deur aan beide kanten vast en druk deze naar binnen om de klemsluiting te ontgrendelen.	
Stap 5	Trek de deurlijst naar voren om hem te verwijderen.	
Stap 6	Houd de glasplaten aan hun bovenkant vast en trek deze een voor een omhoog uit de geleider.	
Stap 7	Reinig de glasplaat met een sopje. Droog de glasplaat voorzichtig af. Reinig de glasplaten niet in de vaatwasser.	
Stap 8	Voer na het reinigen de bovenstaande stappen in de omgekeerde volgorde uit.	
Stap 9	Plaats de kleinste glasplaat eerst, daarna de grotere glasplaat en de deur.	

11.10 Hoe te vervangen: Lamp



WAARSCHUWING!

Gevaar voor elektrische schokken.
Het lampje kan heet zijn.

Voordat u de lamp vervangt:		
Stap 1	Stap 2	Stap 3
Schakel de oven uit. Wacht tot de oven afgekoeld is.	Trek de oven uit het stopcontact.	Plaats een doek op de bodem van de holte.

Bovenlamp

Stap 1	Draai de glazen afdekking om die te verwijderen.	
Stap 2	Verwijder de metalen ring en reinig het glazen deksel.	
Stap 3	Vervang de lamp door een geschikte 300 °C hittebestendige lamp.	
Stap 4	Bevestig de metalen ring aan de glazen afdekking en installeer deze.	

Zijlamp

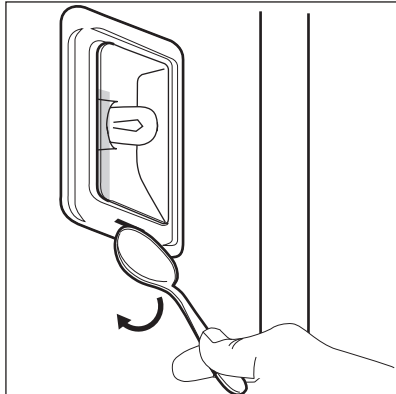
Stap 1	Verwijder de linker drager van het rek om toegang te krijgen tot de lamp.	
Stap 2	Gebruik een smal, stomp voorwerp (bijv. een theelepel) om het glazen deksel te verwijderen.	
Stap 3	Reinig de glasafdekking.	
Stap 4	Vervang de lamp door een geschikte 300 °C hittebestendige lamp.	
Stap 5	Installeer het glazen deksel.	
Stap 6	Installeer de linker drager van het rek.	



12. PROBLEEMOPLOSSING





WAARSCHUWING!

Raadpleeg de hoofdstukken Veiligheid.

12.1 Wat te doen als...



 Het apparaat gaat niet aan of warmt niet op	
 Mogelijke oorzaak	 Oplossing
Het apparaat is niet aangesloten op een stop-contact of niet goed geïnstalleerd.	Controleer of het apparaat goed is aangesloten op de elektriciteitsvoorziening.
De klok is niet ingesteld.	Stel de klok in, zie voor meer informatie Klok-functies hoofdstuk, Instellen: Klokfuncties.
De deur is niet goed gesloten.	Sluit de deur volledig.
De zekering is doorgeslagen.	Ga na of de zekering de oorzaak van het probleem is. Als het probleem zich opnieuw voordoet, neem dan contact op met een gekwalificeerde elektricien.
Het apparaat Kinderslot is aan.	Raadpleeg het hoofdstuk 'Menu', Submenu voor: Opties.

 Onderdelen	
 Omschrijving	 Oplossing
De lamp is opgebrand.	Vervang de lamp, raadpleeg voor meer informatie het hoofdstuk 'Onderhoud en reiniging', Hoe te vervangen: Lamp.

Een stroomonderbreking zal de reiniging altijd stoppen. Herhaal de reiniging als deze wordt onderbroken door stroomuitval.

12.2 Hoe te beheren: Foutcodes

Wanneer de softwarefout optreedt, geeft het display een foutmelding weer. In deze sectie vindt u de lijst met problemen die u zelf kunt oplossen.

 Code en omschrijving	 Oplossing
C2 - de Voedselsensor bevindt zich in de ovenruimte van het apparaat tijdens Pyrolytische reiniging.	Neem de Voedselsensor.
C3 eruit - de deur wordt niet volledig gesloten tijdens Pyrolytische reiniging.	Sluit de deur.
F111 - Voedselsensor wordt niet correct in het stopcontact gestoken.	Volledig aansluiten Voedselsensor in het stopcontact.
F240, F439 - de aanraakvelden op het display werken niet goed.	Reinig het oppervlak van het display. Zorg ervoor dat er geen vuil op de aanraakvelden zit.
F908 - het apparaatsysteem kan geen verbinding maken met het bedieningspaneel.	Schakel het apparaat uit en weer in.

12.3 Service-informatie

Als je niet zelf het probleem kunt verhelpen, neem dan contact op met je verkoper of een erkende serviceafdeling.

De contactgegevens van de servicedienst staan op het typeplaatje. Het typeplaatje bevindt zich op het voorframe van de apparaatruimte. Verwijder het typeplaatje niet uit de apparaatruimte.

Wij raden je aan om de gegevens hier te noteren:	
Model (MOD.)
Productnummer (PNC)
Serienummer (S.N.)

13. ENERGIEZUINIGHEID

13.1 Productinformatie en productinformatieblad

Naam leverancier	AEG
Modelnummer	BSE77280M 944188685 BSE77228BM 944188655 BSK772280M 944188643 BSS772280B 944188644

ENERGIEZUINIGHEID

Energie-efficiëntie-index	61,2	
Energie-efficiëntieklasse	A++	
Energieverbruik met een standaard belading, conventionele modus	1,09 kWh/cyclus	
Energieverbruik met een standaard belasting, heteluchtmodus	0,52 kWh/cyclus	
Aantal holtes	1	
Warmtebron	Elektriciteit	
Volume	71 l	
Soort oven	Inbouwoven	
Massa	BSE772280M	36.0 kg
	BSE77228BM	36.0 kg
	BSK772280M	36.0 kg
	BSS772280B	36.0 kg

IEC/EN 60350-1 - Huishoudelijke elektrische kooktoestellen - Deel 1: Fornuizen, ovens, stoomovens en grills - Methoden voor het meten van prestaties.

13.2 Energiebesparing



Dit apparaat heeft functies die u helpen energie te besparen tijdens het dagelijks koken.

Zorg ervoor dat de deur van het apparaat gesloten is als het apparaat in werking is. Open de deur van het apparaat niet te vaak tijdens het koken. Houd het deurrubber schoon en zorg ervoor dat het goed op zijn plaats vastzit.

Gebruik metalen kookgerei om meer energie te besparen.

Verwarm het apparaat niet voor alvorens te koken als dat niet hoeft.

Houd onderbrekingen tussen het bakken zo kort mogelijk als je een aantal gerechten tegelijkertijd bereidt.

Koken met hete lucht

Gebruik indien mogelijk de bereidingsfuncties met hete lucht om energie te besparen.

Restwarmte

Als een programma met Duur wordt geactiveerd en de bereidingstijd langer is dan 30 minuten, worden de verwarmingselementen bij sommige functies van het apparaat automatisch eerder uitgeschakeld.

De ventilator en lamp blijven werken. Wanneer je de oven uitschakelt, geeft het display de restwarmte aan. U kunt die warmte gebruiken om het eten warm te houden. Wanneer de kookduur langer is dan 30 minuten, verlaag dan de oventemperatuur tot minimaal 3-10 minuten voor het einde van het koken. De restwarmte binnen in het apparaat zal blijven koken.

Je kunt de restwarmte gebruiken om andere maaltijden op te warmen.

Eten warm houden

Kies de laagst mogelijke temperatuurinstelling om de restwarmte te gebruiken en een maaltijd warm te houden. Het indicatielampje van de restwarmte of temperatuur verschijnt op het display.

Koken met de verlichting uitgeschakeld

Schakel de verlichting tijdens het koken uit. Doe het aan als je het nodig hebt.

Warmelucht (vochtig)

Functie is ontworpen om tijdens de bereiding energie te besparen.

Als je deze functie gebruikt, gaat de verlichting na 30 sec. automatisch uit. Je kunt de verlichting weer inschakelen, maar deze handeling vermindert de verwachte energiebesparingen.

14. MENUSTRUCTUUR

14.1 Menu

Menu-item		Toepassing
Kook- En Bakassistent		Toont overzicht van de automatische programma's.
Reinigen		Toont overzicht van de schoonmaakprogramma's.
Favorieten		Geeft een overzicht van de favoriete instellingen.
Opties		Om de apparaatconfiguratie in te stellen.
Instellingen	Instelling	Om de apparaatconfiguratie in te stellen.
	Service	Toont de softwareversie en -configuratie.

14.2 Submenu voor: Reinigen

Submenu	Toepassing
Reservoir ledigen	Procedure voor het verwijderen van het restwater van de waterlade na gebruik van de stoomfuncties.
Pyrolytische reiniging, kort	Duur: 1 h.

Submenu	Toepassing
Pyrolytische reiniging, normaal	Duur: 1 h 30 min.
Pyrolytische reiniging, intensief	Duur: 3 h.
Ontkalken	Procedure om kalkresten te verwijderen van de stoomgenerator.
Spoelen	Procedure voor het spoelen en reinigen van de stoomgenerator na frequent gebruik van de stoomfuncties.

14.3 Submenu voor: Opties

Submenu	Toepassing
Binnenverlichting	Schakelt de lamp in en uit.
Kinderslot	Vorkomt dat het apparaat per ongeluk wordt geactiveerd. Als de optie is ingeschakeld, verschijnt de tekst Kinderslot op het display wanneer u het apparaat inschakelt. Om het apparaat in te kunnen schakelen de codeletters in alfabetische volgorde selecteren. Als de optie is ingeschakeld en het apparaat is uitgeschakeld, is de deur van het apparaat vergrendeld. Toegang tot de timer, de afstandbediening en het lampje zijn beschikbaar met de optie ingeschakeld.
Snel opwarmen	Verkort de opwarmtijd. Alleen beschikbaar voor sommige functies van het apparaat.
Tijdisindicatie	Schakelt de klok in en uit.
Digitale klokstijl	Wijzigt de indeling van de weergegeven tijdsaanduiding.

14.4 Submenu voor: Instelling

Submenu	Beschrijving
Taal	Stelt de taal van het apparaat in.
Helderheid display	Stelt de helderheid van de display in.

HET IS HEEL GEMAKKELIJK!

Submenu	Beschrijving
Toetstonen	Schakelt het geluid van de aanraakvelden in en uit. Het is niet mogelijk om de toon te dempen voor: ①.
Geluidsvolume	Stelt het volume van de belangrijkste geluiden en signalen in.
Waterhardheid	Stelt de waterhardheid in.
Dagtijd	Stelt de huidige tijd en datum in.

14.5 Submenu voor: Service

Submenu	Beschrijving
Demofunctie	Activerings-/deactiveringscode: 2468
Softwareversie	Informatie over softwareversie.
Terug naar fabrieksinstellingen	Herstelt fabrieksinstellingen.

15. HET IS HEEL GEMAKKELIJK!

Voorafgaand aan het eerste gebruik moet u het volgende instellen:

Taal	Helderheid display	Toetstonen	Geluidsvolume	Waterhardheid	Dagtijd
------	--------------------	------------	---------------	---------------	---------

Het apparaat beginnen te gebruiken

Snel starten	Schakel het apparaat in en begin de bereiding met de standaardtemperatuur en -tijd van de functie.	Stap 1	Stap 2	Stap 3
		Ingedrukt houden: ①.	 ... - selecteer de gewenste functie.	Druk op: START .

HET IS HEEL GEMAKKELIJK!

Het apparaat beginnen te gebruiken



Snel uit	Schakel het apparaat op elk gewenst moment uit, vanuit elk scherm of bij elk bericht.	① - ingedrukt houden tot het apparaat uitschakelt.
-----------------	---------------------------------------------------------------------------------------	----------------------------------------------------

Begin met koken

Stap 1	Stap 2	Stap 3	Stap 4	Stap 5
① - indrukken om het apparaat in te schakelen.	 ... - selecteer de verwarmingsfunctie.	°C Instellen: temperatuur.	OK - druk hierop om te bevestigen.	START - druk hierop om te beginnen met koken.

Leer snel koken



Gebruik de automatische programma's om snel een gerecht te koken met de standaardinstellingen:

Kook- En Bakassistent	Stap 1	Stap 2	Stap 3	Stap 4
	Druk op: ①.	Druk op: 	Druk op:  Kook- En Bakassistent.	Kies het gerecht.

Gebruik snelle functies om de kooktijd in te stellen

10% Finish assist Gebruik 10% Finish assist om extra tijd toe te voegen wanneer 10% van de bereidingstijd overblijft.	Druk op +1min om de bereidingstijd te verlengen.
---------------------------------------------------------------------------------------------------------------------------------	---------------------------------------------------------

16. MILIEUBESCHERMING

Recycleer de materialen met het symbool . Gooi de verpakking in een geschikte afvalcontainer om het te recyclen. Bescherm het milieu en de volksgezondheid en recycleer op een correcte manier het afval van elektrische en elektronische apparaten. Gooi apparaten gemarkeerd met het symbool  niet weg met het huishoudelijk afval. Breng het product naar het milieustation bij u in de buurt of neem contact op met de gemeente.

FOR PERFECT RESULTS

Thank you for choosing this AEG product. We have created it to give you impeccable performance for many years, with innovative technologies that help make life simpler – features you might not find on ordinary appliances. Please spend a few minutes reading to get the very best from it.

Visit our website to:



Get usage advice, brochures, trouble shooter, service and repair information:
www.aeg.com/support



Register your product for better service:
www.registeraeg.com



Buy Accessories, Consumables and Original spare parts for your appliance:
www.aeg.com/shop

CUSTOMER CARE AND SERVICE

Always use original spare parts.

When contacting our Authorised Service Centre, ensure that you have the following data available: Model, PNC, Serial Number.

The information can be found on the rating plate.

Warning / Caution-Safety information

General information and tips

Environmental information

Subject to change without notice.

CONTENTS

1. SAFETY INFORMATION.....	84	3.2 Accessories.....	91
1.1 Children and vulnerable people safety.....	84	4. CONTROL PANEL.....	91
1.2 General Safety.....	85	4.1 Control panel overview.....	91
2. SAFETY INSTRUCTIONS.....	86	4.2 Display.....	92
2.1 Installation.....	86	5. BEFORE FIRST USE.....	93
2.2 Electrical connection.....	87	5.1 Initial Cleaning	93
2.3 Use.....	88	5.2 First connection.....	93
2.4 Care and cleaning.....	88	5.3 Initial preheating.....	93
2.5 Pyrolytic cleaning.....	89	5.4 How to set: Water hardness.....	94
2.6 Steam Cooking.....	89	6. DAILY USE.....	95
2.7 Internal lighting.....	89	6.1 How to set: Heating functions.....	95
2.8 Service.....	90	6.2 How to set: Steam heating function.....	95
2.9 Disposal.....	90	6.3 How to set: Assisted Cooking.....	96
3. PRODUCT DESCRIPTION.....	90	6.4 Heating functions.....	97
3.1 General overview.....	90	6.5 Notes on: Moist Fan Baking.....	99

SAFETY INFORMATION

7. CLOCK FUNCTIONS.....	99	11.5 How to use: Descaling.....	111
7.1 Clock functions description.....	99	11.6 Descaling reminder.....	112
7.2 How to set: Clock functions.....	100	11.7 How to use: Rinsing.....	112
8. USING THE ACCESSORIES.....	101	11.8 How to use: Tank emptying.....	112
8.1 Inserting accessories.....	101	11.9 How to remove and install: Door	113
8.2 Food Sensor.....	102	11.10 How to replace: Lamp.....	114
8.3 How to use: Food Sensor.....	102	12. TROUBLESHOOTING.....	115
9. ADDITIONAL FUNCTIONS.....	104	12.1 What to do if.....	115
9.1 How to save: Favourites.....	104	12.2 How to manage: Error codes....	116
9.2 Function lock.....	104	12.3 Service data.....	117
9.3 Automatic switch-off.....	104	13. ENERGY EFFICIENCY.....	117
9.4 Cooling fan.....	105	13.1 Product Information and Product	
10. HINTS AND TIPS.....	105	Information Sheet.....	117
10.1 Cooking recommendations.....	105	13.2 Energy saving.....	118
10.2 Moist Fan Baking.....	105	14. MENU STRUCTURE.....	119
10.3 Moist Fan Baking -		14.1 Menu.....	119
recommended accessories.....	106	14.2 Submenu for: Cleaning.....	119
10.4 Cooking tables for test institutes	106	14.3 Submenu for: Options.....	120
11. CARE AND CLEANING.....	108	14.4 Submenu for: Setup.....	120
11.1 Notes on cleaning.....	108	14.5 Submenu for: Service.....	121
11.2 How to remove: Shelf supports	109	15. IT'S EASY!.....	121
11.3 How to use: Pyrolytic Cleaning..	109	16. ENVIRONMENTAL CONCERNS.....	122
11.4 Cleaning Reminder.....	110		

1. SAFETY INFORMATION

Before the installation and use of the appliance, carefully read the supplied instructions. The manufacturer is not responsible for any injuries or damage that are the result of incorrect installation or usage. Always keep the instructions in a safe and accessible location for future reference.

1.1 Children and vulnerable people safety

- This appliance can be used by children aged from 8 years and above and persons with reduced physical, sensory or mental capabilities or lack of experience and knowledge if they have been given supervision or instruction concerning the use of the appliance in a safe way and understand the hazards involved. Children of less than 8 years of age and persons with very extensive and complex disabilities shall

be kept away from the appliance unless continuously supervised.

- Children should be supervised to ensure that they do not play with the appliance.
- Keep all packaging away from children and dispose of it appropriately.
- **WARNING:** The appliance and its accessible parts become hot during use. Keep children and pets away from the appliance when in use and when cooling down.
- If the appliance has a child safety device, it should be activated.
- Children shall not carry out cleaning and user maintenance of the appliance without supervision.

1.2 General Safety

- This appliance is for cooking purposes only.
- This appliance is designed for single household domestic use in an indoor environment.
- This appliance may be used in, offices, hotel guest rooms, bed & breakfast guest rooms, farm guest houses and other similar accommodation where such use does not exceed (average) domestic usage levels.
- Only a qualified person must install this appliance and replace the cable.
- Do not use the appliance before installing it in the built-in structure.
- Disconnect the appliance from the power supply before carrying out any maintenance.
- If the mains power supply cable is damaged, it must be replaced by the manufacturer, its Authorised Service Centre or similarly qualified persons to avoid an electrical hazard.
- **WARNING:** Ensure that the appliance is switched off before replacing the lamp to avoid the possibility of electric shock.

SAFETY INSTRUCTIONS

- **WARNING:** The appliance and its accessible parts become hot during use. Care should be taken to avoid touching heating elements or the surface of the appliance cavity.
- Always use oven gloves to remove or insert accessories or ovenware.
- Use only the food sensor (core temperature sensor) recommended for this appliance.
- To remove the shelf supports first pull the front of the shelf support and then the rear end away from the side walls. Install the shelf supports in the opposite sequence.
- Do not use a steam cleaner to clean the appliance.
- Do not use harsh abrasive cleaners or sharp metal scrapers to clean the glass door since they can scratch the surface, which may result in shattering of the glass.
- Before pyrolytic cleaning, remove all accessories and excessive deposits/spills from the appliance cavity.

2. SAFETY INSTRUCTIONS

2.1 Installation

**WARNING!**

Only a qualified person must install this appliance.

- Remove all the packaging.
- Do not install or use a damaged appliance.
- Follow the installation instructions supplied with the appliance.
- Always take care when moving the appliance as it is heavy. Always use safety gloves and enclosed footwear.
- Do not pull the appliance by the handle.
- Install the appliance in a safe and suitable place that meets installation requirements.
- Keep the minimum distance from other appliances and units.
- Before mounting the appliance, check if the appliance door opens without restraint.
- The appliance is equipped with an electric cooling system. It must be operated with the electric power supply.
- The built-in unit must meet the stability requirements of DIN 68930.

Cabinet minimum height (Cabinet under the work-top minimum height)	578 (600) mm
Cabinet width	560 mm

Cabinet depth	550 (550) mm
Height of the front of the appliance	594 mm
Height of the back of the appliance	576 mm
Width of the front of the appliance	595 mm
Width of the back of the appliance	559 mm
Depth of the appliance	567 mm
Built in depth of the appliance	546 mm
Depth with open door	1027 mm
Ventilation opening minimum size. Opening placed on the bottom rear side	560x20 mm
Mains supply cable length. Cable is placed in the right corner of the back side	1500 mm
Mounting screws	4x25 mm

2.2 Electrical connection



WARNING!

Risk of fire and electric shock.

- All electrical connections should be made by a qualified electrician.
- The appliance must be earthed.
- Make sure that the parameters on the rating plate are compatible with the electrical ratings of the mains power supply.
- Always use a correctly installed shockproof socket.
- Do not use multi-plug adapters and extension cables.
- Make sure not to cause damage to the mains plug and to the mains cable. Should the mains cable need to be replaced, this must be carried out by our Authorised Service Centre.
- Do not let mains cables touch or come near the appliance door or the niche below the appliance, especially when it operates or the door is hot.
- The shock protection of live and insulated parts must be fastened in such a way that it cannot be removed without tools.
- Connect the mains plug to the mains socket only at the end of the installation. Make sure that there is access to the mains plug after the installation.
- If the mains socket is loose, do not connect the mains plug.
- Do not pull the mains cable to disconnect the appliance. Always pull the mains plug.
- Use only correct isolation devices: line protecting cut-outs, fuses (screw type fuses removed from the holder), earth leakage trips and contactors.

SAFETY INSTRUCTIONS

- The electrical installation must have an isolation device which lets you disconnect the appliance from the mains at all poles. The isolation device must have a contact opening width of minimum 3 mm.
- Fully close the appliance door before you connect the mains plug to the mains socket.
- This appliance is supplied with a main plug and a main cable.

2.3 Use



WARNING!

Risk of injury, burns and electric shock or explosion.

- Do not change the specification of this appliance.
- Make sure that the ventilation openings are not blocked.
- Do not let the appliance stay unattended during operation.
- Deactivate the appliance after each use.
- Be careful when you open the appliance door while the appliance is in operation. Hot air can release.
- Do not operate the appliance with wet hands or when it has contact with water.
- Do not apply pressure on the open door.
- Do not use the appliance as a work surface or as a storage surface.
- Open the appliance door carefully. The use of ingredients with alcohol can cause a mixture of alcohol and air.
- Do not let sparks or open flames to come in contact with the appliance when you open the door.
- Do not put flammable products or items that are wet with flammable products in, near or on the appliance.



WARNING!

Risk of damage to the appliance.

- To prevent damage or discoloration to the enamel:
 - do not put ovenware or other objects in the appliance directly on the bottom.
 - do not put aluminium foil directly on the bottom of cavity of the appliance.
 - do not put water directly into the hot appliance.
 - do not keep moist dishes and food in the appliance after you finish the cooking.
 - be careful when you remove or install the accessories.
- Discoloration of the enamel or stainless steel has no effect on the performance of the appliance.
- Use a deep pan for moist cakes. Fruit juices cause stains that can be permanent.
- Always cook with the appliance door closed.
- If the appliance is installed behind a furniture panel (e.g. a door) make sure the door is never closed when the appliance operates. Heat and moisture can build up behind a closed furniture panel and cause subsequent damage to the appliance, the housing unit or the floor. Do not close the furniture panel until the appliance has cooled down completely after use.

2.4 Care and cleaning



WARNING!

Risk of injury, fire, or damage to the appliance.

- Before maintenance, deactivate the appliance and disconnect the mains plug from the mains socket.

- Make sure the appliance is cold. There is the risk that the glass panels can break.
- Replace immediately the door glass panels when they are damaged. Contact the Authorised Service Centre.
- Be careful when you remove the door from the appliance. The door is heavy!
- Clean regularly the appliance to prevent the deterioration of the surface material.
- Clean the appliance with a moist soft cloth. Use only neutral detergents. Do not use abrasive products, abrasive cleaning pads, solvents or metal objects.
- If you use an oven spray, follow the safety instructions on its packaging.

2.5 Pyrolytic cleaning



WARNING!

Risk of Injury / Fires / Chemical Emissions (Fumes) in Pyrolytic Mode.

- Before carrying out the pyrolytic cleaning and initial preheating remove from the oven cavity:
 - any excess food residues, oil or grease spills / deposits.
 - any removable objects (including shelves, side rails, etc., provided with the appliance) especially any non-stick pots, pans, trays, utensils, etc.
- Read carefully all the instructions for pyrolytic cleaning.
- Keep children away from the appliance while the pyrolytic cleaning operates. The appliance becomes very hot and hot air is released from the front cooling vents.
- Pyrolytic cleaning is a high temperature operation that can release fumes from cooking residues and construction materials, as such consumers are advised to:
 - provide good ventilation during and after the pyrolytic cleaning.
 - provide good ventilation during and after the initial preheating.
- Do not spill or apply water on the oven door during and after the pyrolytic cleaning to avoid damaging the glass panels.
- Fumes released from all pyrolytic ovens / cooking residues as described are not harmful to humans, including children, or persons with medical conditions.
- Keep pets away from the appliance during and after the pyrolytic cleaning and initial preheating. Small pets (especially birds and reptiles) can be highly sensitive to temperature changes and emitted fumes.
- Non-stick surfaces on pots, pans, trays, utensils etc., can be damaged by the high temperature pyrolytic cleaning operation of all pyrolytic ovens and can be also a source for low level harmful fumes.

2.6 Steam Cooking



WARNING!

Risk of burns and damage to the appliance.

- Released Steam can cause burns:
 - Be careful when you open the appliance door when the function is activated. Steam can release.
 - Open the appliance door with care after the steam cooking operation.

2.7 Internal lighting



WARNING!

Risk of electric shock.

PRODUCT DESCRIPTION

- Concerning the lamp(s) inside this product and spare part lamps sold separately: These lamps are intended to withstand extreme physical conditions in household appliances, such as temperature, vibration, humidity, or are intended to signal information about the operational status of the appliance. They are not intended to be used in other applications and are not suitable for household room illumination.
- This product contains a light source of energy efficiency class G.
- Use only lamps with the same specifications.

2.8 Service

- To repair the appliance contact the Authorised Service Centre.
- Use original spare parts only.

2.9 Disposal



WARNING!

Risk of injury or suffocation.

- Contact your municipal authority for information on how to dispose of the appliance.
- Disconnect the appliance from the mains supply.
- Cut off the mains electrical cable close to the appliance and dispose of it.
- Remove the door catch to prevent children or pets from becoming trapped in the appliance.

3. PRODUCT DESCRIPTION

3.1 General overview

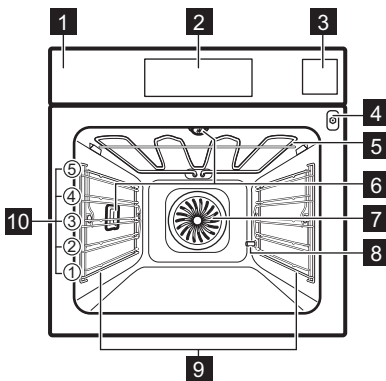

- 1 Control panel
- 2 Display
- 3 Water drawer
- 4 Socket for the food sensor
- 5 Heating element
- 6 Lamp
- 7 Fan
- 8 Descaling pipe outlet
- 9 Shelf support, removable
- 10 Shelf positions

3.2 Accessories

Wire shelf

For cookware, cake tins, roasts.

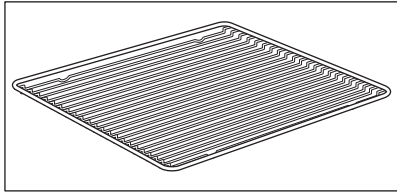

Baking tray

For cakes and biscuits.

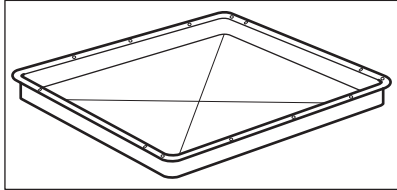

Grill- / Roasting pan

To bake and roast or as a pan to collect fat.

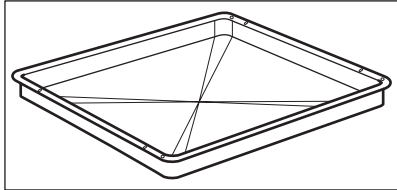

Food sensor

To measure the temperature inside food.

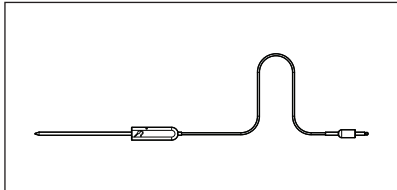

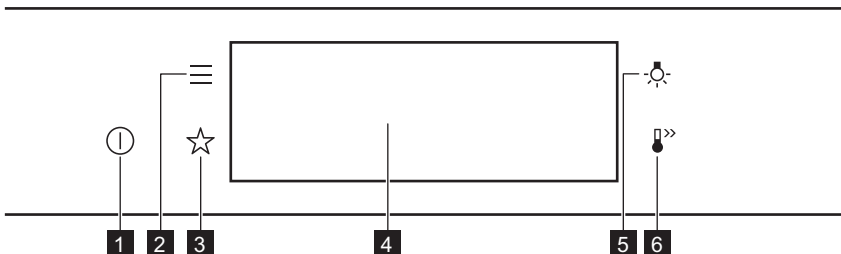

4. CONTROL PANEL

4.1 Control panel overview



CONTROL PANEL



1	ON / OFF	Press and hold to turn the appliance on and off.
2	Menu	Lists the appliance functions.
3	Favourites	Lists the favourite settings.
4	Display	Shows the current settings of the appliance.
5	Lamp switch	To turn the lamp on and off.
6	Fast Heat Up	To turn on and off the function: Fast Heat Up.



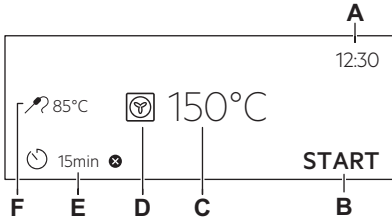

 Press	 Move	 Press and hold
Touch the surface with fingertip.	Slide fingertip over the surface.	Touch the surface for 3 seconds.

4.2 Display

 <p>The diagram shows a control panel display with the following elements: a temperature of 85°C with a question mark icon (labeled F), a timer icon with '15min' (labeled E), a temperature of 150°C with a bird icon (labeled D), a 'START' button (labeled B), and a time of 12:30 (labeled A). A legend on the right explains these indicators.</p>	<p>Display with key functions set.</p> <ul style="list-style-type: none"> A. Time of day B. START/STOP C. Temperature D. Heating functions E. Timer F. Food sensor (selected models only)
-------------------------------------------------------------------------------------------------------------------------------------------------------------------------------------------------------------------------------------------------------------------------------------------------------------------------------------------------------------------------------------------------------------------------------------------	-------------------------------------------------------------------------------------------------------------------------------------------------------------------------------------------------------------------------------------------------------

Display indicators



Basic indicators - to navigate on the display.			
OK To confirm the selection / setting.	 To go one level back in the menu.	 To undo the last action.	 To turn the options on and off.
Sound alarm function indicators - when the set time of cooking ends, the signal sounds.			

 The function is on.	 The function is on. Cooking stops automatically.	 Sound alarm is off.
Timer indicators		
 To set the function: Delayed start.	 To cancel the setting.	

5. BEFORE FIRST USE

 **WARNING!**
Refer to Safety chapters.

5.1 Initial Cleaning

		
Step 1	Step 2	Step 3
Remove all accessories and removable shelf supports from the appliance.	Clean the appliance and the accessories only with a micro-fibre cloth, warm water and a mild detergent.	Place the accessories and the removable shelf supports in the appliance.

5.2 First connection

The display shows welcome message after the first connection.
You have to set: Language, Display brightness, Key tones, Buzzer volume, Water hardness, Time of day.

5.3 Initial preheating

Preheat the empty oven before the first use.





Step 1	Remove all accessories and removable shelf supports from the oven.
Step 2	Set the maximum temperature for the function:  Let the oven operate for 1 h.

BEFORE FIRST USE

Step 3	Set the maximum temperature for the function:  Let the oven operate for 15 min.
<p>i The oven can emit an odour and smoke during preheating. Make sure that the room is ventilated.</p>	

5.4 How to set: Water hardness

When you connect the oven to the mains you have to set the water hardness level. Use the test paper or contact your water supplier to check the water hardness level.

			
Step 1	Step 2	Step 3	Step 4
Put the test paper into water for about 1 sec. Do not put the test paper under running water.	Shake the test paper to remove the excess of water.	After 1 min, check water hardness with the table below.	Set the water hardness level: Menu / Settings / Setup / Water hardness.

<p>i The colours of the test paper continue to change. Do not check water hardness later than 1 min after test.</p>			
<p>You can change the water hardness level in the menu: Settings / Setup / Water hardness.</p>			

The table shows water hardness range (dH) with the corresponding level of Calcium deposit and the water classification. Adjust the water hardness level according to the table.

Water hardness		Test paper	Calcium deposit (mmol/l)	Calcium deposit (mg/l)	Water classification
Level	dH				
1	0 - 7	<div style="border: 1px solid black; width: 100px; height: 15px; margin-bottom: 2px;"></div> <div style="background-color: black; width: 10px; height: 15px; margin-bottom: 2px;"></div> <div style="border: 1px solid black; width: 100px; height: 15px;"></div>	0 - 1.3	0 - 50	soft
2	8 - 14	<div style="background-color: black; width: 15px; height: 15px; margin-right: 5px;"></div> <div style="background-color: black; width: 15px; height: 15px; margin-right: 5px;"></div> <div style="border: 1px solid black; width: 100px; height: 15px;"></div>	1.4 - 2.5	51 - 100	moderately hard
3	15 - 21	<div style="background-color: black; width: 15px; height: 15px; margin-right: 5px;"></div> <div style="background-color: black; width: 15px; height: 15px; margin-right: 5px;"></div> <div style="background-color: black; width: 15px; height: 15px; margin-right: 5px;"></div> <div style="border: 1px solid black; width: 100px; height: 15px;"></div>	2.6 - 3.8	101 - 150	hard
4	≥22	<div style="background-color: black; width: 15px; height: 15px; margin-right: 5px;"></div> <div style="background-color: black; width: 15px; height: 15px; margin-right: 5px;"></div> <div style="background-color: black; width: 15px; height: 15px; margin-right: 5px;"></div> <div style="background-color: black; width: 15px; height: 15px; margin-right: 5px;"></div> <div style="border: 1px solid black; width: 100px; height: 15px;"></div>	≥ 3.9	≥151	very hard

When the tap water hardness level is 4, fill the water drawer with still bottled water.

6. DAILY USE



WARNING!

Refer to Safety chapters.

6.1 How to set: Heating functions

Step 1	Turn on the oven. The display shows the default heating function.
Step 2	Press the symbol of the heating function to enter the submenu.
Step 3	Select the heating function and press: OK . The display shows: temperature.
Step 4	Set: temperature. Press: OK .
Step 5	Press: START . Food Sensor - you can plug the sensor at any time before or during cooking.
STOP - press to turn off the heating function.	
Step 6	Turn off the oven.

6.2 How to set: Steam heating function

Step 1	Turn on the oven. Select the symbol of the heating function and press it to enter the submenu.
Step 2	Press  . Set the steam heating function.
Step 3	Press: OK . The display shows the temperature settings.
Step 4	Set the temperature.
Step 5	Press: OK .
Step 6	Press the cover of the water drawer to open it.

<p>Step 7</p>	<p>Fill the water drawer with cold water to the maximum level (around 950 ml) until the signal sounds or the display shows the message. Do not fill the water drawer over its maximum capacity. There is a risk of water leakage, overflow and furniture damage.</p> <div style="border: 1px solid black; padding: 5px; margin-top: 10px;"> <p> WARNING! Use only cold tap water. Do not use filtered (demineralised) or distilled water. Do not use other liquids. Do not pour flammable or alcoholic liquids into the water drawer.</p> </div>
<p>Step 8</p>	<p>Push the water drawer to its initial position.</p>
<p>Step 9</p>	<p>Press: START . Steam appears after approximately 2 min. When the oven reaches the set temperature, the signal sounds.</p>
<p>Step 10</p>	<p>When the water drawer runs out of water, the signal sounds. Refill the water drawer.</p>
<p>Step 11</p>	<p>Turn off the oven.</p>
<p>Step 12</p>	<p>Empty the water drawer after cooking ends. Refer to "Care and Cleaning" chapter, Tank emptying.</p>
<p>Step 13</p>	<p>Residual water can condensate in the cavity. After cooking, carefully open the oven door. When the oven is cold, dry the cavity with a soft cloth.</p>

6.3 How to set: Assisted Cooking



Every dish in this submenu has a recommended function and temperature. You can adjust the time and the temperature.

For some of the dishes you can also cook with:

- Weight Automatic
- Food Sensor

The degree to which a dish is cooked:

- Rare or Less
- Medium
- Well done or More









<p>Step 1</p>	<p>Turn on the oven.</p>
<p>Step 2</p>	<p>Press: .</p>
<p>Step 3</p>	<p>Press:  . Enter: Assisted Cooking.</p>
<p>Step 4</p>	<p>Choose a dish or a food type.</p>

Step 5









Press: START .

6.4 Heating functions



STANDARD

Heating function	Application
 <p>Grill</p>	To grill thin pieces of food and to toast bread.
 <p>Turbo Grilling</p>	To roast large meat joints or poultry with bones on one shelf position. To make gratins and to brown.
 <p>True Fan Cooking</p>	To bake on up to three shelf positions at the same time and to dry food. Set the temperature 20 - 40 °C lower than for Conventional Cooking.
 <p>Frozen Foods</p>	To make convenience food (e.g., french fries, potato wedges or spring rolls) crispy.
 <p>Conventional Cooking</p>	To bake and roast food on one shelf position.
 <p>Pizza Function</p>	To bake pizza. To make intensive browning and a crispy bottom.
 <p>Bottom Heat</p>	To bake cakes with crispy bottom and to preserve food.
 <p>Dough Proving</p>	To speed up the rising of the yeast dough. It prevents dough surface from drying and keeps the dough elastic.

SPECIALS

Heating function	Application
 <p>Preserving</p>	<p>To preserve vegetables (e.g., pickles).</p>
 <p>Dehydrating</p>	<p>To dry sliced fruit, vegetables and mushrooms.</p>
 <p>Plate Warming</p>	<p>To preheat plates for serving.</p>
 <p>Defrost</p>	<p>To defrost food (vegetables and fruit). The defrosting time depends on the amount and size of the frozen food.</p>
 <p>Au Gratin</p>	<p>For dishes such as lasagna or potato gratin. To make gratins and to brown.</p>
 <p>Slow Cooking</p>	<p>To prepare tender, succulent roasts.</p>
 <p>Keep Warm</p>	<p>To keep food warm.</p>
 <p>Moist Fan Baking</p>	<p>This function is designed to save energy during cooking. When you use this function, the temperature in the cavity may differ from the set temperature. The residual heat is used. The heating power may be reduced. For more information refer to "Daily Use" chapter, Notes on: Moist Fan Baking.</p>

STEAM

Heating function	Application
 <p>Steam Regenerating</p>	Food reheating with steam prevents surface drying. Heat is distributed in a gentle and even way, which allows to recover taste and aroma of food as just prepared. This function can be used to reheat food directly on a plate. You can reheat more than one plate at the same time, using different shelf positions.
 <p>Bread Baking</p>	Use this function to prepare bread and bread rolls with a very good professional-like result in terms of crispiness, colour and crust gloss.
 <p>Humidity Low</p>	The function is suitable for meat, poultry, oven dishes and casseroles. Thanks to the combination of steam and heat, meat gets a tender and juicy texture along with a crusty surface.

6.5 Notes on: Moist Fan Baking

This function was used to comply with the energy efficiency class and ecodesign requirements (according to EU 65/2014 and EU 66/2014). Tests according to: IEC/EN 60350-1

The oven door should be closed during cooking so that the function is not interrupted and the oven operates with the highest energy efficiency possible.

When you use this function the lamp automatically turns off after 30 sec.

For the cooking instructions refer to "Hints and tips" chapter, Moist Fan Baking. For general energy saving recommendations refer to "Energy Efficiency" chapter, Energy Saving.

7. CLOCK FUNCTIONS

7.1 Clock functions description

Clock function	Application
Cooking time	To set the length of cooking. Maximum is 23 h 59 min.
End action	To set what happens when the timer ends counting.
Delayed start	To postpone the start and / or end of cooking.
Time extension	To extend cooking time.
Reminder	To set a countdown. Maximum is 23 h 59 min. This function has no effect on the operation of the appliance.

CLOCK FUNCTIONS

Clock function	Application
Uptimer	Monitors how long the function operates. Uptimer - you can turn it on and off.

7.2 How to set: Clock functions

How to set the clock	
Step 1	Press: Time of day.
Step 2	Set the time. Press: OK .

How to set cooking time	
Step 1	Choose the heating function and set the temperature.
Step 2	Press:  .
Step 3	Set the time. Press: OK .

How to choose end option	
Step 1	Choose the heating function and set the temperature.
Step 2	Press:  .
Step 3	Set the cooking time.
Step 4	Press: ● ● ● .
Step 5	Press: End action.
Step 6	Choose the preferred: End action.
Step 7	Press: OK . Repeat the action until the display shows the main screen.

How to delay start of cooking	
Step 1	Set the heating function and the temperature.
Step 2	Press:  .
Step 3	Set the cooking time.
Step 4	Press: ● ● ● .
Step 5	Press: Delayed start.
Step 6	Choose the value.
Step 7	Press: OK. Repeat the action until the display shows the main screen.

How to extend cooking time
When 10% of cooking time is left and the food seems not to be ready, you can extend cooking time. You can also change the heating function.
Press +1min to extend the cooking time.

How to change timer settings	
Step 1	Press:  .
Step 2	Set the timer value.
Step 3	Press: OK.
You can change the set time during cooking at any time.	

8. USING THE ACCESSORIES



WARNING!

Refer to Safety chapters.

8.1 Inserting accessories

A small indentation at the top increases safety. The indentations are also anti-tip devices. The high rim around the shelf prevents cookware from slipping of the shelf.

USING THE ACCESSORIES

Wire shelf:

Push the shelf between the guide bars of the shelf support.

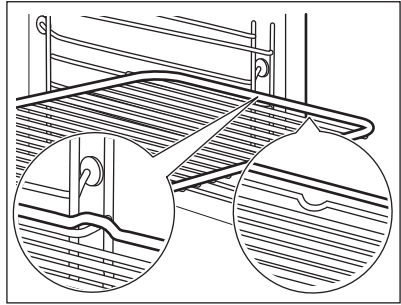

Baking tray / Deep pan:

Push the tray between the guide bars of the shelf support.

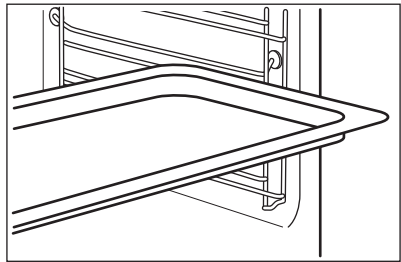

8.2 Food Sensor

Food Sensor - measures the temperature inside the food. You can use it with every heating function.

There are two temperatures to be set:

°C

The oven temperature: minimum 120 °C.



The core temperature.

For the best cooking results:

Ingredients should be at room temperature.

Do not use it for liquid dishes.

During cooking it must remain in the dish.



The oven calculates an approximate end of cooking time. It depends on the quantity of food, the set oven function and the temperature.

8.3 How to use: Food Sensor

Step 1

Turn on the oven.

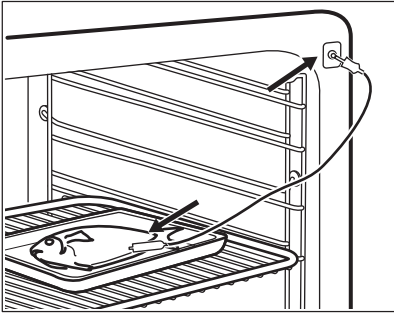
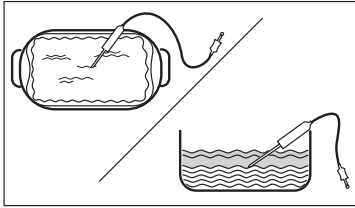
USING THE ACCESSORIES

Step 2	Set a heating function and, if necessary, the oven temperature.
Step 3	Insert: Food Sensor.
Meat, poultry and fish	Casserole
<p>Insert the tip of Food Sensor into the centre of meat, fish, in the thickest part if possible. Make sure that at least 3/4 of Food Sensor is inside of the dish.</p>	<p>Insert the tip of Food Sensor exactly in the centre of the casserole. Food Sensor should be stabilized in one place during baking. Use a solid ingredient to achieve that. Use the rim of the baking dish to support the silicone handle of Food Sensor. The tip of Food Sensor should not touch the bottom of a baking dish.</p>
	
Step 4	<p>Plug Food Sensor into the socket at the front of the oven. The display shows the current temperature of: Food Sensor.</p>
Step 5	<p> - press to set the core temperature of the sensor.</p>
Step 6	<p>● ● ● - press to set the preferred option:</p> <ul style="list-style-type: none"> • Sound alarm - when food reaches the core temperature, the signal sounds. • Sound alarm and stop cooking - when food reaches the core temperature, the signal sounds and the oven stops.
Step 7	<p>Select the option and repeatedly press: OK to go to main screen.</p>
Step 8	<p>Press: START.</p> <p>When food reaches the set temperature, the signal sounds. You can choose to stop or to continue cooking to make sure the food is well done.</p>



ADDITIONAL FUNCTIONS

Step 9	Remove Food Sensor plug from the socket and remove the dish from the oven. <div style="border: 1px solid black; padding: 5px;"> WARNING! There is a risk of burns as Food Sensor becomes hot. Be careful when you unplug it and remove it from the food.</div>
---------------	---------------------------------------------------------------------------------------------------------------------------------------------------------------------------------------------------------------------------------------------------------------------------------------------------------------------------------------------------------------

9. ADDITIONAL FUNCTIONS



9.1 How to save: Favourites

You can save your favourite settings, such as the heating function, the cooking time, the temperature or the cleaning function. You can save 3 favourite settings.

Step 1	Turn on the appliance.
Step 2	Select the preferred setting.
Step 3	Press:  . Select: Favourites.
Step 4	Select: Save current settings.
Step 5	Press + to add the setting to the list of: Favourites. Press OK .
 - press to reset the setting.  - press to cancel the setting.	



9.2 Function lock

This function prevents an accidental change of the heating function.

Step 1	Turn on the appliance.
Step 2	Set a heating function.
Step 3	 ,  - press at the same time to turn on the function.
To turn off the function repeat step 3.	

9.3 Automatic switch-off

For safety reasons the appliance turns off after some time, if a heating function works and you do not change any settings.

 (°C)	 (h)
30 - 115	12.5
120 - 195	8.5
200 - 245	5.5
250 - maximum	3

The Automatic switch-off does not work with the functions: Light, Food sensor, End time, Slow Cooking.

9.4 Cooling fan

When the appliance operates, the cooling fan turns on automatically to keep the surfaces of the appliance cool. If you turn off the appliance, the cooling fan can continue to operate until the appliance cools down.





10. HINTS AND TIPS

10.1 Cooking recommendations







<p>The temperature and cooking times in the tables are guidelines only. They depend on the recipes and the quality and quantity of the ingredients used.</p> <p>Your appliance may bake or roast differently to the appliance you had before. The hints below show recommended settings for temperature, cooking time and shelf position for specific types of the food.</p> <p>If you cannot find the settings for a special recipe, look for the similar one.</p> <p>For more cooking recommendations refer to cooking tables on our website. To find the Cooking Hints, check the PNC number on the rating plate on the front frame of the appliance cavity.</p>

10.2 Moist Fan Baking

For the best results follow suggestions listed in the table below.



		 (°C)		 (min)
Sweet rolls, 16 pieces	baking tray or dripping pan	180	2	25 - 35

HINTS AND TIPS

		 (°C)		 (min)
Swiss Roll	baking tray or dripping pan	180	2	15 - 25
Whole fish, 0.2 kg	baking tray or dripping pan	180	3	15 - 25
Cookies, 16 pieces	baking tray or dripping pan	180	2	20 - 30
Macaroons, 24 pieces	baking tray or dripping pan	160	2	25 - 35
Muffins, 12 pieces	baking tray or dripping pan	180	2	20 - 30
Savory pastry, 20 pieces	baking tray or dripping pan	180	2	20 - 30
Short crust biscuits, 20 pieces	baking tray or dripping pan	140	2	15 - 25
Tartlets, 8 pieces	baking tray or dripping pan	180	2	15 - 25

10.3 Moist Fan Baking - recommended accessories

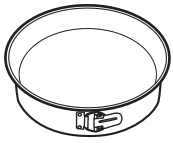
Use the dark and non-reflective tins and containers. They have better heat absorption than the light colour and reflective dishes.

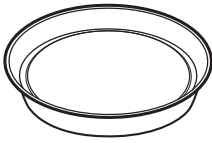



			
Pizza pan	Baking dish	Ramekins	Flan base tin
Dark, non-reflective 28 cm diameter	Dark, non-reflective 26 cm diameter	Ceramic 8 cm diameter, 5 cm height	Dark, non-reflective 28 cm diameter

10.4 Cooking tables for test institutes

Information for test institutes





Tests according to: EN 60350, IEC 60350.

Baking on one level - baking in tins





		 °C	 min	
Fatless sponge cake	True Fan Cooking	160	45 - 60	2
Fatless sponge cake	Conventional Cooking	160	45 - 60	2
Apple pie, 2 tins Ø20 cm	True Fan Cooking	160	55 - 65	2
Apple pie, 2 tins Ø20 cm	Conventional Cooking	180	55 - 65	1
Short bread	True Fan Cooking	140	25 - 35	2
Short bread	Conventional Cooking	140	25 - 35	2

Baking on one level - biscuits





Use the third shelf position.

		 °C	 min
Small cakes, 20 per tray, preheat the empty oven	True Fan Cooking	150	20 - 30
Small cakes, 20 per tray, preheat the empty oven	Conventional Cooking	170	20 - 30

Multilevel baking - biscuits

		 °C	 min	
Short bread	True Fan Cooking	140	25 - 45	2 / 4





CARE AND CLEANING

		 °C	 min	
Small cakes, 20 per tray, preheat the empty oven	True Fan Cooking	150	25 - 35	1 / 4
Fatless sponge cake	True Fan Cooking	160	45 - 55	2 / 4
Apple pie, 1 tin per grid (Ø 20 cm)	True Fan Cooking	160	55 - 65	2 / 4

Grill

Preheat the empty oven for 5 minutes.

Grill with the maximum temperature setting.

		 min	
Toast	Grill	1 - 2	5
Beef steak, turn halfway through	Grill	24 - 30	4

11. CARE AND CLEANING





WARNING!

Refer to Safety chapters.

11.1 Notes on cleaning

 Cleaning Agents	Clean the front of the appliance only with a microfibre cloth with warm water and a mild detergent.
	Use a cleaning solution to clean metal surfaces.
	Clean stains with a mild detergent.

 Everyday Use	<p>Clean the cavity after each use. Fat accumulation or other residue may cause fire.</p>
	<p>Do not store the food in the appliance for longer than 20 minutes. Dry the cavity only with a microfibre cloth after each use.</p>

 Accessories	<p>Clean all accessories after each use and let them dry. Use only a microfibre cloth with warm water and a mild detergent. Do not clean the accessories in a dishwasher.</p>
	<p>Do not clean the non-stick accessories using abrasive cleaner or sharp-edged objects.</p>

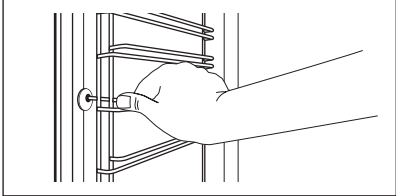

11.2 How to remove: Shelf supports

Remove the shelf supports to clean the oven.

Step 1	Turn off the oven and wait until it is cold.	
Step 2	Carefully pull the shelf supports up and out of the front catch.	
Step 3	Pull the front end of the shelf support away from the side wall.	
Step 4	Pull the supports out of the rear catch.	
<p>Install the shelf supports in the opposite sequence.</p>		

11.3 How to use: Pyrolytic Cleaning

Clean the oven with Pyrolytic Cleaning.

	<p>WARNING! There is a risk of burns.</p>
	<p>CAUTION! If there are other appliances installed in the same cabinet, do not use them at the same time as this function. It can cause damage to the oven.</p>

CARE AND CLEANING

Before the Pyrolytic Cleaning:

Turn off the oven and wait until it is cold.	Remove all accessories.	Clean the oven floor and the inner door glass with warm water, a soft cloth and a mild detergent.
----------------------------------------------	-------------------------	---------------------------------------------------------------------------------------------------

Do not fill the water tank during cleaning. It restarts the cleaning cycle.

Step 1	Turn on the oven.
Step 2	Press:  / Cleaning.
Step 3	Put the baking tray on the first shelf position to collect water from the water tank. OK - press to start water tank emptying.
Step 4	When the tank emptying ends remove the baking tray and removable shelf supports. Wipe the oven cavity and the inner door glass with a soft cloth. Press: OK .
Step 5	Select the cleaning mode.

Option	Cleaning mode	Duration
Pyrolytic cleaning, quick	Light cleaning	1 h
Pyrolytic cleaning, normal	Normal cleaning	1 h 30 min
Pyrolytic cleaning, intense	Thorough cleaning	3 h

 When the cleaning starts, the lamp is off and the cooling fan works at a higher speed.
STOP - press to stop the cleaning before it is completed.
Do not use the oven until the door lock symbol disappears from the display.

When the cleaning ends:

Turn off the oven and wait until it is cold.	Clean the cavity with a soft cloth.	Remove the residue from the bottom of the cavity.
----------------------------------------------	-------------------------------------	---------------------------------------------------

11.4 Cleaning Reminder

When the reminder appears, cleaning is recommended.

Use the function: Pyrolytic Cleaning.

11.5 How to use: Descaling

Before you start:

Turn off the oven and wait until it is cold.	Remove all accessories.	Make sure that the water drawer is empty.
----------------------------------------------	-------------------------	-------------------------------------------

Duration of the first part: around 100 min

Step 1	Place the deep pan on the first shelf position.
Step 2	Pour 250 ml of the descaling agent in the water drawer.
Step 3	Fill the remaining part of the water drawer with water to the maximum level until the signal sounds or the display shows the message.
Step 4	Select: Menu / Cleaning.
Step 5	Turn on the function and follow the instruction on the display. The first part of descaling starts.
Step 6	After the first part is over, empty the deep pan and put it back on the first shelf position.

Duration of the second part: around 35 min

Step 7	Fill the remaining part of the water drawer with water to the maximum level until the signal sounds or the display shows the message.
Step 8	When the function ends, remove the deep pan.

i When this function works, the lamp is off.

When descaling ends:

Turn off the oven.	When the oven is cold, dry the cavity with a soft cloth.	Leave the oven door open and wait until the cavity is dry.
--------------------	----------------------------------------------------------	------------------------------------------------------------

i If some limestone residue remains in the oven after descaling, the display prompts to repeat the procedure.

CARE AND CLEANING

11.6 Descaling reminder

There are two reminders which prompt you to descale the oven. You cannot disable the descaling reminder.

Type	Description
Soft reminder	Recommends you to descale the oven.
Hard reminder	Obligates you to descale the oven. If you do not descale the oven when the hard reminder is on, the steam functions are disabled.

11.7 How to use: Rinsing

Before you start:	
Turn off the oven and wait until it is cold.	Remove all accessories.

Step 1	Place the deep pan on the first shelf position.
Step 2	Fill the water drawer with water to the maximum level until the signal sounds or the display shows the message.
Step 3	Select: Menu / Cleaning / Rinsing. Duration: around 30 min
Step 4	Turn on the function and follow the instruction on the display.
Step 5	When the function ends, remove the deep pan.
 When this function works, the lamp is off.	

11.8 How to use: Tank emptying

Use it after cooking with steam heating function to remove the residual water from the water drawer.

Before you start:	
Turn off the oven and wait until it is cold.	Remove all accessories.

Step 1	Place the deep pan on the first shelf position.
---------------	-------------------------------------------------

Step 2	Select: Menu / Cleaning / Tank emptying. Duration: 6 min
Step 3	Turn on the function and follow the instruction on the display.
Step 4	When the function ends, remove the deep pan.
<p> When this function works, the lamp is off.</p>	

11.9 How to remove and install: Door

You can remove the door and the internal glass panels to clean it. The number of glass panels is different for different models.



WARNING!

The door is heavy.



CAUTION!

Carefully handle the glass, especially around the edges of the front panel. The glass can break.

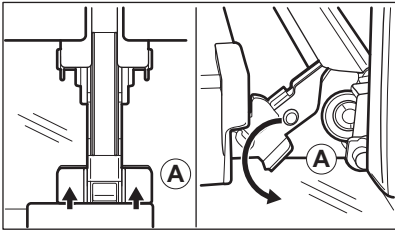
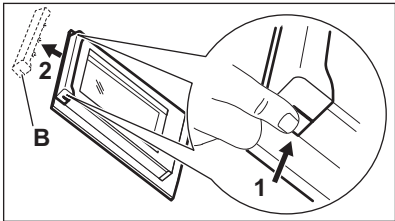
Step 1	Fully open the door.	
Step 2	Lift and press the clamping levers (A) on the two door hinges.	
Step 3	Close the oven door to the first opening position (approximately 70° angle). Hold the door at both sides and pull it away from the oven at an upwards angle. Put the door with the outer side down on a soft cloth on a stable surface.	
Step 4	Hold the door trim (B) on the top edge of the door at the two sides and push inwards to release the clip seal.	
Step 5	Pull the door trim to the front to remove it.	
Step 6	Hold the door glass panels on their top edge one by one and pull them up out of the guide.	

CARE AND CLEANING

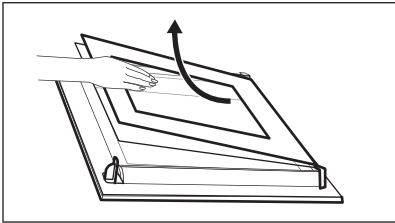
Step 7	Clean the glass panel with water and soap. Dry the glass panel carefully. Do not clean the glass panels in the dishwasher.	
Step 8	After cleaning, do the above steps in the opposite sequence.	
Step 9 Install the smaller panel first, then the larger and the door.		

11.10 How to replace: Lamp

	WARNING! Risk of electric shock. The lamp can be hot.
----------------------------------------------------------------------------------	--------------------------------------------------------------------

Before you replace the lamp:

Step 1	Step 2	Step 3
Turn off the oven. Wait until the oven is cold.	Disconnect the oven from the mains.	Put a cloth on the bottom of the cavity.

Top lamp

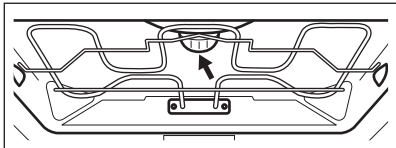
Step 1	Turn the glass cover to remove it.	
Step 2	Remove the metal ring and clean the glass cover.	
Step 3	Replace the lamp with a suitable 300 °C heat-resistant lamp.	
Step 4	Attach the metal ring to the glass cover and install it.	

Side lamp

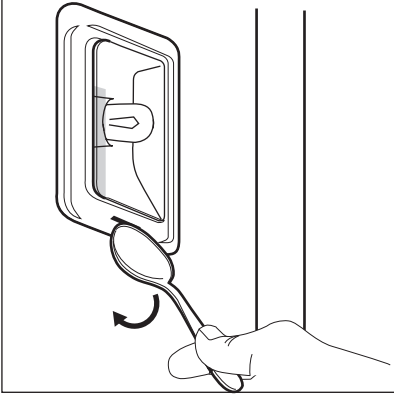
Step 1	Remove the left shelf support to get access to the lamp.	
Step 2	Use a narrow, blunt object (e.g. a teaspoon) to remove the glass cover.	
Step 3	Clean the glass cover.	
Step 4	Replace the lamp with a suitable 300 °C heat-resistant lamp.	
Step 5	Install the glass cover.	
Step 6	Install the left shelf support.	



12. TROUBLESHOOTING





WARNING!



Refer to Safety chapters.

12.1 What to do if...

 The appliance does not turn on or does not heat up	
 Possible cause	 Remedy
The appliance is not connected to an electrical supply or it is connected incorrectly.	Check if the appliance is correctly connected to the electrical supply.
The clock is not set.	Set the clock, for details refer to Clock functions chapter, How to set: Clock functions.
The door is not closed correctly.	Fully close the door.
The fuse is blown.	Make sure the fuse is the cause of the problem. If the problem recurs, contact a qualified electrician.

TROUBLESHOOTING



 The appliance does not turn on or does not heat up	
 Possible cause	 Remedy
The appliance Child Lock is on.	Refer to "Menu" chapter, Submenu for: Options.

 Components	
 Description	 Remedy
The lamp is burnt out.	Replace the lamp, for details refer to "Care and Cleaning" chapter, How to replace: Lamp.

Power cut always stops cleaning. Repeat cleaning if it's interrupted by power failure.

12.2 How to manage: Error codes

When the software error occurs, the display shows error message. In this section, you will find the list of the problems that you can handle on your own.

 Code and description	 Remedy
C2 - the Food sensor is in the appliance cavity during Pyrolytic Cleaning.	Take out the Food sensor.
C3 - the door is not fully closed during Pyrolytic Cleaning.	Close the door.
F111 - Food sensor is not correctly inserted into the socket.	Fully plug Food sensor into the socket.
F240, F439 - the touch fields on the display do not work properly.	Clean the surface of the display. Make sure there is no dirt on the touch fields.
F908 - the appliance system cannot connect with the control panel.	Turn the appliance off and on.

12.3 Service data

If you cannot find a solution to the problem yourself, contact your dealer or an Authorised Service Centre.

The necessary data for the service centre is on the rating plate. The rating plate is on the front frame of the appliance cavity. Do not remove the rating plate from the appliance cavity.

We recommend that you write the data here:	
Model (MOD.)
Product number (PNC)
Serial number (S.N.)

13. ENERGY EFFICIENCY

13.1 Product Information and Product Information Sheet

Supplier's name	AEG
Model identification	BSE77280M 944188685 BSE77228BM 944188655 BSK772280M 944188643 BSS772280B 944188644
Energy Efficiency Index	61.2
Energy efficiency class	A++
Energy consumption with a standard load, conventional mode	1.09 kWh/cycle
Energy consumption with a standard load, fan-forced mode	0.52 kWh/cycle
Number of cavities	1
Heat source	Electricity
Volume	71 l
Type of oven	Built-In Oven

Mass	BSE772280M	36.0 kg
	BSE77228BM	36.0 kg
	BSK772280M	36.0 kg
	BSS772280B	36.0 kg

IEC/EN 60350-1 - Household electric cooking appliances - Part 1: Ranges, ovens, steam ovens and grills - Methods for measuring performance.

13.2 Energy saving



The appliance has features which help you save energy during everyday cooking.

Make sure that the appliance door is closed when the appliance operates. Do not open the appliance door too often during cooking. Keep the door gasket clean and make sure it is well fixed in its position.

Use metal cookware to improve energy saving.

When possible, do not preheat the appliance before cooking.

Keep breaks between baking as short as possible when you prepare a few dishes at one time.

Cooking with fan

When possible, use the cooking functions with fan to save energy.

Residual heat

If a programme with Duration is activated and the cooking time is longer than 30 min, the heating elements automatically turn off earlier in some appliance functions.

The fan and lamp continue to operate. When you turn off the appliance, the display shows the residual heat. You can use that heat to keep the food warm.

When the cooking duration is longer than 30 min, reduce the appliance temperature to minimum 3 - 10 min before the end of cooking. The residual heat inside the appliance will continue to cook.

Use the residual heat to warm up other dishes.

Keep food warm

Choose the lowest possible temperature setting to use residual heat and keep a meal warm.

The residual heat indicator or temperature appears on the display.

Cooking with the lamp off

Turn off the lamp during cooking. Turn it on only when you need it.

Moist Fan Baking

Function designed to save energy during cooking.

When you use this function the lamp automatically turns off after 30 sec. You may turn on the lamp again but this action will reduce the expected energy savings.

14. MENU STRUCTURE

14.1 Menu

Menu item		Application
Assisted Cooking		Lists automatic programmes.
Cleaning		Lists cleaning programmes.
Favourites		Lists the favourite settings.
Options		To set the appliance configuration.
Settings	Setup	To set the appliance configuration.
	Service	Shows the software version and configuration.

14.2 Submenu for: Cleaning

Submenu	Application
Tank emptying	Procedure for removing the residual water from the water drawer after use of the steam functions.
Pyrolytic cleaning, quick	Duration: 1 h.
Pyrolytic cleaning, normal	Duration: 1 h 30 min.
Pyrolytic cleaning, intense	Duration: 3 h.
Descaling	Procedure for cleaning the steam generation circuit from residual limestone.
Rinsing	Procedure for rinsing and cleaning the steam generation circuit after frequent use of the steam functions.

MENU STRUCTURE

14.3 Submenu for: Options

Submenu	Application
Light	Turns the lamp on and off.
Child Lock	Prevents accidental activation of the appliance. When the option is on, the text Child Lock appears in the display when you turn on the appliance. To enable the appliance use, choose the code letters in the alphabetical order. When the option is on, and the appliance is turned off the appliance door is locked. Access to the timer, the remote operation and the lamp is available with the option on.
Fast Heat Up	Shortens the heat up time. It is available only for some of the appliance functions.
Time indication	Turns the clock on and off.
Digital clock style	Changes the format of the displayed time indication.

14.4 Submenu for: Setup

Submenu	Description
Language	Sets the appliance language.
Display brightness	Sets the display brightness.
Key tones	Turns the tone of the touch fields on and off. It is not possible to mute the tone for: ①.
Buzzer volume	Sets the volume of key tones and signals.
Water hardness	Sets the water hardness.
Time of day	Sets the current time and date.

14.5 Submenu for: Service

Submenu	Description
Demo mode	Activation / deactivation code: 2468
Software version	Information about software version.
Reset all settings	Restores factory settings.

15. IT'S EASY!

Before the first use you have to set:

Language	Display brightness	Key tones	Buzzer volume	Water hardness	Time of day
----------	--------------------	-----------	---------------	----------------	-------------

Start using the appliance

Quick start	Turn on the appliance and start cooking with the default temperature and time of the function.	Step 1	Step 2	Step 3
		Press and hold: ①.	 ... - select the preferred function.	Press: START.
Quick Off	Turn off the appliance, any screen or message at any time.	① - press and hold until the appliance turns off.		



Start cooking

Step 1	Step 2	Step 3	Step 4	Step 5
① - press to turn on the appliance.	 ... - select the heating function.	°C - set the temperature.	OK - press to confirm.	START - press to start cooking.

IT'S EASY!

Get to know how to cook quickly

Use the automatic programmes to prepare a dish quickly with the default settings:

Assisted Cooking	Step 1	Step 2	Step 3	Step 4
	Press:  .	Press:  .	Press:  Assisted Cooking.	Choose the dish.



Use quick functions to set the cooking time

10% Finish assist

Use 10% Finish assist to add extra time when 10% of the cooking time is left.

To extend the cooking time press **+1min**.

16. ENVIRONMENTAL CONCERNS

Recycle materials with the symbol . Put the packaging in relevant containers to recycle it. Help protect the environment and human health by recycling waste of electrical and electronic appliances. Do not dispose of appliances marked with the symbol  with the household waste. Return the product to your local recycling facility or contact your municipal office.

POUR DES RÉSULTATS PARFAITS

Merci d'avoir choisi ce produit AEG. Nous l'avons conçu pour qu'il vous offre des performances irréprochables pendant de nombreuses années, en intégrant des technologies innovantes vous simplifiant la vie – fonctions que vous ne trouverez peut-être pas sur des appareils ordinaires. Veuillez prendre quelques instants pour lire cette notice afin d'utiliser au mieux votre appareil. Consultez notre site pour :



Obtenir des conseils d'utilisation, des brochures, un dépanneur, des informations sur le service et les réparations :

www.aeg.com/support



Enregistrer votre produit pour un meilleur service :

www.registreaeg.com



Acheter des accessoires, consommables et pièces de rechange d'origine pour votre appareil :

www.aeg.com/shop

SERVICE ET ASSISTANCE À LA CLIENTÈLE

N'utilisez que des pièces de rechange d'origine. Avant de contacter notre centre de service agréé, assurez-vous de disposer des informations suivantes : Modèle, PNC, numéro de série. Ces informations figurent sur la plaque signalétique.

 Avertissement/Consignes de sécurité

 Informations générales et conseils

 Informations environnementales

Sous réserve de modifications.

TABLE DES MATIÈRES

1. INFORMATION SUR LA SÉCURITÉ.....	124	3.2 Accessoires.....	131
1.1 Sécurité des enfants et des personnes vulnérables.....	125	4. BANDEAU DE COMMANDE.....	132
1.2 Sécurité générale.....	125	4.1 Vue d'ensemble du bandeau de commande.....	132
2. CONSIGNES DE SÉCURITÉ.....	127	4.2 Affichage.....	133
2.1 Installation.....	127	5. AVANT LA PREMIÈRE UTILISATION....	134
2.2 Branchement électrique.....	128	5.1 Nettoyage initial	134
2.3 Utilisation.....	128	5.2 Première connexion.....	134
2.4 Entretien et Nettoyage.....	129	5.3 Préchauffage initial.....	134
2.5 Nettoyage par pyrolyse.....	130	5.4 Comment régler Dureté de l'eau..	135
2.6 Cuisson à la vapeur.....	130	6. UTILISATION QUOTIDIENNE.....	136
2.7 Éclairage interne.....	130	6.1 Comment régler Modes de cuisson.....	136
2.8 Service.....	131	6.2 Comment régler : Mode de cuisson Vapeur.....	136
2.9 Mise au rebut.....	131		
3. DESCRIPTION DE L'APPAREIL.....	131		
3.1 Vue d'ensemble.....	131		

INFORMATION SUR LA SÉCURITÉ

6.3 Comment régler :		11.3 Comment utiliser : Nettoyage	
Cuisson assistée.....	137	par pyrolyse.....	151
6.4 Modes de cuisson.....	138	11.4 Nettoyage conseillé.....	153
6.5 Remarques sur : Chaleur		11.5 Comment utiliser : Détartrage....	153
Tournante Humide.....	140	11.6 Rappel de détartrage.....	154
7. FONCTIONS DE L'HORLOGE.....	141	11.7 Comment utiliser : Rinçage.....	154
7.1 Description des fonctions de		11.8 Comment utiliser : Vidange	
l'horloge.....	141	du réservoir.....	155
7.2 Comment régler Fonctions		11.9	
de l'horloge.....	141	Comment démonter et installer : Port	
8. UTILISATION DES ACCESSOIRES.....	143	e.....	155
8.1 Insertion des accessoires.....	143	11.10 Comment remplacer :	
8.2 Sonde de cuisson.....	144	Éclairage.....	156
8.3 Comment utiliser : Sonde		12. DÉPANNAGE.....	157
de cuisson.....	144	12.1 Que faire si.....	158
9. FONCTIONS SUPPLÉMENTAIRES.....	145	12.2 Comment gérer : Codes	
9.1 Comment enregistrer :		d'erreur.....	158
Mes programmes.....	145	12.3 Données de maintenance.....	159
9.2 Verrouillage des touches.....	146	13. RENDEMENT ÉNERGÉTIQUE.....	159
9.3 Arrêt automatique.....	146	13.1 Informations produits et fiche	
9.4 Ventilateur de refroidissement....	147	d'informations produits.....	159
10. CONSEILS.....	147	13.2 Économie d'énergie.....	160
10.1 Recommandations de cuisson... 147		14. STRUCTURE DES MENUS.....	161
10.2 Chaleur Tournante Humide.....	147	14.1 Menu	161
10.3 Chaleur Tournante Humide -		14.2 Sous-menu pour : Nettoyage.....	161
accessoires recommandés.....	148	14.3 Sous-menu pour : Options.....	162
10.4 Tableaux de cuisson pour les		14.4 Sous-menu pour : Configuration	162
instituts de tests.....	148	14.5 Sous-menu pour : Service.....	163
11. ENTRETIEN ET NETTOYAGE.....	150	15. C'EST SIMPLE !.....	163
11.1 Remarques concernant le		16. EN MATIÈRE DE PROTECTION DE	
nettoyage.....	150	L'ENVIRONNEMENT.....	164
11.2 Comment retirer : Supports de			
grille	151		

1. ⚠ INFORMATION SUR LA SÉCURITÉ

Avant d'installer et d'utiliser cet appareil, lisez soigneusement les instructions fournies. Le fabricant ne pourra être tenu pour responsable des blessures et dégâts résultant d'une mauvaise installation ou utilisation. Conservez toujours les instructions dans un lieu sûr et accessible pour vous y référer ultérieurement.

1.1 Sécurité des enfants et des personnes vulnérables

- Cet appareil peut être utilisé par des enfants âgés d'au moins 8 ans et par des personnes ayant des capacités physiques, sensorielles ou mentales réduites ou dénuées d'expérience ou de connaissance, s'ils sont correctement surveillés ou si des instructions relatives à l'utilisation de l'appareil en toute sécurité leur ont été données et s'ils comprennent les risques encourus. Les enfants de moins de 8 ans et les personnes ayant un handicap très important et complexe doivent être tenus à l'écart de l'appareil, à moins d'être surveillés en permanence.
- Veillez à ce que les enfants ne jouent pas avec l'appareil.
- Ne laissez pas les emballages à la portée des enfants et jetez-les convenablement.
- **AVERTISSEMENT** : L'appareil et ses parties accessibles deviennent chauds pendant l'utilisation. Tenez les enfants et les animaux éloignés de l'appareil lorsqu'il est en cours d'utilisation et de refroidissement.
- Si l'appareil est équipé d'un dispositif de sécurité enfants, nous vous recommandons de l'activer.
- Le nettoyage et l'entretien par l'utilisateur ne doivent pas être effectués par des enfants sans surveillance.

1.2 Sécurité générale

- Cet appareil est exclusivement destiné à un usage culinaire.
- Cet appareil est conçu pour un usage domestique unique, dans un environnement intérieur.
- Cet appareil peut être utilisé dans les bureaux, les chambres d'hôtel, les chambres d'hôtes, les maisons d'hôtes de ferme et d'autres hébergements similaires lorsque cette utilisation ne dépasse pas le niveau (moyen) de l'utilisation domestique.

INFORMATION SUR LA SÉCURITÉ

- Cet appareil doit être installé et le câble remplacé uniquement par un professionnel qualifié.
- N'utilisez pas l'appareil avant de l'avoir installé dans la structure encastrée.
- Débranchez l'appareil de l'alimentation électrique avant toute opération d'entretien.
- Si le câble d'alimentation secteur est endommagé, son remplacement doit être confié exclusivement au fabricant, à son service après-vente ou à toute autre personne qualifiée afin d'éviter tout danger électrique.
- **AVERTISSEMENT** : Assurez-vous que l'appareil est éteint avant de remplacer l'ampoule pour éviter tout risque d'électrocution.
- **AVERTISSEMENT** : L'appareil et ses parties accessibles deviennent chauds pendant l'utilisation. Des précautions doivent être prises pour éviter de toucher les éléments chauffants ou la surface de la cavité de l'appareil.
- Utilisez toujours des gants de cuisine pour retirer ou insérer des accessoires ou des plats allant au four.
- Utilisez uniquement la sonde de cuisson recommandée pour cet appareil.
- Pour retirer les supports de grille, tirez d'abord l'avant du support de grille, puis l'arrière à distance des parois latérales. Installez les supports de grille dans l'ordre inverse.
- N'utilisez pas de nettoyeur à vapeur pour nettoyer l'appareil.
- N'utilisez pas de produits abrasifs ni de racloirs pointus en métal pour nettoyer la porte en verre car ils peuvent rayer la surface, ce qui peut briser le verre.
- Avant le nettoyage par pyrolyse, retirez tous les accessoires et les dépôts/déversements excessifs de la cavité de l'appareil.

2. CONSIGNES DE SÉCURITÉ

2.1 Installation



AVERTISSEMENT!

L'appareil doit être installé uniquement par un professionnel qualifié.

- Retirez l'intégralité de l'emballage.
- N'installez pas et ne branchez pas un appareil endommagé.
- Suivez scrupuleusement les instructions d'installation fournies avec l'appareil.
- Soyez toujours vigilants lorsque vous déplacez l'appareil car il est lourd. Utilisez toujours des gants de sécurité et des chaussures fermées.
- Ne tirez jamais l'appareil par la poignée.
- Installez l'appareil dans un lieu sûr et adapté répondant aux exigences d'installation.
- Respectez l'espacement minimal requis par rapport aux autres appareils et éléments.
- Avant de monter l'appareil, vérifiez si la porte de l'appareil s'ouvre sans retenue.
- L'appareil est équipé d'un système de refroidissement électrique. Il doit être utilisé avec l'alimentation électrique.
- L'unité intégrée doit répondre aux exigences de stabilité de la norme DIN 68930.

Hauteur minimale du meuble (Hauteur minimale du meuble sous le plan de travail)	578 (600) mm
Largeur du meuble	560 mm
Profondeur du meuble	550 (550) mm
Hauteur de l'avant de l'appareil	594 mm
Hauteur de l'arrière de l'appareil	576 mm
Largeur de l'avant de l'appareil	595 mm
Largeur de l'arrière de l'appareil	559 mm
Profondeur de l'appareil	567 mm
Profondeur d'encastrement de l'appareil	546 mm
Profondeur avec porte ouverte	1027 mm
Dimensions minimales de l'ouverture de ventilation. Ouverture placée sur la partie inférieure de la face arrière	560x20 mm
Longueur du câble d'alimentation secteur. Le câble est placé dans le coin droit de la face arrière	1500 mm

CONSIGNES DE SÉCURITÉ

Vis de montage	4x25 mm
----------------	---------

2.2 Branchement électrique



AVERTISSEMENT!

Risque d'incendie ou d'électrocution.

- Tous les raccordements électriques doivent être effectués par un électricien qualifié.
- L'appareil doit être relié à la terre.
- Assurez-vous que les paramètres figurant sur la plaque signalétique correspondent aux données électriques nominale de l'alimentation secteur.
- Utilisez toujours une prise de courant de sécurité correctement installée.
- N'utilisez pas d'adaptateurs multiprise et de rallonges.
- Veillez à ne pas endommager la fiche secteur ni le câble d'alimentation. Le remplacement du câble d'alimentation de l'appareil doit être effectué par notre service après-vente agréé.
- Ne laissez pas les câbles d'alimentation entrer en contact ou s'approcher de la porte de l'appareil ou de la niche d'encastrement sous l'appareil, particulièrement lorsqu'il est en marche ou que la porte est chaude.
- La protection contre les chocs des parties sous tension et isolées doit être fixée de telle manière qu'elle ne puisse pas être enlevée sans outils.
- Ne branchez la fiche secteur dans la prise secteur qu'à la fin de l'installation. Assurez-vous que la prise secteur est accessible après l'installation.
- Si la prise secteur est détachée, ne branchez pas la fiche secteur.
- Ne tirez pas sur le câble secteur pour débrancher l'appareil. Tirez toujours sur la fiche de la prise secteur.
- N'utilisez que des systèmes d'isolation appropriés : des coupe-circuits, des fusibles (les fusibles à visser doivent être retirés du support), un disjoncteur différentiel et des contacteurs.
- L'installation électrique doit comporter un dispositif d'isolation qui vous permet de déconnecter l'appareil du secteur à tous les pôles. Le dispositif d'isolement doit avoir une largeur d'ouverture de contact de 3 mm minimum.
- Fermez bien la porte de l'appareil avant de brancher la fiche à la prise secteur.
- Cet appareil est fourni avec une fiche électrique et un câble d'alimentation.

2.3 Utilisation



AVERTISSEMENT!

Risque de blessures, de brûlures, d'électrocution ou d'explosion.

- Ne modifiez pas les spécifications de cet appareil.
- Assurez-vous que les orifices d'aération ne sont pas obstrués.
- Ne laissez pas l'appareil sans surveillance durant son fonctionnement.
- Éteignez l'appareil après chaque utilisation.
- Soyez prudent lors de l'ouverture de la porte de l'appareil lorsque celui-ci fonctionne. De l'air chaud peut se dégager.
- N'utilisez pas l'appareil avec des mains mouillées ou en contact avec de l'eau.
- N'exercez pas de pression sur la porte ouverte.
- N'utilisez pas l'appareil comme plan de travail ou comme espace de rangement.

- Ouvrez la porte de l'appareil avec précaution. L'utilisation d'ingrédients avec de l'alcool peut provoquer un mélange d'alcool et d'air.
- Ne laissez pas des étincelles ou des flammes nues entrer en contact avec l'appareil lorsque vous ouvrez la porte.
- Ne placez pas de produits inflammables ou d'éléments imbibés de produits inflammables à l'intérieur, à proximité ou au-dessus de l'appareil.



AVERTISSEMENT!

Risque d'endommagement de l'appareil.

- Pour éviter tout endommagement ou décoloration de l'émail :
 - ne posez pas de plats allant au four ou d'autres objets directement dans le fond de l'appareil.
 - ne placez jamais de feuilles d'aluminium directement sur le fond de la cavité de l'appareil.
 - ne versez pas d'eau directement dans l'appareil chaud.
 - ne conservez pas de plats et de nourriture humides dans l'appareil après avoir terminé la cuisson.
 - Installez ou retirez les accessoires avec précautions.
- La décoloration de l'émail ou de l'acier inoxydable est sans effet sur les performances de l'appareil.
- Utilisez un plat à rôtir pour des gâteaux moelleux. Les jus de fruits provoquent des taches qui peuvent être permanentes.
- Cuisinez toujours avec la porte de l'appareil fermée.
- Si l'appareil est installé derrière la paroi d'un meuble (par ex. une porte), veuillez à ce que la porte ne soit jamais fermée lorsque l'appareil fonctionne. La chaleur et l'humidité peuvent s'accumuler derrière la porte fermée du meuble et provoquer d'importants dégâts sur l'appareil, votre logement ou le sol. Ne fermez pas la paroi du meuble tant que l'appareil n'a pas refroidi complètement.

2.4 Entretien et Nettoyage



AVERTISSEMENT!

Risque de blessure, d'incendie ou de dommages matériels sur l'appareil.

- Avant toute opération d'entretien, éteignez l'appareil et débranchez la fiche de la prise secteur.
- Vérifiez que l'appareil est froid. Les panneaux de verre risquent de se briser.
- Remplacez immédiatement les vitres de la porte si elles sont endommagées. Contactez le service après-vente agréé.
- Soyez prudent lorsque vous retirez la porte de l'appareil. La porte est lourde !
- Nettoyez régulièrement l'appareil afin de maintenir le revêtement en bon état.
- Nettoyez l'appareil avec un chiffon doux humide. Utilisez uniquement des produits de lavage neutres. N'utilisez pas de produits abrasifs, de tampons à récurer, de solvants ni d'objets métalliques.
- Si vous utilisez un spray pour four, suivez les consignes de sécurité figurant sur son emballage.

2.5 Nettoyage par pyrolyse



AVERTISSEMENT!

Risque de blessures, d'incendie, d'émissions chimiques (fumées) en mode pyrolyse.

- Avant d'effectuer un nettoyage par pyrolyse et un préchauffage initial, retirez de la cavité du four :
 - tout résidu alimentaire excessif, déversement et dépôt d'huile ou de graisse.
 - tous les objets amovibles (y compris les grilles, les rails latéraux, etc., fournis avec l'appareil), en particulier les casseroles, poêles, plateaux, ustensiles anti-adhésifs, etc.
- Lisez attentivement toutes les instructions relatives au nettoyage par pyrolyse.
- Tenez les jeunes enfants éloignés de l'appareil lorsque le nettoyage par pyrolyse est en cours. L'appareil devient très chaud et de l'air chaud est libéré des orifices d'aération avant.
- Le nettoyage par pyrolyse est un fonctionnement à haute température qui peut dégager de la fumée provenant des résidus de cuisson et des matériaux de construction. Par conséquent, il est recommandé aux consommateurs de :
 - veillez à assurer une bonne ventilation pendant et après le nettoyage par pyrolyse.
 - veillez à assurer une bonne ventilation pendant et après le préchauffage initial.
- Ne renversez pas ou n'appliquez pas d'eau sur la porte du four pendant et après le nettoyage par pyrolyse pour éviter d'endommager les panneaux de verre.
- Les fumées dégagées par les fours à pyrolyse / les résidus de cuisson sont décrites comme étant non nocives pour les êtres humains, y compris pour les jeunes ou les personnes à la santé fragile.
- Maintenez les animaux domestiques à l'écart de l'appareil pendant et après le nettoyage par pyrolyse et le préchauffage initial. Les petits animaux de compagnie (en particulier les oiseaux et les reptiles) peuvent être très sensibles aux changements de température et aux fumées émises.
- Les surfaces anti-adhésives des casseroles, des poêles, des plaques, des ustensiles, etc. peuvent être endommagées par le nettoyage par pyrolyse à haute température et peuvent également être source de fumées légèrement nocives.

2.6 Cuisson à la vapeur



AVERTISSEMENT!

Risque de brûlures et de dommages matériels à l'appareil.

- La vapeur qui s'échappe peut provoquer des brûlures :
 - Soyez prudent lors de l'ouverture de la porte de l'appareil lorsque cette fonction est activée. De la vapeur peut s'échapper.
 - Soyez prudent en ouvrant la porte de l'appareil après une cuisson à la vapeur.

2.7 Éclairage interne



AVERTISSEMENT!

Risque d'électrocution !

- Concernant la/les lampe(s) à l'intérieur de ce produit et les lampes de rechange vendues séparément : Ces lampes sont conçues pour résister à des conditions physiques extrêmes dans les appareils électroménagers, telles que la température, les vibrations, l'humidité, ou sont conçues pour signaler des informations sur le statut opérationnel de l'appareil. Elles ne sont pas destinées à être utilisées dans d'autres applications et ne conviennent pas à l'éclairage des pièces d'un logement.

- Ce produit contient une source lumineuse de classe d'efficacité énergétique G.
- Utilisez uniquement des ampoules ayant les mêmes spécifications.

2.8 Service

- Pour réparer l'appareil, contactez le service après-vente agréé.
- Utilisez uniquement des pièces de rechange d'origine.

2.9 Mise au rebut



AVERTISSEMENT!

Risque de blessure ou d'asphyxie.

- Contactez votre service municipal pour obtenir des informations sur la marche à suivre pour mettre l'appareil au rebut.
- Débranchez l'appareil de l'alimentation électrique.
- Coupez le câble d'alimentation au ras de l'appareil et mettez-le au rebut.
- Retirez le dispositif de verrouillage du hublot pour empêcher les jeunes et les animaux de s'enfermer dans l'appareil.

3. DESCRIPTION DE L'APPAREIL

3.1 Vue d'ensemble

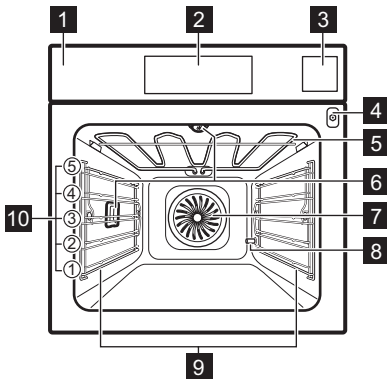

- 1 Bandeau de commande
- 2 Affichage
- 3 Bac à eau
- 4 Prise pour la sonde à viande
- 5 Résistance
- 6 Éclairage
- 7 Chaleur tournante
- 8 Sortie du tuyau de détartrage
- 9 Support de grille, amovible
- 10 Niveaux de la grille

3.2 Accessoires

Grille métallique

Pour les plats de cuisson, les moules à gâteaux, les rôtis.

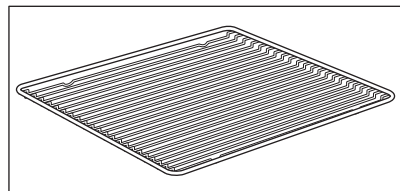

BANDEAU DE COMMANDE

Plateau de cuisson

Pour les gâteaux et biscuits.

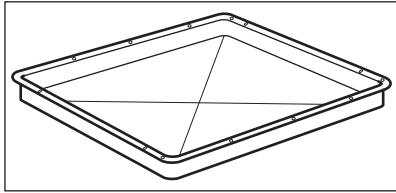

Plat à rôtir

Pour cuire et rôtir ou comme plat pour récupérer la graisse.

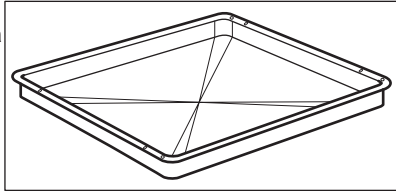

Sonde de cuisson

Pour mesurer la température à l'intérieur des aliments.

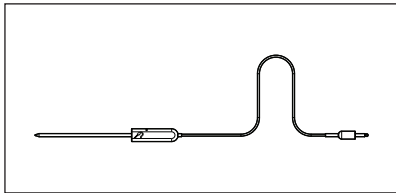

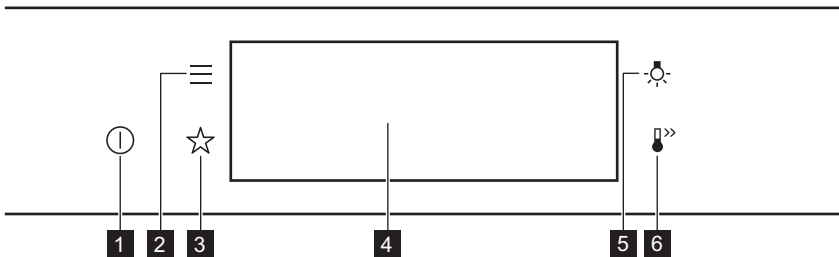

4. BANDEAU DE COMMANDE

4.1 Vue d'ensemble du bandeau de commande



1	Activez / Désactivez	Appuyez et maintenez enfoncé pour allumer et éteindre l'appareil.
2	Menu	Répertorie les fonctions de l'appareil.
3	Mes programmes	Indique les réglages favoris.



4	Affichage	Affiche les réglages actuels de l'appareil.
5	Curseur de l'éclairage	Pour allumer et éteindre l'éclairage.
6	Préchauffage rapide	Pour activer et désactiver la fonction : Préchauffage rapide.

		
Appuyez sur la touche	Déplacez	Maintenez la touche
Appuyez sur la surface du bout du doigt.	Faites glisser le bout de votre doigt sur la surface.	Appuyez sur la surface pendant 3 secondes.

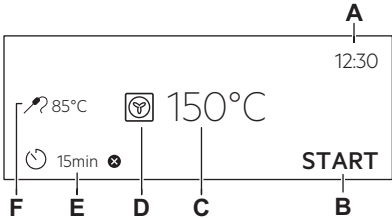



4.2 Affichage

	<p>Affichage avec les principales fonctions réglées</p> <ul style="list-style-type: none"> A. Heure actuelle B. DEMARRER/ARRETER C. Température D. Modes de cuisson E. Minuteur F. Sonde de cuisson (uniquement sur certains modèles)
-----------------------------------------------------------------------------------	---------------------------------------------------------------------------------------------------------------------------------------------------------------------------------------------------------------------------------------------------------------------------------------------------

Voyants de l'affichage

Indicateurs de base - pour naviguer dans l'affichage.			
<p>OK</p> <p>Pour confirmer la sélection/le réglage.</p>	<p></p> <p>Pour remonter d'un niveau dans le menu.</p>	<p></p> <p>Pour annuler la dernière action.</p>	<p></p> <p>Pour activer et désactiver les options.</p>
<p>Son alarme indicateurs de fonction - lorsque la durée de cuisson programmée s'est écoulée, le signal sonore retentit.</p>			

AVANT LA PREMIÈRE UTILISATION

 La fonction est activée.	 La fonction est activée. La cuisson s'arrête automatiquement.	 Le son alarme est désactivé.
Voyants du minuteur		
 Pour régler la fonction : Départ différé.	 Pour annuler le réglage.	



5. AVANT LA PREMIÈRE UTILISATION



AVERTISSEMENT!

Reportez-vous aux chapitres concernant la sécurité.

5.1 Nettoyage initial

		
Étape 1	Étape 2	Étape 3
Retirez tous les accessoires et les supports de grille amovibles de l'appareil.	Nettoyez l'appareil et les accessoires uniquement avec un chiffon en microfibre, de l'eau chaude et un détergent doux.	Placez les accessoires et les supports de grille amovibles dans l'appareil.

5.2 Première connexion

L'affichage indique un message de bienvenue après la première connexion.

Vous devez régler : Langue, Affichage Luminosité, Son touches, Volume alarme, Dureté de l'eau, Heure actuelle.

5.3 Préchauffage initial

Préchauffez le four à vide avant de l'utiliser pour la première fois.

Étape 1	Retirez du four les accessoires et les supports de grille amovibles.
Étape 2	Réglez la température maximale pour la fonction :  Laissez le four fonctionner pendant 1 heure.





AVANT LA PREMIÈRE UTILISATION

Étape 3	Réglez la température maximale pour la fonction :  Laissez le four fonctionner pendant 15 minutes.
<p>i Une odeur et de la fumée peuvent s'échapper du four durant le préchauffage. Assurez-vous que la pièce est ventilée.</p>	

5.4 Comment régler Dureté de l'eau



Lorsque vous branchez le four à une prise secteur, vous devez sélectionner le degré de dureté de l'eau.

Utilisez le papier réactif ou contactez votre fournisseur d'eau pour contrôler le niveau de dureté de l'eau.

			
Étape 1	Étape 2	Étape 3	Étape 4
Mettez le papier réactif dans l'eau pendant environ 1 seconde. Ne mettez pas le papier réactif sous l'eau du robinet.	Secouez le papier réactif pour éliminer l'excédent d'eau.	Après 1 minute, vérifiez la dureté de l'eau dans le tableau ci-dessous.	Définissez le degré de dureté de l'eau : Menu / Configurations / Configuration / Dureté de l'eau.
<p>i Les couleurs du papier réactif continuent de changer. Ne vérifiez pas la dureté de l'eau plus de 1 minute après le test.</p>			
<p>Vous pouvez changer le niveau de dureté de l'eau dans le menu : Configurations / Configuration / Dureté de l'eau.</p>			

Le tableau indique la plage de dureté de l'eau (dH) avec le niveau correspondant de dépôt calcaire et la classification de l'eau. Réglez le niveau de dureté de l'eau en fonction du tableau.

Dureté de l'eau		Papier réactif	Dépôt de calcium (mmol/l)	Dépôt calcaire (mg/l)	Classification de l'eau
Niveau	dH				
1	0 - 7	<div style="border: 1px solid black; width: 100px; height: 15px; margin-bottom: 2px;"></div> <div style="border: 1px solid black; width: 100px; height: 15px; background-color: black; margin-bottom: 2px;"></div>	0 - 1.3	0 - 50	douce
2	8 - 14	<div style="border: 1px solid black; width: 100px; height: 15px; margin-bottom: 2px;"></div> <div style="border: 1px solid black; width: 100px; height: 15px; background-color: black; margin-bottom: 2px;"></div> <div style="border: 1px solid black; width: 100px; height: 15px; background-color: black; margin-bottom: 2px;"></div>	1.4 - 2.5	51 - 100	modérément dure

Dureté de l'eau		Papier réactif	Dépôt de calcium (mmol/l)	Dépôt calcaire (mg/l)	Classification de l'eau
Niveau	dH				
3	15 - 21		2.6 - 3.8	101 - 150	dure
4	≥ 22		≥ 3,9	≥ 151	très dure

Si le niveau de dureté de l'eau du robinet est de 4, remplissez le bac à eau avec de l'eau plate en bouteille.

6. UTILISATION QUOTIDIENNE



AVERTISSEMENT!

Reportez-vous aux chapitres concernant la sécurité.

6.1 Comment régler Modes de cuisson

Étape 1	Allumez le four. Le mode de cuisson par défaut s'affiche.
Étape 2	Appuyez sur le symbole du mode de cuisson pour accéder au sous-menu.
Étape 3	Sélectionnez le mode de cuisson et appuyez sur : OK . L'écran affiche : température.
Étape 4	Réglage : température. Appuyez sur OK .
Étape 5	Appuyez sur START . Sonde de cuisson - vous pouvez brancher la sonde à tout moment avant ou pendant la cuisson.
STOP - appuyez pour désactiver le mode de cuisson.	
Étape 6	Mettez à l'arrêt le four.

6.2 Comment régler : Mode de cuisson Vapeur

Étape 1	Allumez le four. Sélectionnez et appuyez sur le symbole du mode de cuisson pour accéder au sous-menu.
Étape 2	Appuyez sur  . Réglez le mode de cuisson vapeur.

Étape 3	Appuyez sur : OK . Les réglages de la température s'affichent.
Étape 4	Réglez la température.
Étape 5	Appuyez sur OK .
Étape 6	Appuyez sur le couvercle du bac à eau pour l'ouvrir.
Étape 7	<p>Remplissez le bac à eau d'eau froide jusqu'au niveau maximal (environ 950 ml) jusqu'à ce que le signal sonore retentisse ou que le message s'affiche. Ne remplissez pas le bac à eau au-delà de sa capacité maximale. Il existe un risque de fuite d'eau, de débordement et de dégâts des meubles.</p> <div style="border: 1px solid black; padding: 5px;"> <p> AVERTISSEMENT! Utilisez uniquement de l'eau froide du robinet. N'utilisez pas d'eau filtrée (deminéralisée) ou distillée. N'utilisez pas d'autres liquides. Ne versez pas de liquides inflammables ni d'alcool dans le bac à eau.</p> </div>
Étape 8	Remplacez le bac à eau dans sa position initiale.
Étape 9	Appuyez sur START . De la vapeur apparaît après environ 2 minutes. Une fois la température définie atteinte, un signal sonore retentit.
Étape 10	Quand le bac à eau est presque vide, le signal sonore retentit. Remplissez le bac à eau.
Étape 11	Éteignez le four.
Étape 12	Videz le bac à eau à la fin de la cuisson. Reportez-vous au chapitre « Entretien et nettoyage », Vidange du réservoir.
Étape 13	L'eau résiduelle peut se condenser dans la cavité. Après la cuisson, ouvrez prudemment la porte du four. Lorsque le four a refroidi, séchez la cavité à l'aide d'un chiffon doux.

6.3 Comment régler : Cuisson assistée

Chaque plat apparaissant dans ce sous-menu a une fonction et une température recommandées. Vous pouvez régler le temps et la température.



Pour certains plats, vous pouvez également réaliser la cuisson avec :

- Poids automatique
- Sonde de cuisson

Le niveau de cuisson du plat :







- Saignant ou Moins
- À point



- Bien cuit ou Plus

Étape 1	Mettez en fonctionnement le four.
Étape 2	Appuyez sur  .
Étape 3	Appuyez sur  . Saisissez : Cuisson assistée.
Étape 4	Choisissez un plat ou un type d'aliment.
Étape 5	Appuyez sur START .







6.4 Modes de cuisson

FONCTIONS STANDARD

Mode de cuisson	Application
 Gril	Pour faire griller des aliments peu épais et du pain.
 Turbo gril	Pour rôti de gros morceaux de viande ou de volaille avec os sur un seul niveau. Pour gratiner et faire dorer.
 Chaleur tournante	Pour faire cuire sur 3 niveaux en même temps et pour sécher des aliments. Diminuez les températures de 20 à 40 °C par rapport à la Chauffage Haut/Bas.
 Plats Surgelés	Pour rendre croustillants vos plats préparés, tels que frites, pommes quartiers et nems.
 Chauffage Haut/Bas	Pour cuire et rôti des aliments sur un seul niveau.
 Fonction Pizza	Pour cuire des pizzas. Pour faire dorer de façon intensive et obtenir un dessous croustillant.



Mode de cuisson	Application
 <p>Chauffage inférieur</p>	Pour cuire des gâteaux avec dessous croustillant et pour stériliser des aliments.
 <p>Levée de pâte/pain</p>	Pour accélérer la levée de la pâte. Elle empêche la surface de la pâte de sécher et lui permet de garder toute son élasticité.

PROGRAMMES SPÉCIAUX

Mode de cuisson	Application
 <p>Stérilisation</p>	Pour faire des conserves de légumes (au vinaigre, etc.).
 <p>Déshydratation</p>	Pour déshydrater des fruits, des légumes et des champignons en tranches.
 <p>Chauffe-plats</p>	Pour préchauffer vos assiettes avant de les servir.
 <p>Décongélation</p>	Pour décongeler des aliments (fruits et légumes). Le temps de décongélation dépend de la quantité et de la grosseur des plats surgelés.
 <p>Gratiner</p>	Pour des plats tels que des lasagnes ou un gratin de pommes de terre. Pour gratiner et faire dorer.
 <p>Cuisson basse température</p>	Pour préparer des rôtis tendres et juteux.
 <p>Maintien au chaud</p>	Pour maintenir les aliments au chaud.

Mode de cuisson	Application
 <p>Chaleur Tournante Humide</p>	<p>Cette fonction est conçue pour économiser de l'énergie en cours de cuisson. Lorsque vous utilisez cette fonction, la température à l'intérieur de la cavité peut différer de la température sélectionnée. La chaleur résiduelle est utilisée. La puissance peut être réduite. Pour plus d'informations, consultez la partie sur les remarques du chapitre « Utilisation quotidienne ». Chaleur Tournante Humide.</p>

FONCTIONS VAPEUR

Mode de cuisson	Application
 <p>Réhydratation vapeur</p>	<p>Faire réchauffer des aliments à la vapeur évite que la surface ne se dessèche. La chaleur est diffusée de façon douce et homogène, ce qui permet de conserver les saveurs et arômes des aliments comme s'ils venaient d'être préparés. Vous pouvez utiliser cette fonction pour réchauffer directement des aliments sur une assiette. Vous pouvez réchauffer plusieurs assiettes en même temps sur différents niveaux de grille.</p>
 <p>Cuisson du pain</p>	<p>Utilisez cette fonction pour préparer de très bons pains et petits pains et obtenir un excellent résultat professionnel en matière de croustillant, de couleur et de brillance de la croûte.</p>
 <p>Humidité Faible</p>	<p>Cette fonction convient pour la viande, la volaille, les plats au four et les ragoûts. Grâce à sa combinaison de vapeur et de chaleur, la viande conserve une texture tendre et juteuse, ainsi qu'une surface croustillante.</p>

6.5 Remarques sur : Chaleur Tournante Humide

Cette fonction était utilisée pour se conformer à la classe d'efficacité énergétique et aux exigences Ecodesign (selon les normes EU 65/2014 et EU 66/2014). Tests conformes aux normes :

IEC/EN 60350-1

La porte du four doit être fermée pendant la cuisson pour que la fonction ne soit pas interrompue et que le four fonctionne avec la plus grande efficacité énergétique possible.

Lorsque vous utilisez cette fonction, l'éclairage s'éteint automatiquement au bout de 30 secondes.

Pour consulter les instructions de cuisson, reportez-vous au chapitre « Conseils », Chaleur Tournante Humide. Pour obtenir des recommandations générales sur l'économie d'énergie, reportez-vous au chapitre « Efficacité énergétique », « Économie d'énergie ».

7. FONCTIONS DE L'HORLOGE

7.1 Description des fonctions de l'horloge

Fonctions de l'horloge	Application
Heure de cuisson	Pour définir la durée de la cuisson. Le maximum est de 23 h 59 min.
Fin de l'action	Pour programmer l'action à la fin du décompte du minuteur.
Départ différé	Pour reporter le début et / ou la fin de la cuisson.
Prolongation de la durée	Pour prolonger le temps de cuisson.
Rappel	Pour régler un décompte. Le maximum est de 23 h 59 min. Cette fonction n'a aucun effet sur le fonctionnement de l'appareil.
Compteur	Surveille la durée de fonctionnement de la fonction. Compteur - vous pouvez l'activer et la désactiver.

7.2 Comment régler Fonctions de l'horloge

Comment régler l'horloge	
Étape 1	Appuyez sur : Heure actuelle.
Étape 2	Réglez l'heure. Appuyez sur : OK.

Comment régler le temps de cuisson	
Étape 1	Choisissez le mode de cuisson et réglez la température.
Étape 2	Appuyez sur  .
Étape 3	Réglez l'heure. Appuyez sur : OK.

Comment choisir une option de fin	
Étape 1	Choisissez le mode de cuisson et réglez la température.

FONCTIONS DE L'HORLOGE

Comment choisir une option de fin	
Étape 2	Appuyez sur  .
Étape 3	Réglez le temps de cuisson.
Étape 4	Appuyez sur : ● ● ● .
Étape 5	Appuyez sur : Fin de l'action.
Étape 6	Choisissez la valeur souhaitée : Fin de l'action.
Étape 7	Appuyez sur : OK. Répétez l'action jusqu'à ce que l'écran principal soit affiché.

Comment différer le début de la cuisson	
Étape 1	Réglez le mode de cuisson et la température.
Étape 2	Appuyez sur  .
Étape 3	Réglez le temps de cuisson.
Étape 4	Appuyez sur : ● ● ● .
Étape 5	Appuyez sur : Départ différé.
Étape 6	Choisissez la valeur.
Étape 7	Appuyez sur : OK. Répétez l'action jusqu'à ce que l'écran principal soit affiché.

Comment prolonger le temps de cuisson	
S'il ne reste que 10 % du temps de cuisson et que les aliments ne semblent toujours pas cuits, vous pouvez prolonger le temps de cuisson. Vous pouvez également modifier le mode de cuisson.	
Appuyez sur +1min pour prolonger le temps de cuisson.	

Comment modifier les réglages du minuteur

Étape 1 Appuyez sur : .

Étape 2 Réglez la valeur du minuteur.

Étape 3 Appuyez sur : .

Vous pouvez modifier la durée à tout moment en cours de cuisson.

8. UTILISATION DES ACCESSOIRES



AVERTISSEMENT!

Reportez-vous aux chapitres concernant la sécurité.

8.1 Insertion des accessoires

Une petite indentation sur le dessus apporte plus de sécurité. Les indentations sont également des dispositifs anti-bascule. Le rebord élevé de la grille empêche les ustensiles de cuisine de glisser sur la grille.

Grille métallique:

Poussez la grille entre les barres de guidage des supports de grille.

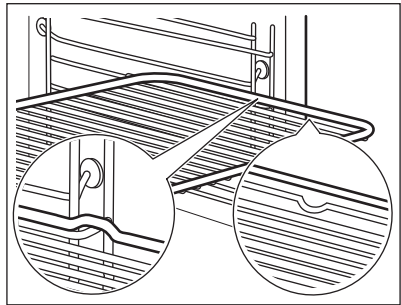

Plateau de cuisson / Plat à rôtir:

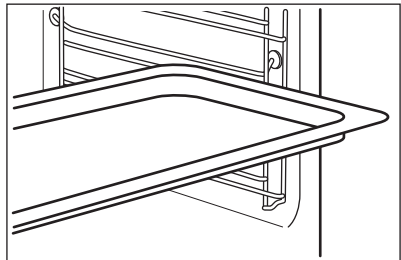

Poussez la plaque entre les rails du support de grille.



UTILISATION DES ACCESSOIRES

8.2 Sonde de cuisson

Sonde de cuisson - mesure la température à l'intérieur des aliments. Vous pouvez l'utiliser avec tous les modes de cuisson.



Il y a deux températures à régler :	
 Température du four : 120 °C minimum.	 La température au cœur.

Pour obtenir les meilleurs résultats de cuisson :		
Les ingrédients doivent être à température ambiante.	Ne l'utilisez pas pour des plats liquides.	Pendant la cuisson, l'aliment doit rester dans le plat.

Le four calcule la durée jusqu'à la fin de cuisson approximative. Elle dépend de la quantité d'aliments, de la fonction du four et de la température sélectionnées.

8.3 Comment utiliser : Sonde de cuisson

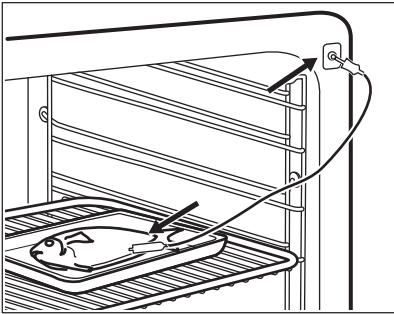
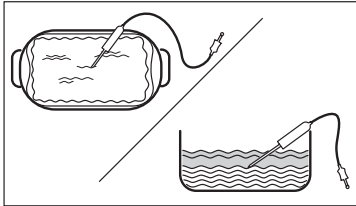
Étape 1	Mettez en fonctionnement le four.
Étape 2	Réglez le mode de cuisson et, si nécessaire, la température du four.
Étape 3	Insérez : Sonde de cuisson.
Viande, volaille et poisson	Ragoût
Insérer la pointe de Sonde de cuisson au centre de la viande ou du poisson, si possible dans la partie la plus épaisse. Assurez-vous qu'au moins 3/4 de Sonde de cuisson est à l'intérieur du plat.	Insérer la pointe de Sonde de cuisson exactement au centre de la cocotte. Sonde de cuisson doit être maintenue en un seul endroit pendant la cuisson. Pour y parvenir, utilisez un ingrédient solide. Utilisez le rebord du plat de cuisson pour appuyer la poignée en silicone de Sonde de cuisson. La pointe de Sonde de cuisson ne doit pas toucher le fond d'un plat de cuisson.

	
Étape 4	<p>Branchez Sonde de cuisson dans la prise à l'avant du four. L'affichage indique la température actuelle de : Sonde de cuisson.</p>
Étape 5	<p> - appuyez pour régler la température à cœur du capteur.</p>
Étape 6	<p>● ● ● - appuyez pour définir l'option préférée :</p> <ul style="list-style-type: none"> • Son alarme - lorsque les aliments atteignent la température à cœur, le signal sonore retentit. • Son et arrêt du four - lorsque les aliments atteignent la température à cœur, le signal sonore retentit et le four s'arrête.
Étape 7	<p>Sélectionnez l'option et appuyez à plusieurs reprises sur : OK pour accéder à l'écran principal.</p>
Étape 8	<p>Appuyez sur START . Lorsque les aliments atteignent la température définie, un signal sonore retentit. Vous pouvez choisir d'arrêter ou de poursuivre la cuisson pour vous assurer que l'aliment est bien cuit.</p>
Étape 9	<p>Retirez Sonde de cuisson la fiche de la prise et retirez le plat du four.</p> <div style="border: 1px solid black; padding: 5px; margin-top: 10px;"> <p> AVERTISSEMENT! Il y a un risque de brûlure car Sonde de cuisson devient chaud. Faites attention en la débranchant et en la retirant de l'aliment.</p> </div>

9. FONCTIONS SUPPLÉMENTAIRES

9.1 Comment enregistrer : Mes programmes

Vous pouvez sauvegarder vos réglages favoris, tels que le mode de cuisson, le temps de cuisson, la température ou la fonction de nettoyage. Vous pouvez sauvegarder 3 réglages favoris.

FONCTIONS SUPPLÉMENTAIRES

Étape 1	Allumez l'appareil.
Étape 2	Sélectionnez le réglage préféré.
Étape 3	Appuyez sur :  . Sélectionnez : Mes programmes.
Étape 4	Sélectionnez : Enregistrer les réglages actuels.
Étape 5	Appuyez sur + pour ajouter le réglage à la liste de : Mes programmes. Appuyez sur OK.
↶ - appuyez pour réinitialiser le réglage. ⊗ - appuyez pour annuler le réglage.	



9.2 Verrouillage des touches

Cette fonction permet d'éviter une modification involontaire du mode de cuisson.

Étape 1	Allumez l'appareil.
Étape 2	Sélectionnez un mode de cuisson.
Étape 3	☆, 🔒 - appuyez simultanément pour activer la fonction.
Pour désactiver la fonction, répétez l'étape 3.	

9.3 Arrêt automatique

Pour des raisons de sécurité, l'appareil s'éteint au bout d'un certain temps si un mode de cuisson est en cours et vous ne modifiez aucun réglage.

 (°C)	 (h)
30 - 115	12.5
120 - 195	8.5
200 - 245	5.5
250 - maximum	3

L'arrêt automatique ne fonctionne pas avec les fonctions : Eclairage four, Sonde de cuisson, Fin de cuisson, Cuisson basse température.

9.4 Ventilateur de refroidissement

Lorsque l'appareil fonctionne, le ventilateur de refroidissement se met automatiquement en marche pour refroidir les surfaces de l'appareil. Si vous éteignez l'appareil, le ventilateur de refroidissement peut continuer à fonctionner jusqu'à ce que l'appareil refroidisse.

10. CONSEILS





10.1 Recommandations de cuisson







Les températures et temps de cuisson se trouvant dans les tableaux ne sont indiqués qu'à titre indicatif. Ils varient selon les recettes, la qualité et la quantité des ingrédients utilisés. Votre appareil peut cuire ou rôtir les aliments différemment de l'appareil que vous aviez auparavant. Les conseils ci-dessous contiennent les réglages de température, les temps de cuisson et les positions de grilles recommandés pour des types de plats en particulier. Si vous ne trouvez pas les réglages appropriés pour une recette spécifique, cherchez-en une qui s'en rapproche. Pour plus de recommandations de cuisson, consultez les tableaux de cuisson sur notre site Internet. Pour trouver les conseils de cuisson, vérifiez le code produit (numéro PNC) sur la plaque signalétique qui se trouve sur le cadre avant de la cavité de l'appareil.

10.2 Chaleur Tournante Humide

Pour de meilleurs résultats, suivez les suggestions indiquées dans le tableau ci-dessous.



		 (°C)		 (min)
Petits pains su-crés, 16 pièces	Plateau de cuisson ou plat à rôtir	180	2	25 - 35
Gâteau Roulé	Plateau de cuisson ou plat à rôtir	180	2	15 - 25
Poisson entier, 0.2 kg	Plateau de cuisson ou plat à rôtir	180	3	15 - 25
Cookies, 16 pièces	Plateau de cuisson ou plat à rôtir	180	2	20 - 30
Meringues, 24 pièces	Plateau de cuisson ou plat à rôtir	160	2	25 - 35

CONSEILS

		 (°C)		 (min)
Muffins, 12 pièces	Plateau de cuisson ou plat à rôtir	180	2	20 - 30
Petite pâtisserie salée, 20 pièces	Plateau de cuisson ou plat à rôtir	180	2	20 - 30
Biscuits à pâte sablée, 20 pièces	Plateau de cuisson ou plat à rôtir	140	2	15 - 25
Tartelettes, 8 pièces	Plateau de cuisson ou plat à rôtir	180	2	15 - 25

10.3 Chaleur Tournante Humide - accessoires recommandés

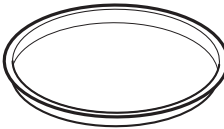
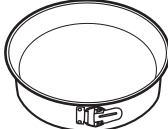
Utilisez les moules et récipients foncés et non réfléchissants. Ils offrent une meilleure absorption de la chaleur que les plats réfléchissants de couleur claire.

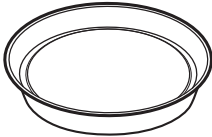



			
Plaque à pizza	Plat de cuisson	Ramequins	Moule pour fond de tarte
Sombre, non réfléchissant Diamètre de 28 cm	Sombre, non réfléchissant Diamètre : 26 cm	Céramique 8 cm de diamètre, 5 cm de hauteur	Sombre, non réfléchissant Diamètre de 28 cm

10.4 Tableaux de cuisson pour les instituts de tests





Informations pour les organismes de contrôle

Tests conformes aux normes : EN 60350, IEC 60350.





Cuisson sur un niveau - cuisson en moule

		 °C	 min	
Génoise allégée	Chaleur tournante	160	45 - 60	2
Génoise allégée	Chauffage Haut/Bas	160	45 - 60	2
Tarte aux pommes, 2 moules Ø20 cm	Chaleur tournante	160	55 - 65	2
Tarte aux pommes, 2 moules Ø20 cm	Chauffage Haut/Bas	180	55 - 65	1
Sablé	Chaleur tournante	140	25 - 35	2
Sablé	Chauffage Haut/Bas	140	25 - 35	2





Cuisson sur un niveau - biscuits
Utilisez le troisième niveau de la grille.

		 °C	 min
Petits gâteaux, 20 par plateau, préchauffer le four à vide	Chaleur tournante	150	20 - 30
Petits gâteaux, 20 par plateau, préchauffer le four à vide	Chauffage Haut/Bas	170	20 - 30

Cuisson sur plusieurs niveaux - biscuits





		 °C	 min	
Sablé	Chaleur tournante	140	25 - 45	2 / 4
Petits gâteaux, 20 par plateau, préchauffer le four à vide	Chaleur tournante	150	25 - 35	1 / 4

ENTRETIEN ET NETTOYAGE

		 °C	 min	
Génoise allégée	Chaleur tournante	160	45 - 55	2 / 4
Tarte aux pommes, 1 pain moulé par grille (Ø 20 cm)	Chaleur tournante	160	55 - 65	2 / 4

Gril

Préchauffez le four vide pendant 5 minutes.
Réglez le gril à la température maximale.

		 min	
Pain grillé	Gril	1 - 2	5
Steak de bœuf, tourner à mi- cuisson	Gril	24 - 30	4

11. ENTRETIEN ET NETTOYAGE



AVERTISSEMENT!

Reportez-vous aux chapitres concernant la sécurité.

11.1 Remarques concernant le nettoyage

 Agent nettoy- ant	Nettoyez l'avant de l'appareil uniquement avec un chiffon en microfibre imbibé d'eau tiède et d'un détergent doux.
	Utilisez une solution de nettoyage pour nettoyer les surfaces métalliques.
	Nettoyez les taches avec un détergent doux.



Utilisation quotidienne

Nettoyez la cavité après chaque utilisation. L'accumulation de graisse ou d'autres résidus peut provoquer un incendie.

Ne conservez pas les aliments dans l'appareil pendant plus de 20 minutes. Séchez la cavité uniquement avec un chiffon en microfibre après chaque utilisation.



Accessoires

Nettoyez tous les accessoires après chaque utilisation et laissez-les sécher. Utilisez uniquement un chiffon en microfibre avec de l'eau tiède et un détergent doux. Ne lavez pas les accessoires au lave-vaisselle.

Ne nettoyez pas les accessoires anti-adhésifs avec un produit nettoyant abrasif ou des objets tranchants.

11.2 Comment retirer : Supports de grille

Retirez les supports de grille pour nettoyer le four.

Étape 1	Éteignez le four et attendez qu'il soit froid.	
Étape 2	Tirez avec précaution les supports de grille vers le haut et sortez-les de la prise avant.	
Étape 3	Écartez l'avant du support de grille de la paroi latérale.	
Étape 4	Sortez les supports de la prise arrière.	
Installez les supports de grille dans l'ordre inverse.		

11.3 Comment utiliser : Nettoyage par pyrolyse

Nettoyez le four avec Nettoyage par pyrolyse.



AVERTISSEMENT!
Risque de brûlure.





ATTENTION!
Si un autre appareil est installé dans le même meuble, ne l'utilisez pas en même temps que cette fonction. Vous risqueriez d'endommager le four.

ENTRETIEN ET NETTOYAGE

Avant le Nettoyage par pyrolyse :

Éteignez le four et attendez qu'il soit froid.	Retirez les accessoires.	Nettoyez la sole du four et la vitre interne de la porte avec de l'eau tiède, un chiffon doux et un détergent doux.
------------------------------------------------	--------------------------	---------------------------------------------------------------------------------------------------------------------

Ne remplissez pas le réservoir d'eau pendant le nettoyage. Cela relance le cycle de nettoyage.

Étape 1	Mettez en fonctionnement le four.
Étape 2	Appuyez sur :  / Nettoyage.
Étape 3	Placez le plateau de cuisson sur le premier niveau pour récupérer l'eau du réservoir. OK - appuyez pour lancer la vidange du réservoir d'eau.
Étape 4	Lorsque la vidange du réservoir est terminée, retirez le plateau de cuisson et les supports de grille amovibles. Essuyez la cavité du four et la vitre interne de la porte avec un chiffon doux. Appuyez sur :  .
Étape 5	Sélectionnez le mode de nettoyage.

Option	Mode de nettoyage	Durée
Nettoyage par pyrolyse, rapide	Nettoyage léger	1 h
Nettoyage par pyrolyse, normale	Nettoyage normal	1 h 30 min
Nettoyage par pyrolyse, renforcée	Nettoyage complet	3 h

 Lorsque le nettoyage commence, l'éclairage est éteint et le ventilateur de refroidissement fonctionne à une vitesse plus élevée.

STOP - appuyez pour interrompre le nettoyage avant qu'il ne soit terminé.
N'utilisez pas le four avant que le symbole de verrouillage de la porte ait disparu.

Une fois le nettoyage terminé :

Éteignez le four et attendez qu'il soit froid.	Nettoyez la cavité avec un chiffon doux.	Retirez les résidus du fond de la cavité.
------------------------------------------------	------------------------------------------	-------------------------------------------

11.4 Nettoyage conseillé

Lorsque le rappel apparaît, un nettoyage est recommandé.

Utilisez la fonction : Nettoyage par pyrolyse.

11.5 Comment utiliser : Détartrage

Avant de commencer :

Éteignez le four et attendez qu'il soit froid.	Retirez les accessoires.	Vérifiez que le bac à eau est vide.
------------------------------------------------	--------------------------	-------------------------------------

Durée de la première partie : environ 100 minutes

Étape 1	Placez le plat à rôtir sur le premier niveau.
Étape 2	Versez 250 ml d'agent détartrant dans le bac à eau.
Étape 3	Remplissez le bac à eau d'eau jusqu'à atteindre le niveau maximal, qu'un signal sonore retentisse ou qu'un message s'affiche.
Étape 4	Sélectionnez : Menu / . Nettoyage
Étape 5	Activez la fonction et suivez les instructions à l'affichage. La première partie du détartrage commence.
Étape 6	Une fois la première partie terminée, videz le plat à rôtir et réinstallez-le sur le premier niveau.

Durée de la deuxième partie : environ 35 minutes

Étape 7	Remplissez le bac à eau d'eau jusqu'à atteindre le niveau maximal, qu'un signal sonore retentisse ou qu'un message s'affiche.
Étape 8	Une fois la fonction terminée, retirez le plat à rôtir.

 Lorsque cette fonction est en cours, l'éclairage est éteint.

Une fois le détartrage terminé :

Éteignez le four.	Lorsque le four a refroidi, séchez la cavité à l'aide d'un chiffon doux.	Laissez la porte du four ouverte et attendez que la cavité soit sèche.
 Si des résidus de calcaire restent dans le four après le détartrage, l'affichage vous invite à répéter la procédure.		

11.6 Rappel de détartrage

Deux rappels vous invitent à détartrer le four. Vous ne pouvez pas désactiver le rappel du détartrage.

Type	Description
Premier rappel	Vous recommande de détartrer le four.
Deuxième rappel	Vous oblige à détartrer le four. Si vous ne détartriez pas le four quand le rappel fort est allumé, les fonctions vapeur sont désactivées.

11.7 Comment utiliser : Rinçage

Avant de commencer :

Éteignez le four et attendez qu'il soit froid.	Retirez les accessoires.
------------------------------------------------	--------------------------

Étape 1	Placez le plat à rôtir sur le premier niveau.
Étape 2	Remplissez le bac à eau avec de l'eau au niveau maximal jusqu'à ce qu'un signal sonore retentisse ou qu'un message s'affiche.
Étape 3	Sélectionnez : Menu / . Nettoyage Rinçage. Durée : environ 30 minutes
Étape 4	Activez la fonction et suivez les instructions à l'affichage.
Étape 5	Une fois la fonction terminée, retirez le plat à rôtir.
 Lorsque cette fonction est en cours, l'éclairage est éteint.	

11.8 Comment utiliser : Vidange du réservoir

Utilisez cette fonction après une cuisson avec un mode de cuisson vapeur pour retirer l'eau résiduelle du bac à eau.

Avant de commencer :	
Éteignez le four et attendez qu'il soit froid.	Retirez les accessoires.
Étape 1	Placez le plat à rôtir sur le premier niveau.
Étape 2	Sélectionnez : Menu / Nettoyage / Vidange du réservoir. Durée : 6 min
Étape 3	Activez la fonction et suivez les instructions à l'affichage.
Étape 4	Une fois la fonction terminée, retirez le plat à rôtir.
<p> Lorsque cette fonction est en cours, l'éclairage est éteint.</p>	

11.9 Comment démonter et installer : Porte

Vous pouvez retirer la porte ainsi que les panneaux de verre intérieurs pour les nettoyer. Le nombre de vitres diffère selon les modèles.



AVERTISSEMENT!

La porte est lourde.



ATTENTION!

Manipulez soigneusement la vitre, en particulier autour des bords du panneau avant. Le verre peut se briser.

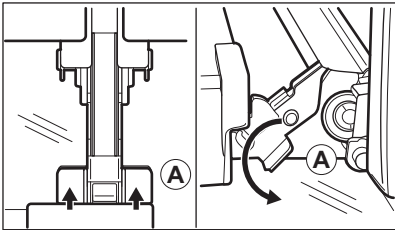
Étape 1	Ouvrez entièrement la porte.	
Étape 2	Soulevez et appuyez sur les leviers de blocage (A) sur les deux charnières de la porte.	
Étape 3	Fermez la porte du four à la première position (à un angle d'environ 70°). Tenez la porte des deux côtés et retirez-la du four en la soulevant. Posez la porte, face extérieure vers le bas, sur un linge doux posé sur une surface stable.	

ENTRETIEN ET NETTOYAGE

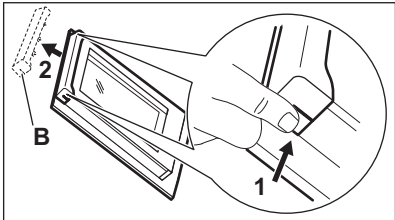
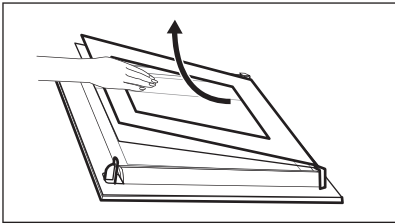
<p>Étape 4</p>	<p>Tenez la garniture de porte (B) sur le bord supérieur de la porte des deux côtés et poussez vers l'intérieur pour libérer le joint du clip.</p>	
<p>Étape 5</p>	<p>Retirez le cache de la porte en le tirant vers l'avant.</p>	
<p>Étape 6</p>	<p>Saisissez les panneaux de verre de la porte par leur bord supérieur un par un et dégagez-les du guide.</p>	
<p>Étape 7</p>	<p>Nettoyez la vitre à l'eau savonneuse. Essuyez soigneusement la vitre. Ne passez pas les panneaux en verre au lave-vaisselle.</p>	
<p>Étape 8</p>	<p>Après le nettoyage, effectuez les étapes ci-dessus dans le sens inverse.</p>	
<p>Étape 9</p>	<p>Installez d'abord le plus petit des panneaux, puis le plus grand, et terminez par la porte.</p>	

11.10 Comment remplacer : Éclairage



AVERTISSEMENT!

Risque d'électrocution.
L'éclairage peut être chaud.

Avant de remplacer l'éclairage :

Étape 1	Étape 2	Étape 3
<p>Éteignez le four. Attendez que le four ait refroidi.</p>	<p>Débranchez le four de l'alimentation secteur.</p>	<p>Placez un chiffon au fond de la cavité.</p>

Lampe supérieure

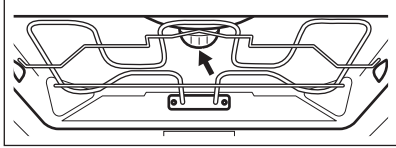
Étape 1	Tournez le diffuseur en verre pour le retirer.	
Étape 2	Retirez l'anneau métallique et nettoyez le couvercle en verre.	
Étape 3	Remplacez l'ampoule par une ampoule adéquate résistant à une température de 300 °C.	
Étape 4	Fixez l'anneau en métal sur le diffuseur en verre et installez-le.	

Lampe latérale

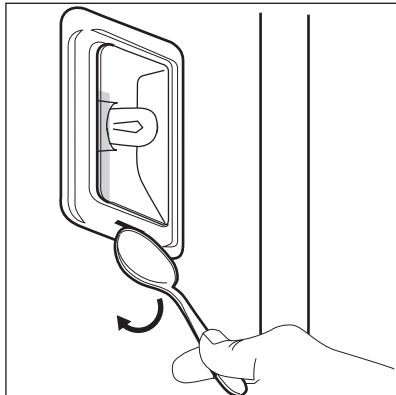
Étape 1	Retirez le support d'étagère gauche pour accéder à l'éclairage.	
Étape 2	Utilisez un objet étroit, émoussé (par ex. une cuillère à café) pour retirer le couvercle en verre.	
Étape 3	Nettoyez le diffuseur en verre.	
Étape 4	Remplacez l'ampoule par une ampoule adéquate résistant à une température de 300 °C.	
Étape 5	Installez le diffuseur en verre.	
Étape 6	Installez le support d'étagère gauche.	



12. DÉPANNAGE





AVERTISSEMENT!

Reportez-vous aux chapitres concernant la sécurité.

12.1 Que faire si...



 L'appareil ne s'allume pas ou ne chauffe pas	
 Cause probable	 Solution
L'appareil n'est pas branché à une source d'alimentation électrique ou le branchement est incorrect.	Vérifiez que l'appareil est correctement branché à une source d'alimentation électrique.
L'horloge n'est pas réglée.	Réglez l'horloge, pour plus de détails, reportez-vous au Fonctions de l'horloge chapitre, Comment régler : Fonctions de l'horloge.
La porte n'est pas correctement fermée.	Fermez complètement la porte.
Le fusible a disjoncté.	Vérifiez que le fusible est bien la cause de l'anomalie. Si le problème se reproduit, faites appel à un électricien qualifié.
L'appareil Sécurité enfants s'allume.	Consultez le chapitre « Menu », Sous-menu : Options.

 Composants	
 Description	 Solution
L'ampoule est grillée.	Remplacez l'ampoule, pour avoir des détails consultez le chapitre « Entretien et nettoyage », Comment remplacer : Éclairage.

Une coupure de courant arrête toujours la procédure de nettoyage. Répétez le nettoyage s'il est interrompu par une coupure de courant.

12.2 Comment gérer : Codes d'erreur

Quand une erreur de logiciel se produit, l'affichage indique un message d'erreur. Cette section présente la liste des problèmes que vous pouvez gérer seul.

 Code et description	 Solution
C2 - la Sonde de cuisson est dans la cavité de l'appareil pendant le Nettoyage par pyrolyse.	Sortez la Sonde de cuisson.
C3 - la porte n'est pas correctement fermée pendant Nettoyage par pyrolyse.	Refermez la porte.
F111 - Sonde de cuisson n'est pas correctement insérée dans la prise.	Bien brancher Sonde de cuisson dans la prise.
F240, F439 - les champs tactiles de l'affichage ne fonctionnent pas correctement.	Nettoyez la surface de l'affichage. Vérifiez que les champs tactiles sont propres.
F908 - le système de l'appareil ne peut pas se connecter au bandeau de commande.	Éteignez puis rallumez l'appareil.

12.3 Données de maintenance

Si vous ne trouvez pas de solution au problème, veuillez contacter votre revendeur ou un service après-vente agréé.

Les informations nécessaires au service après-vente figurent sur la plaque signalétique. La plaque signalétique se trouve sur le cadre avant de la cavité de l'appareil. Ne retirez pas la plaque signalétique de la cavité de l'appareil.

Nous vous recommandons d'écrire les informations ici :	
Modèle (Mod.)
Référence produit (PNC)
Numéro de série (SN)

13. RENDEMENT ÉNERGÉTIQUE

13.1 Informations produits et fiche d'informations produits

Nom du fournisseur	AEG
Identification du modèle	BSE77280M 944188685 BSE77228BM 944188655 BSK772280M 944188643 BSS772280B 944188644

RENDEMENT ÉNERGÉTIQUE

Indice d'efficacité énergétique	61.2	
Classe d'efficacité énergétique	A++	
Consommation d'énergie avec charge standard, en mode conventionnel	1.09 kWh/cycle	
Consommation d'énergie avec charge standard, en mode chaleur tournante	0.52 kWh/cycle	
Nombre de cavités	1	
Source de chaleur	Électricité	
Volume	71 l	
Type de four	Four encastrable	
Masse	BSE772280M	36.0 kg
	BSE77228BM	36.0 kg
	BSK772280M	36.0 kg
	BSS772280B	36.0 kg

IEC/EN 60350-1 - Appareils de cuisson domestiques électriques - Partie 1 : Cuisinières, fours, fours à vapeur et grils : Méthodes de mesure des performances.

13.2 Économie d'énergie



Cet appareil est doté de caractéristiques qui vous permettent d'économiser de l'énergie lors de votre cuisine au quotidien.

Assurez-vous que la porte de l'appareil est fermée lorsque l'appareil est en fonctionnement. Évitez d'ouvrir l'appareil trop souvent pendant la cuisson. Nettoyez régulièrement le joint de porte et assurez-vous qu'il est bien en place.

Utilisez des plats en métal pour accroître les économies d'énergie.

Dans la mesure du possible, ne préchauffez pas l'appareil avant la cuisson.

Lorsque vous préparez plusieurs plats à la fois, faites en sorte que les pauses entre les cuissons soient aussi courtes que possible.

Cuisson avec ventilation

Si possible, utilisez les fonctions de cuisson avec la ventilation pour économiser de l'énergie.

Chaleur résiduelle

Si un programme avec Durée est activé et que le temps de cuisson est supérieur à 30 minutes, les éléments chauffants s'éteignent automatiquement plus tôt dans certaines fonctions de l'appareil.

L'éclairage et le ventilateur continuent de fonctionner. Lorsque vous mettez à l'arrêt l'appareil, l'affichage montre la chaleur résiduelle. Vous pouvez utiliser cette chaleur pour le maintien au chaud des aliments.

Si la cuisson doit durer plus de 30 minutes, réduisez la température de l'appareil au minimum 3 à 10 minutes avant la fin de la cuisson. La chaleur résiduelle à l'intérieur de l'appareil poursuivra la cuisson.

Utilisez la chaleur résiduelle pour réchauffer d'autres plats.

Maintien des aliments au chaud

Sélectionnez la température la plus basse possible pour utiliser la chaleur résiduelle et maintenir le repas au chaud. La température ou le voyant de chaleur résiduelle s'affichent.

Cuisson avec l'éclairage éteint

Éteignez l'éclairage en cours de cuisson. Ne l'allumez que lorsque vous en avez besoin.

Chaleur Tournante Humide

Fonction conçue pour économiser de l'énergie en cours de cuisson.

Lorsque vous utilisez cette fonction, l'éclairage s'éteint automatiquement au bout de 30 secondes. Vous pouvez rallumer l'éclairage, mais cela réduira les économies d'énergie.

14. STRUCTURE DES MENUS

14.1 Menu

Élément du menu		Application
Cuisson assistée		Indique les programmes automatiques.
Nettoyage		Indique les programmes de nettoyage.
Mes programmes		Indique les réglages favoris.
Options		Pour régler l'appareil.
Configurations	Configuration	Pour régler l'appareil.
	Service	Affiche la version et la configuration du logiciel.

14.2 Sous-menu pour : Nettoyage

Sous-menu	Application
Vidange du réservoir	Procédure pour éliminer l'eau résiduelle du bac à eau après avoir utilisé les fonctions de vapeur.
Nettoyage par pyrolyse, rapide	Durée : 1 h.
Nettoyage par pyrolyse, normale	Durée : 1 h 30 min.

STRUCTURE DES MENUS

Sous-menu	Application
Nettoyage par pyrolyse, renforcée	Durée : 3 h.
Détartrage	Procédure de nettoyage du tartre dans le circuit du générateur de vapeur.
Rinçage	La procédure de rinçage et de nettoyage du circuit du générateur de vapeur après une utilisation fréquente des fonctions vapeur.

14.3 Sous-menu pour : Options

Sous-menu	Application
Eclairage four	Allume et éteint l'éclairage.
Sécurité enfants	Empêche l'activation accidentelle de l'appareil. Lorsque l'option est activée, le texte Sécurité enfants s'affiche lorsque vous mettez en fonctionnement l'appareil. Pour permettre l'utilisation de l'appareil, choisissez les lettres du code dans l'ordre alphabétique. Lorsque l'option est activée, et l'appareil est éteint, la porte de l'appareil est verrouillée. L'accès au minuteur, à la télécommande et à l'éclairage est possible avec l'option activée.
Préchauffage rapide	Réduit la durée de préchauffage. L'option n'est disponible que pour certaines fonctions de l'appareil.
Indication Du Temps	Allume et éteint l'horloge.
Affichage Heure	Change le format de l'affichage de l'heure.

14.4 Sous-menu pour : Configuration

Sous-menu	Description
Langue	Définit la langue de l'appareil.
Affichage Luminosité	Règle la luminosité de l'affichage.

Sous-menu	Description
Son touches	Active et désactive la tonalité des champs tactiles. Il n'est pas possible de couper la tonalité pour : ①.
Volume alarme	Règle le volume des signaux sonores et des tonalités des touches.
Dureté de l'eau	Définit la dureté de l'eau.
Heure actuelle	Règle l'heure et la date actuelles.

14.5 Sous-menu pour : Service

Sous-menu	Description
Mode démo	Code d'activation / de désactivation : 2468
Version du logiciel	Informations sur la version logicielle.
Réinitialiser tous les réglages	Restaure les réglages d'usine.

15. C'EST SIMPLE !

Avant la première utilisation, vous devez régler :

Langue	Affichage Luminosité	Son touches	Volume alarme	Dureté de l'eau	Heure actuelle
--------	----------------------	-------------	---------------	-----------------	----------------

Pour commencer à utiliser l'appareil

Démarrage rapide	Mettez en marche l'appareil et commencez la cuisson avec la durée de la fonction et la température par défaut.	Étape 1	Étape 2	Étape 3
		Maintenez la touche ①.	 ... - sélectionnez la fonction préférée.	Appuyez sur : START .

C'EST SIMPLE !

Pour commencer à utiliser l'appareil



Arrêt rapide	Éteindre l'appareil à tout moment, quel que soit l'affichage ou le message.	① - appuyer et maintenir enfoncé jusqu'à ce que l'appareil s'éteigne.
---------------------	-----------------------------------------------------------------------------	-----------------------------------------------------------------------

Pour lancer la cuisson

Étape 1	Étape 2	Étape 3	Étape 4	Étape 5
① - appuyer pour allumer l'appareil.	 ... - sélectionnez le mode de cuisson.	°C - réglez la température.	OK - appuyez pour confirmer.	START - appuyez pour démarrer la cuisson.

Apprenez à cuisiner plus vite



Utilisez les programmes automatiques pour préparer un plat rapidement avec les réglages par défaut :

Cuisson assistée	Étape 1	Étape 2	Étape 3	Étape 4
	Appuyez sur : ①.	Appuyez sur : 	Appuyez sur :  Cuisson assistée.	Choisissez le plat.

Utiliser les fonctions rapides pour régler le temps de cuisson

Assist. Fin 10 % Utilisez la fonction Assist. Fin 10 % pour prolonger la cuisson lorsqu'il ne reste que 10 % du temps de cuisson.	Pour prolonger le temps de cuisson, appuyez sur +1min.
---------------------------------------------------------------------------------------------------------------------------------------------	---------------------------------------------------------------

16. EN MATIÈRE DE PROTECTION DE L'ENVIRONNEMENT

Recyclez les matériaux portant le symbole . Déposez les emballages dans les conteneurs prévus à cet effet. Contribuez à la protection de l'environnement et à votre sécurité, recyclez vos produits électriques et électroniques. Ne jetez pas les appareils portant le symbole  avec les ordures ménagères. Emmenez un tel produit dans votre centre local de recyclage ou contactez vos services municipaux.

FR Concerne la France uniquement :



FR

Cet appareil,
ses accessoires
et cordons
se recyclent

REPRISE
À LA LIVRAISON



OU

À DÉPOSER
EN MAGASIN



OU

À DÉPOSER
EN DÉCHÈTERIE



FR



Points de collecte sur www.quefairedemesdechets.fr
Privilégiez la réparation ou le don de votre appareil !

FÜR PERFEKTE ERGEBNISSE

Danke, dass Sie sich für dieses AEG Produkt entschieden haben. Wir haben es geschaffen, damit Sie viele Jahre von seiner ausgezeichneten Leistung und den innovativen Technologien, die Ihnen das Leben erleichtern, profitieren können. Es ist mit Funktionen ausgestattet, die in gewöhnlichen Geräten nicht vorhanden sind. Bitte nehmen Sie sich ein paar Minuten Zeit, um das Beste aus ihm herauszuholen.

Besuchen Sie uns auf unserer Website, um:



Anwendungshinweise, Prospekte, Informationen zu Fehlerbehebung, Service und Reparatur zu erhalten:

www.aeg.com/support



Registrieren Sie Ihr Produkt, um einen erstklassigen Service zu erhalten:

www.registreaeg.com



Um Zubehör, Verbrauchsmaterial und Original-Ersatzteile für Ihr Gerät zu kaufen:

www.aeg.com/shop

KUNDENDIENST UND SERVICE

Verwenden Sie immer Original-Ersatzteile.

Halten Sie folgende Angaben bereit, wenn Sie sich an einen autorisierten Kundendienst wenden: Modell, PNC, Seriennummer.

Die Daten finden Sie auf dem Typenschild.

 Warnungs-/Sicherheitshinweise

 Allgemeine Informationen und Empfehlungen

 Informationen zum Umweltschutz

Änderungen vorbehalten.

INHALTSVERZEICHNIS

1. SICHERHEITSHINWEISE.....	167	3. GERÄTEBESCHREIBUNG.....	174
1.1 Sicherheit von Kindern und schutzbedürftigen Personen.....	167	3.1 Gesamtansicht.....	174
1.2 Allgemeine Sicherheit.....	168	3.2 Zubehör.....	174
2. SICHERHEITSANWEISUNGEN.....	169	4. BEDIENFELD.....	175
2.1 Montage.....	169	4.1 Überblick – Bedienfeld.....	175
2.2 Elektrischer Anschluss.....	170	4.2 Display.....	176
2.3 Gebrauch.....	171	5. VOR DER ERSTEN VERWENDUNG.....	177
2.4 Reinigung und Pflege.....	172	5.1 Erste Reinigung	177
2.5 Pyrolytische Reinigung.....	172	5.2 Erste Verbindung.....	177
2.6 Dampfgaren.....	173	5.3 Erstes Vorheizen.....	177
2.7 Innenbeleuchtung.....	173	5.4 Einstellung: Wasserhärte.....	177
2.8 Wartung.....	173	6. TÄGLICHER GEBRAUCH.....	178
2.9 Entsorgung.....	174	6.1 Einstellung: Ofenfunktionen.....	179
		6.2 Einstellung: Dampf-Ofenfunktion.	179

6.3	Einstellung: Koch-Assistent.....	180	11.4	Erinnerungsfunktion Reinigen....	196
6.4	Ofenfunktionen.....	181	11.5	Benutzung: Entkalkung.....	196
6.5	Hinweise zu: Feuchte Umluft.....	183	11.6	Entkalkungserinnerungen.....	197
7.	UHRFUNKTIONEN.....	184	11.7	Benutzung: Spülen.....	197
7.1	Beschreibung der Uhrfunktionen.	184	11.8	Benutzung: Entleeren des Wassertanks.....	198
7.2	Einstellung: Uhrfunktionen.....	184	11.9	Aus- und Einbau: Tür.....	198
8.	VERWENDUNG DES ZUBEHÖRS.....	186	11.10	Austausch: Lampe.....	200
8.1	Einsetzen des Zubehörs.....	186	12.	FEHLERSUCHE.....	201
8.2	Temperatursensor.....	187	12.1	Was zu tun ist, wenn	201
8.3	Benutzung: Temperatursensor....	187	12.2	Handhabung: Fehlercodes.....	202
9.	ZUSATZFUNKTIONEN.....	189	12.3	Service-Daten.....	203
9.1	So speichern Sie: Favoriten.....	189	13.	ENERGIEEFFIZIENZ.....	203
9.2	Tastensperre.....	189	13.1	Produktinformation und Produktinformationsblatt.....	203
9.3	Automatische Abschaltung.....	190	13.2	Energiesparen.....	204
9.4	Kühlgebläse.....	190	14.	MENÜSTRUKTUR.....	205
10.	TIPPS UND HINWEISE.....	190	14.1	Menü.....	205
10.1	Garempfehlungen.....	190	14.2	Untermenü für: Reinigung.....	205
10.2	Feuchte Umluft.....	190	14.3	Untermenü für: Optionen.....	206
10.3	Feuchte Umluft - Empfohlenes Zubehör.....	191	14.4	Untermenü für: Setup.....	206
10.4	Gartabellen für Prüfinstitute.....	192	14.5	Untermenü von: Service.....	207
11.	REINIGUNG UND PFLEGE.....	193	15.	DAS IST GANZ EINFACH!.....	207
11.1	Hinweise zur Reinigung.....	193	16.	INFORMATIONEN ZUR ENTSORGUNG.....	208
11.2	Entfernen: Einhängegitter	194			
11.3	Benutzung: Pyrolytische Reinigung.....	194			

1. ⚠ SICHERHEITSHINWEISE

Lesen Sie vor der Montage und dem Gebrauch des Geräts zuerst die Bedienungsanleitung. Bei Verletzungen oder Schäden infolge nicht ordnungsgemäßer Montage oder Verwendung übernimmt der Hersteller keine Haftung. Bewahren Sie die Anleitung zum Nachschlagen an einem sicheren und zugänglichen Ort auf.

1.1 Sicherheit von Kindern und schutzbedürftigen Personen

- Das Gerät kann von Kindern ab 8 Jahren und Personen mit eingeschränkten physischen, sensorischen oder geistigen

Fähigkeiten oder mit mangelnder Erfahrung/mangelndem Wissen benutzt werden, wenn sie durch eine für ihre Sicherheit zuständige Person beaufsichtigt werden oder von dieser Person Anweisungen erhalten haben, wie das Gerät sicher zu bedienen ist und welche Gefahren bei nicht ordnungsgemäßer Bedienung bestehen. Kinder unter 8 Jahren und Personen mit schweren Behinderungen oder Mehrfachbehinderung sollten vom Gerät ferngehalten werden, wenn sie nicht ständig beaufsichtigt werden.

- Kinder sollten beaufsichtigt werden, um sicherzustellen, dass sie nicht mit dem Gerät.
- Halten Sie sämtliches Verpackungsmaterial von Kindern fern und entsorgen Sie es ordnungsgemäß.
- **WARNUNG:** Das Gerät und die zugänglichen Geräteteile werden während des Betriebs heiß. Halten Sie Kinder und Haustiere von dem Gerät fern, wenn es in Betrieb oder in der Abkühlphase ist.
- Falls Ihr Gerät mit einer Kindersicherung ausgestattet ist, empfehlen wir, diese einzuschalten.
- Kinder dürfen keine Reinigung und Wartung des Geräts ohne Beaufsichtigung durchführen.

1.2 Allgemeine Sicherheit

- Dieses Gerät ist nur zum Kochen bestimmt.
- Dieses Gerät ist für den Hausgebrauch in einem Einfamilienhaus in Innenräumen bestimmt.
- Dieses Gerät darf in Büros, Hotelzimmern, Gästezimmern in Pensionen, Bauernhöfen und anderen ähnlichen Unterkünften verwendet werden, wenn diese Nutzung das (durchschnittliche) Nutzungsniveau im Haushalt nicht überschreitet.
- Die Montage des Geräts und der Austausch des Kabels muss von einer Fachkraft vorgenommen werden.
- Verwenden Sie das Gerät nicht, bevor es in den Einbauschrank gesetzt wird.

- Vor Wartungsarbeiten ist das Gerät von der elektrischen Stromversorgung zu trennen.
- Wenn das Netzkabel beschädigt ist, muss es vom Hersteller, seinem autorisierten Kundenservice oder einer gleichermaßen qualifizierten Person ausgetauscht werden, um Gefahren durch elektrischen Strom zu vermeiden.
- **WARNUNG:** Vergewissern Sie sich, dass das Gerät ausgeschaltet ist, bevor Sie die Lampe austauschen, um einen Stromschlag zu vermeiden.
- **WARNUNG:** Das Gerät und die zugänglichen Geräteteile werden während des Betriebs heiß. Es ist darauf zu achten, die Heizelemente oder die Oberfläche des Garraums nicht zu berühren.
- Verwenden Sie stets Topfhandschuhe, um Zubehör oder Geschirr herauszunehmen oder zu verstauen.
- Verwenden Sie ausschließlich den für dieses Gerät empfohlenen KT Sensor (Kerntemperatursensor).
- Ziehen Sie die Einhängegitter zuerst vorne und dann hinten von den Seitenwänden weg. Setzen Sie die Einhängegitter in umgekehrter Reihenfolge ein.
- Reinigen Sie das Gerät nicht mit einem Dampfstrahlreiniger.
- Benutzen Sie zum Reinigen der Glastür keine scharfen Scheuermittel oder Metallschwämmchen; sie könnten die Glasfläche verkratzen und zum Zersplittern der Scheibe führen.
- Entfernen Sie vor der pyrolytischen Reinigung alle Zubehörteile und übermäßige Ansammlungen/ Ablagerungen aus dem Innenraum des Geräts.

2. SICHERHEITSANWEISUNGEN

2.1 Montage

**WARNUNG!**

Die Montage des Geräts darf nur von einer qualifizierten Fachkraft durchgeführt werden.

- Entfernen Sie das gesamte Verpackungsmaterial.

SICHERHEITSANWEISUNGEN

- Montieren Sie ein beschädigtes Gerät nicht und benutzen Sie es nicht.
- Halten Sie sich an die mitgelieferte Montageanleitung.
- Seien Sie beim Umsetzen des Gerätes vorsichtig, da es sehr schwer ist. Tragen Sie stets Sicherheitshandschuhe und festes Schuhwerk.
- Ziehen Sie das Gerät nicht am Griff.
- Montieren Sie das Gerät an einem sicheren und geeigneten Ort, der den Montageanforderungen entspricht.
- Die Mindestabstände zu anderen Geräten und Küchenmöbeln sind einzuhalten.
- Überprüfen Sie vor der Montage des Gerätes, ob sich die Gerätetür ungehindert öffnen lässt.
- Das Gerät ist mit einem elektrischen Kühlsystem ausgestattet. Es muss mit der elektrischen Stromversorgung betrieben werden.
- Das Einbaugerät muss die Stabilitätsanforderungen von DIN 68930 erfüllen.

Mindesthöhe des Einbaumöbels (Mindesthöhe des Schrankes unter der Arbeitsplatte)	578 (600) mm
Schrankbreite	560 mm
Schranksiefe	550 (550) mm
Höhe der Gerätevorderseite	594 mm
Höhe der Geräterückseite	576 mm
Breite der Gerätevorderseite	595 mm
Breite der Geräterückseite	559 mm
Gerätetiefe	567 mm
Geräteeinbautiefe	546 mm
Tiefe bei geöffneter Tür	1027 mm
Mindestgröße der Belüftungsöffnung. Öffnung auf der Rückseite unten	560x20 mm
Länge des Netzanschlusskabels. Das Kabel befindet sich in der rechten Ecke auf der Rückseite	1500 mm
Befestigungsschrauben	4x25 mm

2.2 Elektrischer Anschluss



WARNUNG!

Brand- und Stromschlaggefahr.

- Alle elektrischen Anschlüsse sind von einem geprüften Elektriker vorzunehmen.
- Das Gerät muss geerdet sein.
- Stellen Sie sicher, dass die Daten auf dem Typenschild mit den elektrischen Nennwerten der Netzspannung übereinstimmen.
- Schließen Sie das Gerät nur an eine ordnungsgemäß installierte Schutzkontaktsteckdose an.
- Verwenden Sie keine Mehrfachsteckdosen oder Verlängerungskabel.
- Achten Sie darauf, Netzstecker und Netzkabel nicht zu beschädigen. Falls das Netzkabel des Geräts ersetzt werden muss, lassen Sie diese Arbeit durch unseren autorisierten Kundendienst durchführen.
- Achten Sie darauf, dass das Netzkabel die Gerätetür oder die Nische unter dem Gerät nicht berührt oder in ihre Nähe gelangt, insbesondere wenn das Gerät eingeschaltet oder die Tür heiß ist.
- Alle Teile, die gegen direktes Berühren schützen, sowie die isolierten Teile müssen so befestigt werden, dass sie nicht ohne Werkzeug entfernt werden können.
- Stecken Sie den Netzstecker erst nach Abschluss der Montage in die Steckdose. Stellen Sie sicher, dass der Netzstecker nach der Montage noch zugänglich ist.
- Falls die Steckdose lose ist, schließen Sie den Netzstecker nicht an.
- Ziehen Sie nicht am Netzkabel, wenn Sie das Gerät von der Stromversorgung trennen möchten. Ziehen Sie stets am Netzstecker.
- Verwenden Sie nur geeignete Trenneinrichtungen: Überlastschalter, Sicherungen (Schraubsicherungen müssen aus dem Halter entfernt werden können), Fehlerstromschutzschalter und Schütze.
- Die elektrische Installation muss eine Trenneinrichtung aufweisen, mit der Sie das Gerät allpolig von der Stromversorgung trennen können. Die Trenneinrichtung muss mit einer Kontaktöffnungsbreite von mindestens 3 mm ausgeführt sein.
- Schließen Sie die Gerätetür ganz, bevor Sie den Netzstecker in die Steckdose stecken.
- Das Gerät wird mit einem Netzstecker und Netzkabel geliefert.

2.3 Gebrauch



WARNUNG!

Verletzungs-, Verbrennungs-, Stromschlag- oder Explosionsgefahr.

- Nehmen Sie keine technischen Änderungen am Gerät vor.
- Vergewissern Sie sich, dass die Lüftungsöffnungen nicht blockiert sind.
- Lassen Sie das Gerät während des Betriebs nicht unbeaufsichtigt.
- Schalten Sie das Gerät nach jedem Gebrauch aus.
- Gehen Sie beim Öffnen der Tür vorsichtig vor, wenn das Gerät in Betrieb ist. Es kann heiße Luft freigesetzt werden.
- Benutzen Sie das Gerät nicht mit nassen Händen oder wenn es mit Wasser Kontakt hat.
- Üben Sie keinen Druck auf die offene Tür aus.
- Verwenden Sie das Gerät nicht als Arbeits- oder Abstellfläche.
- Öffnen Sie die Gerätetür vorsichtig. Die Verwendung von Zutaten mit Alkohol kann eine Mischung aus Alkohol und Luft verursachen.
- Lassen Sie beim Öffnen der Tür keine Funken oder offenen Flammen mit dem Gerät in Kontakt kommen.
- Platzieren Sie keine entflammaren Produkte oder Gegenstände, die mit entflammaren Produkten benetzt sind, im Gerät, auf dem Gerät oder in der Nähe des Geräts.

**WARNUNG!**

Risiko von Schäden am Gerät.

- Um Beschädigungen und Verfärbungen der Emailbeschichtung zu vermeiden:
 - Stellen Sie feuerfestes Geschirr oder andere Gegenstände nicht direkt auf den Boden des Geräts.
 - Legen Sie keine Alufolie direkt auf den Boden des Garraums.
 - Füllen Sie kein Wasser direkt in das heiße Gerät.
 - Lassen Sie nach Abschluss des Garvorgangs kein feuchtes Geschirr oder feuchte Speisen im Gerät stehen.
 - Gehen Sie beim Herausnehmen oder Einsetzen des Zubehörs sorgfältig vor.
- Verfärbungen der Emaille- oder Edelstahlbeschichtung haben keine Auswirkung auf die Leistung des Geräts.
- Verwenden Sie eine tiefe Pfanne für feuchte Kuchen. Fruchtsäfte verursachen Flecken, die dauerhaft sein können.
- Kochen Sie immer bei geschlossener Gerätetür.
- Ist das Gerät hinter einer Möbelfront (wie etwa einer Tür) installiert, achten Sie darauf, dass die Tür während des Gerätebetriebs nicht geschlossen wird. Hinter einer geschlossenen Möbelfront können sich Hitze und Feuchtigkeit ansammeln und das Gerät, das Gehäuse oder den Boden beschädigen. Schließen Sie die Möbelfront nicht, bevor das Gerät nach dem Gebrauch völlig abgekühlt ist.

2.4 Reinigung und Pflege

**WARNUNG!**

Verletzungs-, Brandgefahr sowie Risiko von Schäden am Gerät.

- Schalten Sie das Gerät immer aus und ziehen Sie den Netzstecker aus der Steckdose, bevor Reinigungsarbeiten durchgeführt werden.
- Vergewissern Sie sich, dass das Gerät abgekühlt ist. Es besteht die Gefahr, dass die Glasscheiben brechen.
- Ersetzen Sie die Türglasscheiben umgehend, wenn sie beschädigt sind. Wenden Sie sich an einen autorisierten Kundendienst.
- Gehen Sie beim Aushängen der Tür vorsichtig vor. Die Tür ist schwer!
- Reinigen Sie das Gerät regelmäßig, um eine Verschlechterung des Oberflächenmaterials zu verhindern.
- Reinigen Sie das Gerät mit einem weichen, feuchten Tuch. Verwenden Sie ausschließlich Neutralreiniger. Benutzen Sie keine Scheuermittel, scheuernde Reinigungsschwämmchen, Lösungsmittel oder Metallgegenstände.
- Falls Sie ein Backofenspray verwenden, befolgen Sie die Sicherheitsanweisungen auf seiner Verpackung.

2.5 Pyrolytische Reinigung

**WARNUNG!**

Im Pyrolyse-Modus besteht Verletzungs- und Brandgefahr und es können chemische Emissionen (Dämpfe) austreten.

- Entfernen Sie vor der Pyrolyse und dem ersten Vorheizen Folgendes aus dem Garraum:
 - Speisereste, Öl oder Fettansammlungen / -ablagerungen.

- Alle abnehmbaren Gegenstände (die mit dem Gerät mitgeliefert werden, wie z. B. Regale, Seitenleisten usw.), insbesondere alle antihaftbeschichteten Töpfe, Pfannen, Backbleche, Utensilien usw.
- Lesen Sie sorgfältig alle Anweisungen zur pyrolytischen Reinigung durch.
- Halten Sie Kinder während der Pyrolyse vom Gerät fern. Das Gerät wird sehr heiß und die heiße Luft wird durch die vorderen Kühllüftungsöffnungen freigesetzt.
- Die pyrolytische Reinigung erfolgt bei sehr hoher Temperatur und kann Dämpfe von Lebensmittelrückständen und Gerätematerialien freisetzen. Beachten Sie Folgendes:
 - Sorgen Sie während und nach der Pyrolyse für eine gute Belüftung.
 - Sorgen Sie während und nach dem ersten Vorheizen für eine gute Belüftung.
- Während und nach der Pyrolyse kein Wasser auf die Backofentür geben, um eine Beschädigung der Glasscheiben zu vermeiden.
- Die von den Pyrolyse-Backöfen / Speiseresten freigesetzten Dämpfe sind ungefährlich für Menschen, einschließlich Kinder und Personen mit Gesundheitsproblemen.
- Halten Sie Haustiere während und nach der Pyrolyse und dem ersten Aufheizen vom Gerät fern. Kleine Haustiere (insbesondere Vögel und Reptilien) können sehr empfindlich auf Temperaturschwankungen und emittierte Dämpfe reagieren.
- Antihaftbeschichtungen auf Töpfen, Pfannen, Backblechen und Kochutensilien usw. können durch die hohen Temperaturen während der pyrolytischen Reinigung aller pyrolytischen Backöfen beschädigt werden und geringfügige Mengen an gesundheitsschädlichen Dämpfen freisetzen.

2.6 Dampfgeraren



WARNUNG!

Verbrennungsgefahr sowie Risiko von Schäden am Gerät.

- Freigesetzter Dampf kann Verbrennungen verursachen:
 - Gehen Sie beim Öffnen der Tür vorsichtig vor, wenn die Funktion eingeschaltet ist. Es kann heißer Dampf austreten.
 - Öffnen Sie die Gerätetür vorsichtig nach dem Dampfgeraren.

2.7 Innenbeleuchtung



WARNUNG!

Stromschlaggefahr.

- Bezüglich der Lampe(n) in diesem Gerät und separat verkaufter Ersatzlampen: Diese Lampen müssen extremen physikalischen Bedingungen in Haushaltsgeräten standhalten, wie z.B. Temperatur, Vibration, Feuchtigkeit, oder sollen Informationen über den Betriebszustand des Gerätes anzeigen. Sie sind nicht für den Einsatz in anderen Geräten vorgesehen und nicht für die Raumbelichtung geeignet.
- Dieses Produkt enthält eine Lichtquelle der Energieeffizienzklasse G.
- Verwenden Sie nur Lampen mit der gleichen Leistung .

2.8 Wartung

- Wenden Sie sich zur Reparatur des Geräts an den autorisierten Kundendienst.
- Dabei dürfen ausschließlich Originalersatzteile verwendet werden.

GERÄTEBESCHREIBUNG

2.9 Entsorgung



WARNUNG!

Verletzungs- und Erstickungsgefahr.

- Informationen zur Entsorgung des Geräts erhalten Sie von Ihrer Gemeindeverwaltung.
- Trennen Sie das Gerät von der Stromversorgung.
- Schneiden Sie das Netzkabel in der Nähe des Geräts ab, und entsorgen Sie es.
- Entfernen Sie das Türschloss, um zu verhindern, dass sich Kinder, oder Haustiere im Gerät einschließen.

3. GERÄTEBESCHREIBUNG

3.1 Gesamtansicht

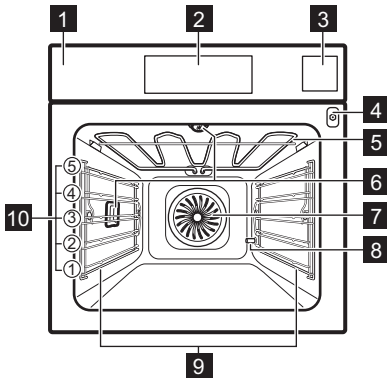

- 1 Bedienfeld
- 2 Display
- 3 Wassertank
- 4 Buchse für den Temperatursensor
- 5 Heizelement
- 6 Lampe
- 7 Ventilator
- 8 Entkalkungsrohr Ausgang
- 9 Einschubschienen, herausnehmbar
- 10 Einschubebenen

3.2 Zubehör

Kombirost

Für Kochgeschirr, Kuchenformen, Braten.

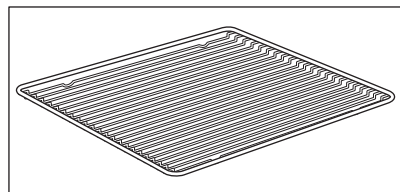

Backblech

Für Kuchen und Plätzchen.

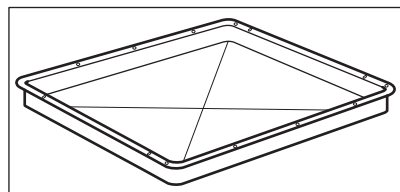

Brat- und Fettpfanne

Zum Backen und Braten oder zum Auffangen von abtropfendem Fett.

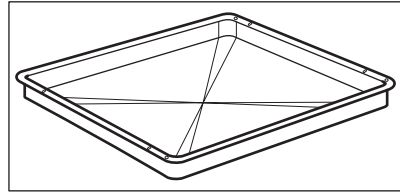

Temperatursensor

Zum Messen der Temperatur in der Speise.

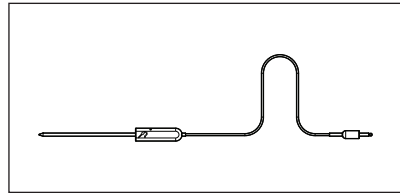

4. BEDIENFELD

4.1 Überblick – Bedienfeld

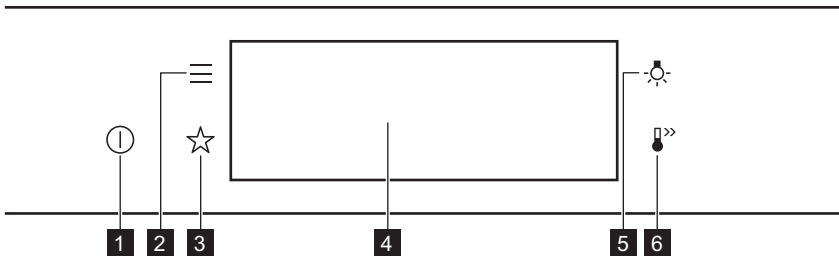







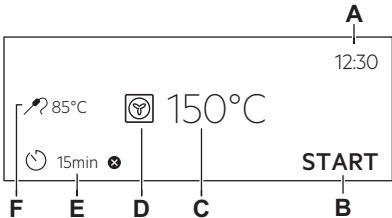

1	EIN / AUS	Gedrückt halten, um das Gerät ein- und auszuschalten.
2	Menü	Listet die Gerätefunktionen auf.
3	Favoriten	Liste der bevorzugten Einstellungen.
4	Display	Zeigt die aktuellen Einstellungen des Geräts an.
5	Lichtschalter	Ein- und Ausschalten der Beleuchtung.
6	Schnellaufheizung	Ein- und Ausschalten der Funktion: Schnellaufheizung.

 <p>Drücken Sie</p>	 <p>Wischen</p>	 <p>Gedrückt halten</p>
<p>Berühren Sie die Oberfläche mit der Fingerspitze.</p>	<p>Bewegen Sie die Fingerspitze über die Oberfläche.</p>	<p>Berühren Sie die Oberfläche 3 Sekunden lang.</p>

4.2 Display

	<p>Display mit Tastenfunktionen.</p> <ul style="list-style-type: none"> A. Uhrzeit B. START/STOP C. Temperatur D. Ofenfunktionen E. Kurzzeitwecker F. Temperatursensor (nur ausgewählte Modelle)
-----------------------------------------------------------------------------------	--------------------------------------------------------------------------------------------------------------------------------------------------------------------------------------------------------------------------------------------------------------

Display-Anzeigen

<p>Grundlegende Anzeigen - Navigieren im Display.</p>			
<p>OK Bestätigen der Auswahl / Einstellung.</p>	<p> Zurückblättern um eine Menüebene.</p>	<p> Rückgängig machen der letzten Aktion.</p>	<p> Ein- und Ausschalten der Optionen.</p>
<p>Alarmsignal Funktionsanzeigen – der Signalton ertönt nach Ablauf der eingestellten Kochzeit.</p>			
<p> Die Funktion ist eingeschaltet.</p>	<p> Die Funktion ist eingeschaltet. Der Garvorgang stoppt automatisch.</p>	<p> Das Alarmsignal ist ausgeschaltet.</p>	
<p>Timer-Anzeigen</p>			
<p> Einstellen der Funktion: Zeitvorwahl.</p>	<p> Abbrechen der Einstellung.</p>		



5. VOR DER ERSTEN VERWENDUNG



WARNUNG!

Siehe Kapitel Sicherheitshinweise.

5.1 Erste Reinigung



		
Schritt 1	Schritt 2	Schritt 3
Entfernen Sie alle Zubehörteile und die herausnehmbaren Einhängegitter aus dem Gerät.	Reinigen Sie das Gerät und das Zubehör nur mit einem Mikrofasertuch, warmem Wasser und einem milden Reinigungsmittel.	Setzen Sie die Zubehörteile und die herausnehmbaren Einhängegitter in das Gerät ein.

5.2 Erste Verbindung

Nach der ersten Verbindung zeigt das Display eine Willkommensnachricht an. Sie müssen folgende Einstellungen vornehmen: Sprache, Helligkeit, Tastentöne, Lautstärke, Wasserhärte, Uhrzeit.

5.3 Erstes Vorheizen

Den leeren Ofen vor der ersten Inbetriebnahme vorheizen.

Schritt 1	Entfernen Sie alle Zubehörteile und die herausnehmbaren Einhängegitter aus dem Backofen.
Schritt 2	Stellen Sie die Höchsttemperatur für folgende Funktion ein:  . Lassen Sie den Ofen 1 Stunde lang eingeschaltet.
Schritt 3	Stellen Sie die Höchsttemperatur für folgende Funktion ein:  . Lassen Sie den Ofen 15 Min. lang eingeschaltet.







Der Ofen kann während des Vorheizens Geruch und Rauch verströmen. Stellen Sie sicher, dass der Raum belüftet ist.

5.4 Einstellung: Wasserhärte





Nachdem Sie den Backofen an die Spannungsversorgung angeschlossen haben, müssen Sie den Grad der Wasserhärte einstellen.

Verwenden Sie das Reagenzpapier oder kontaktieren Sie Ihren Wasserversorger, um die Wasserhärte zu prüfen.

TÄGLICHER GEBRAUCH

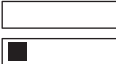
			
Schritt 1	Schritt 2	Schritt 3	Schritt 4
Geben Sie das Reagenzpapier etwa 1 Sekunde lang in das Wasser. Halten Sie das Reagenzpapier nicht unter fließendes Wasser.	Schütteln Sie überschüssiges Wasser vom Reagenzpapier ab.	Überprüfen Sie nach 1 Minute die Wasserhärte mithilfe der Tabelle unten.	Stellen Sie die Wasserhärte ein: Menü / Einstellungen / Setup / Wasserhärte.
<p>i Die Farben des Reagenzpapiers ändern sich weiterhin. Überprüfen Sie die Wasserhärte innerhalb von 1 Minute nach dem Test.</p>			
<p>Sie können die Wasserhärte in folgendem Menü ändern: Einstellungen / Setup / Wasserhärte.</p>			

Die Tabelle zeigt den Bereich der Wasserhärte (dH) mit dem zugehörigen Kalkgehalt und die Wassereinstufung. Stellen Sie den Grad der Wasserhärte gemäß der Tabelle ein.

Wasserhärte		Reagenzpapier	Kalkgehalt (mmol/l)	Kalkgehalt (mg/l)	Wassereinstufung
Grad	dH				
1	0 - 7		0 - 1.3	0 - 50	weich
2	8 - 14		1.4 - 2.5	51 - 100	mittelhart
3	15 - 21		2.6 - 3.8	101 - 150	hart
4	≥ 22		≥ 3,9	≥ 151	sehr hart

Beträgt der Grad der Wasserhärte 4, füllen Sie den Wassertank mit Tafelwasser.

6. TÄGLICHER GEBRAUCH



WARNUNG!

Siehe Kapitel Sicherheitshinweise.

6.1 Einstellung: Ofenfunktionen

Schritt 1	Schalten Sie den Backofen ein. Das Display zeigt die Standard-Ofenfunktion an.
Schritt 2	Drücken Sie auf das Symbol der Ofenfunktion, um das Untermenü aufzurufen.
Schritt 3	Wählen Sie die Ofenfunktion und drücken Sie: OK . Das Display zeigt: Temperatur.
Schritt 4	Temperatur einstellen. Drücken Sie: OK .
Schritt 5	Drücken Sie: START . Temperatursensor – Sie können den Sensor jederzeit vor oder während des Kochens anschließen.
Drücken Sie STOP , um die Ofenfunktion auszuschalten	
Schritt 6	Schalten Sie den Backofen aus.

6.2 Einstellung: Dampf-Ofenfunktion

Schritt 1	Schalten Sie den Backofen ein. Wählen Sie das Symbol der Ofenfunktion und drücken Sie darauf, um das Untermenü aufzurufen.
Schritt 2	Drücken Sie  . Stellen Sie die Dampf-Ofenfunktion ein.
Schritt 3	Drücken Sie: OK . Das Display zeigt die Temperatureinstellungen an.
Schritt 4	Stellen Sie die Temperatur ein.
Schritt 5	Drücken Sie: OK .
Schritt 6	Drücken Sie auf den Deckel des Wassertanks, um ihn zu öffnen.

TÄGLICHER GEBRAUCH

Schritt 7	<p>Füllen Sie den Wassertank bis zum Höchststand mit kaltem Wasser auf (ca. 950 ml), bis ein akustisches Signal ertönt oder das Display eine Meldung anzeigt. Füllen Sie den Wassertank nicht bis über den maximalen Füllstand hinaus. Ansonsten besteht das Risiko eines Wasseraustritts oder -überlaufs und der Beschädigung von Einrichtungsgegenständen.</p> <div style="border: 1px solid black; padding: 5px;"><p> WARNUNG! Verwenden Sie nur kaltes Leitungswasser. Verwenden Sie kein gefiltertes (entmineralisiertes) oder destilliertes Wasser. Verwenden Sie keine anderen Flüssigkeiten. Füllen Sie keine brennbaren oder alkoholischen Flüssigkeiten in den Wassertank.</p></div>
Schritt 8	<p>Schieben Sie den Wassertank in seine ursprüngliche Position.</p>
Schritt 9	<p>Drücken Sie: START . Der Dampf erscheint nach circa 2 Min. Bei Erreichen der eingestellten Temperatur ertönt ein Signalton.</p>
Schritt 10	<p>Wenn das Wasser im Wassertank zur Neige geht, ertönt der Signalton. Befüllen Sie den Wassertank neu.</p>
Schritt 11	<p>Schalten Sie den Backofen aus.</p>
Schritt 12	<p>Leeren Sie den Wassertank nach dem Garvorgang. Siehe Kapitel „Reinigung und Pflege“, Entleeren des Wassertanks.</p>
Schritt 13	<p>Restwasser kann sich im Garraum niederschlagen. Öffnen Sie die Backofentür nach dem Garen vorsichtig. Wenn der Backofen abgekühlt ist, trocknen Sie den Garraum mit einem weichen Tuch.</p>

6.3 Einstellung: Koch-Assistent

Jedes Gericht in diesem Untermenü hat eine empfohlene Funktion und Temperatur. Sie können die Zeit und Temperatur anpassen.



Einige der Speisen können Sie auch mit der folgenden Funktion zubereiten:

- Gewichtsautomatik
- Temperatursensor

Die Garstufe für die Speise:







- Blutig oder Weniger
- Mittel
- Durch oder Mehr

Schritt 1	<p>Schalten Sie den Backofen ein.</p>
------------------	---------------------------------------



Schritt 2	Drücken Sie:  .
Schritt 3	Drücken Sie:  . Gehen Sie zu: Koch-Assistent.
Schritt 4	Wählen Sie ein Gericht oder eine Speisenart aus.
Schritt 5	Drücken Sie: START.

6.4 Ofenfunktionen







STANDARDFUNKTIONEN

Ofenfunktion	Anwendung
 Grill	Zum Grillen dünner Lebensmittel und zum Toasten von Brot.
 Heißluftgrillen	Zum Braten großer Fleischstücke oder von Geflügel mit Knochen auf einer Ebene. Gratinieren und Überbacken.
 Heißluft	Zum Backen auf bis zu drei Einschubebenen gleichzeitig und zum Dörren von Lebensmitteln. Stellen Sie eine 20 - 40 °C niedrigere Backofentemperatur als bei Ober-/Unterhitze ein.
 Tiefkühlgerichte	Lässt Fertiggerichte (z. B. Pommes frites, Kroketten oder Frühlingsrollen) schön knusprig werden.
 Ober-/Unterhitze	Backen und Braten von Speisen auf einer Einschubebene.
 Pizzastufe	Zum Backen von Pizza. Für ein intensives Überbacken und einen knusprigen Boden.

TÄGLICHER GEBRAUCH



Ofenfunktion	Anwendung
 Unterhitze	Zum Backen von Kuchen mit knusprigen Böden und zum Einkochen von Lebensmitteln.
 Gärstufe	Zur Verkürzung der Gärzeit des Hefeteigs. Dadurch wird die Oberfläche vor dem Austrocknen bewahrt und der Teig elastisch gehalten.

SONDERFUNKTIONEN

Ofenfunktion	Gerät
 Einkochen	Zum Einkochen von Gemüse (z. B. Gurken).
 Dörren	Zum Dörren von Obst, Gemüse und Pilzen in Scheiben.
 Teller wärmen	Zum Vorwärmen von Tellern vor dem Servieren.
 Auftauen	Zum Auftauen von Lebensmitteln (Gemüse und Obst). Die Auftauzeit hängt von der Menge und Größe der gefrorenen Lebensmittel ab.
 Überbacken	Für Gerichte wie Lasagne oder Kartoffelgratin. Zum Gratinieren und Überbacken.
 Niedertemperaturgaren	Für zarte, saftige Braten.
 Warmhalten	Zum Warmhalten von Speisen.

Ofenfunktion	Gerät
 <p>Feuchte Umluft</p>	<p>Diese Funktion ist entwickelt worden, um während des Kochvorgangs Energie zu sparen. Wenn Sie diese Funktion nutzen, kann die Temperatur im Garraum von der eingestellten Temperatur abweichen. Es wird die Restwärme genutzt. Die Wärmeleistung kann geringer sein. Weitere Informationen zu folgenden Themen finden Sie im Kapitel „Täglicher Gebrauch“: Feuchte Umluft.</p>

DAMPFFUNKTIONEN

Ofenfunktion	Anwendung
 <p>Regenerieren</p>	<p>Das Aufwärmen von Speisen mit Dampf verhindert die Austrocknung der Oberfläche. Die Hitze wird sanft und gleichmäßig verteilt und belebt den Geschmack sowie das Aroma der Speisen, als ob sie frisch zubereitet wären. Mit dieser Funktion können Sie die Speisen direkt auf einem Teller aufwärmen. Sie können mehrere Teller gleichzeitig auf verschiedenen Einschubebenen aufwärmen.</p>
 <p>Brot backen</p>	<p>Verwenden Sie diese Funktion, um Brot/Brötchen mit einem sehr guten, professionellen Ergebnis hinsichtlich Knusprigkeit, Farbe und glänzender Kruste zu backen.</p>
 <p>Feuchtigkeit, niedrig</p>	<p>Diese Funktion ist geeignet für Fleisch, Geflügel, Ofengerichte und Aufläufe. Durch die Kombination von Dampf und Hitze werden Fleischstücke zart und saftig und erhalten eine knusprige Oberfläche.</p>

6.5 Hinweise zu: Feuchte Umluft

Diese Funktion wurde zur Einhaltung der Energieeffizienzklasse und der Ökodesign-Anforderungen (gemäß EU 65/2014 und EU 66/2014) verwendet. Tests gemäß: IEC/EN 60350-1

Die Backofentür sollte während des Garvorgangs geschlossen bleiben, damit die Funktion nicht unterbrochen wird. So wird gewährleistet, dass der Backofen mit der höchsten Energieeffizienz arbeitet.

Wenn Sie diese Funktion verwenden, schaltet sich die Backofenbeleuchtung automatisch nach 30 Sekunden aus.

Näheres zum Garen finden Sie im Kapitel „Tipps und Hinweise“, Feuchte Umluft. Allgemeine Empfehlungen zum Energiesparen finden Sie im Kapitel „Energieeffizienz“, Energiesparen.

7. UHRFUNKTIONEN

7.1 Beschreibung der Uhrfunktionen

Uhrfunktionen	Anwendung
Garzeitdauer	Einstellen der Garzeitdauer. Max. 23 Std. 59 Min.
Optionen nach Ablauf	Einstellung, was passiert, wenn der Timer mit dem Zählen aufhört.
Zeitvorwahl	Verzögerung des Starts und/oder Endes des Kochens.
Zeitverlängerung	Verlängern der Gardauer.
Erinnerung	Einstellen eines Countdowns. Max. 23 Std. 59 Min. Diese Funktion wirkt sich nicht auf den Betrieb des Geräts aus.
Uptimer	Überwachung der Einschaltdauer der Funktion. Uptimer - Sie können sie ein- oder ausschalten.

7.2 Einstellung: Uhrfunktionen

Einstellen der Uhr	
Schritt 1	Drücken Sie: Uhrzeit.
Schritt 2	Stellen Sie die Zeit ein. Drücken Sie: OK.

Einstellen der Gardauer	
Schritt 1	Wählen Sie die Ofenfunktion und stellen Sie die Temperatur ein.
Schritt 2	Drücken Sie:  .
Schritt 3	Stellen Sie die Zeit ein. Drücken Sie: OK.

Auswählen der Option „Ende“	
Schritt 1	Wählen Sie die Ofenfunktion und stellen Sie die Temperatur ein.
Schritt 2	Drücken Sie:  .
Schritt 3	Stellen Sie die Gardauer ein.
Schritt 4	Drücken Sie: ● ● ● .
Schritt 5	Drücken Sie: Optionen nach Ablauf.
Schritt 6	Wählen Sie die gewünschte: Optionen nach Ablauf.
Schritt 7	Drücken Sie: OK . Wiederholen Sie die Aktion, bis das Display den Hauptbildschirm anzeigt.

Verzögerung des Starts des Garvorgangs	
Schritt 1	Wählen Sie eine Ofenfunktion und die Temperatur.
Schritt 2	Drücken Sie:  .
Schritt 3	Stellen Sie die Gardauer ein.
Schritt 4	Drücken Sie: ● ● ● .
Schritt 5	Drücken Sie: Zeitvorwahl.
Schritt 6	Wählen Sie den Wert.
Schritt 7	Drücken Sie: OK . Wiederholen Sie die Aktion, bis das Display den Hauptbildschirm anzeigt.

VERWENDUNG DES ZUBEHÖRS

Verlängern der Gardauer

Wenn 10 % der Gardauer verbleiben und die Speise nicht fertig zu sein scheint, können Sie die Gardauer verlängern. Sie können auch die Ofenfunktion ändern.

Drücken Sie **+1min**, um die Gardauer zu verlängern.

Ändern der Timer-Einstellungen

Schritt 1 Drücken Sie: .

Schritt 2 Stellen Sie den Timerwert ein.

Schritt 3 Drücken Sie: **OK**.

Sie können die eingestellte Zeit jederzeit während des Garvorgangs ändern.

8. VERWENDUNG DES ZUBEHÖRS



WARNUNG!

Siehe Kapitel Sicherheitshinweise.

8.1 Einsetzen des Zubehörs

Die kleine Einkerbung auf der Oberseite erhöht die Sicherheit. Die Vertiefungen sind auch Kippsicherungen. Durch den umlaufend erhöhten Rand des Rosts ist das Kochgeschirr gegen Abrutschen vom Rost gesichert.

Kombirost:

Schieben Sie den Rost zwischen die Führungsschienen der Einhängegitter.

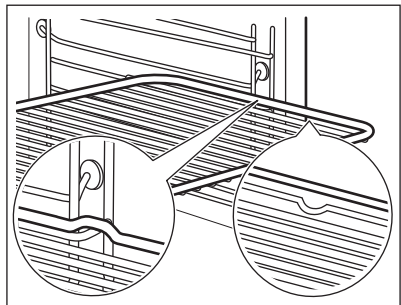

Backblech / Auflauffanne:

Schieben Sie das Backblech zwischen die Führungsstäbe der Einhängegitter.

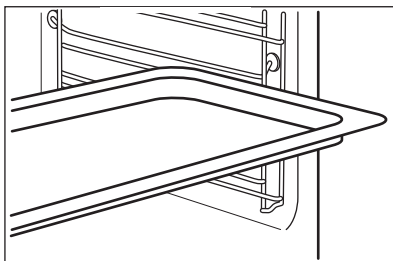

8.2 Temperatursensor

Temperatursensor – misst die Temperatur im Inneren der Speise. Sie können ihn mit jeder Ofenfunktion verwenden.

Es gibt zwei Temperatureinstellungen:



Backofentemperatur: mindestens 120 °C.



Die Backofentemperatur.

Für beste Garergebnisse:

Die Zutaten sollten Raumtemperatur haben.

Verwenden Sie ihn nicht für flüssige Speisen.

Er muss während des Garvorgangs in der Speise bleiben.

Der Backofen berechnet das voraussichtliche Ende des Garvorgangs. Es ist abhängig von der Menge des Garguts, der eingestellten Ofenfunktion und der Temperatur.

8.3 Benutzung: Temperatursensor

Schritt 1	Schalten Sie den Backofen ein.
Schritt 2	Stellen Sie die Ofenfunktion und, falls notwendig, die Temperatur ein.
Schritt 3	Einsetzen: Temperatursensor.
Fleisch, Geflügel und Fisch	Auflauf

VERWENDUNG DES ZUBEHÖRS

Führen Sie die Spitze des Temperatursensor in der Mitte und am dicksten Teil des Fleischstücks oder Fisches ein. Stellen Sie sicher, dass sich mindestens 3/4 des Temperatursensor im Gericht befindet.

Führen Sie die Spitze des Temperatursensor genau in der Mitte des Auflaufs ein. Temperatursensor sollte während des Backens richtig positioniert sein. Verwenden Sie hierzu eine feste Zutat. Verwenden Sie den Rand der Backform zur Unterstützung des Silikongriffs des Temperatursensor. Die Spitze des Temperatursensor darf den Boden einer Backform nicht berühren.

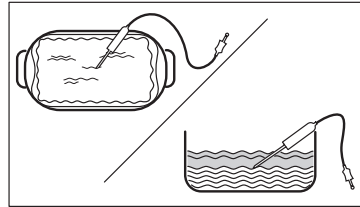
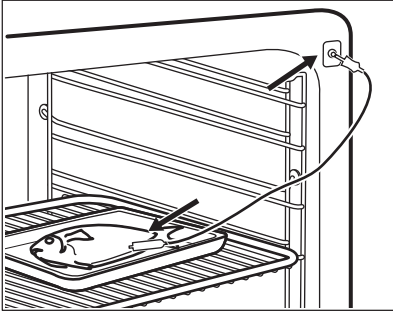

**Schritt
4**

Stecken Sie den Temperatursensor in die Buchse vorne am Ofen. Das Display zeigt die aktuelle Temperatur an: Temperatursensor.

**Schritt
5**

Drücken Sie , um die Kerntemperatur des Sensors einzustellen.

**Schritt
6**

Drücken Sie ● ● ●, um die bevorzugte Option einzustellen:

- Alarmsignal – Der Signalton ertönt, wenn die Speise die Kerntemperatur erreicht.
- Alarmsignal und Stoppen des Ofens – Der Signalton ertönt und der Ofen schaltet sich aus, wenn die Speise die Kerntemperatur erreicht.

**Schritt
7**

Wählen Sie die Option und drücken Sie wiederholt: **OK**, um den Hauptbildschirm aufzurufen.

**Schritt
8**



Drücken Sie: **START** .
Wenn die Speise die eingestellte Temperatur erreicht, ertönt ein Signalton. Sie können den Garprozess anhalten oder fortsetzen, um sicherzustellen, dass die Speise durchgegart ist.

Schritt 9	Ziehen Sie den Stecker des Temperatursensor aus der Steckdose und nehmen Sie das Gericht aus dem Ofen.
	 WARNUNG! Es besteht das Risiko von Verbrennungen, da der Temperatursensor heiß wird. Seien Sie vorsichtig, wenn Sie den Stecker ziehen und den Sensor aus dem Gargut nehmen.

9. ZUSATZFUNKTIONEN



9.1 So speichern Sie: Favoriten

Sie können Ihre bevorzugten Einstellungen, wie die Ofenfunktion, die Gardauer, Temperatur oder die Reinigungsfunktion speichern. Sie können 3 Favoriten speichern.

Schritt 1	Schalten Sie das Gerät ein.
Schritt 2	Wählen Sie die gewünschte Einstellung aus.
Schritt 3	Drücken Sie:  . Wählen Sie: Favoriten.
Schritt 4	Wählen Sie: Aktuelle Einstellungen speichern.
Schritt 5	Drücken Sie +, um die Einstellung hinzuzufügen zur Liste: Favoriten. Drücken Sie OK.
<p> – zum Zurücksetzen der Einstellung drücken.</p> <p> – zum Abbrechen der Einstellung drücken.</p>	

9.2 Tastensperre

Diese Funktion verhindert ein versehentliches Verstellen der Ofenfunktion.



Schritt 1	Schalten Sie das Gerät ein.
Schritt 2	Stellen Sie eine Backofenfunktion ein.
Schritt 3	 ,  – gleichzeitig drücken, um die Funktion einzuschalten.

TIPPS UND HINWEISE

Zum Ausschalten der Funktion wiederholen Sie Schritt 3.

9.3 Automatische Abschaltung

Aus Sicherheitsgründen schaltet sich das Gerät nach einiger Zeit aus, wenn eine Ofenfunktion eingeschaltet ist und Sie die Einstellungen nicht ändern.

 (°C)	 (Std.)
30 - 115	12.5
120 - 195	8.5
200 - 245	5.5
250 - max.	3

Die Abschaltautomatik funktioniert nicht mit den Funktionen: Backofenbeleuchtung, Temperatursensor, Ende, Niedertemperaturgaren.

9.4 Kühlgebläse

Wenn das Gerät in Betrieb ist, schaltet sich das Kühlgebläse automatisch ein, um die Oberflächen des Geräts kühl zu halten. Nach dem Abschalten des Geräts kann das Kühlgebläse weiterlaufen, bis das Gerät abgekühlt ist.

10. TIPPS UND HINWEISE





10.1 Garempfehlungen



Die Temperaturen und Garzeiten in den Tabellen sind nur Richtwerte. Sie hängen von den Rezepten sowie der Qualität und Menge der verwendeten Zutaten ab.
Ihr Gerät backt oder brät unter Umständen anders als Ihr früheres Gerät. Die Hinweise unten enthalten die empfohlenen Einstellungen für Temperatur, Gardauer und Einschubebene für die einzelnen Speisen.
Finden Sie für ein bestimmtes Rezept keine konkreten Angaben, orientieren Sie sich an einem ähnlichem Rezept.
Weitere Garempfehlungen finden Sie in den Kochtabellen auf unserer Website. Um die Gartipps zu finden, überprüfen Sie die PNC-Nummer auf dem Typenschild, das sich am vorderen Rahmen des Garraums befindet.



10.2 Feuchte Umluft

Beachten Sie für beste Ergebnisse die unten in der Tabelle aufgeführten Empfehlungen.

		 (°C)		 (Min.)
Brötchen, süß, 16 Stück	Backblech oder tiefes Blech	180	2	25 - 35
Biskuitrolle	Backblech oder tiefes Blech	180	2	15 - 25
Fisch, ganz, 0,2 kg	Backblech oder tiefes Blech	180	3	15 - 25
Plätzchen, 16 Stück	Backblech oder tiefes Blech	180	2	20 - 30
Makronen, 24 Stück	Backblech oder tiefes Blech	160	2	25 - 35
Muffins, 12 Stück	Backblech oder tiefes Blech	180	2	20 - 30
Kleingebäck, pi- kant, 20 Stück	Backblech oder tiefes Blech	180	2	20 - 30
Mürbeteigplätz- chen, 20 Stück	Backblech oder tiefes Blech	140	2	15 - 25
Törtchen, 8 Stück	Backblech oder tiefes Blech	180	2	15 - 25

10.3 Feuchte Umluft - Empfohlenes Zubehör

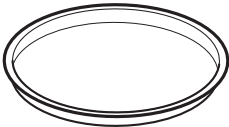
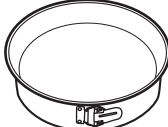
Verwenden Sie die dunklen und nicht reflektierenden Formen und Behälter. Sie haben eine bessere Wärmeabsorption als helle Farbe und reflektierende Schüsseln.





			
Pizzapfanne	Backform	Förmchen	Tortenbodenform
Dunkel, nicht reflektierend 28 cm Durchmesser	Dunkel, nicht reflektierend 26 cm Durchmesser	Keramikform 8 cm Durch- messer, 5 cm Höhe	Dunkel, nicht reflektierend 28 cm Durchmesser

10.4 Gartabellen für Prüfinstitute

Informationen für Prüfinstitute





Tests gemäß EN 60350, IEC 60350.

Backen auf einer Ebene – Backen in Backformen





		 °C	 Min	
Biskuit, fettfrei	Heißluft	160	45 - 60	2
Biskuit, fettfrei	Ober-/Unterhitze	160	45 - 60	2
Apfelkuchen, 2 Formen à Ø 20 cm	Heißluft	160	55 - 65	2
Apfelkuchen, 2 Formen à Ø 20 cm	Ober-/Unterhitze	180	55 - 65	1
Mürbeteiggebäck	Heißluft	140	25 - 35	2
Mürbeteiggebäck	Ober-/Unterhitze	140	25 - 35	2





Backen auf einer Ebene – Kekse

Nutzen Sie die dritte Einschubebene.

		 °C	 Min
Törtchen, 20 pro Blech, Hei- zen Sie den leeren Back- ofen vor	Heißluft	150	20 - 30
Törtchen, 20 pro Blech, Hei- zen Sie den leeren Back- ofen vor	Ober-/Unterhitze	170	20 - 30





Backen auf mehreren Ebenen – Kekse

		 °C	 Min	
Mürbeteiggebäck	Heißluft	140	25 - 45	2 / 4

		 °C	 Min	
Törtchen, 20 pro Blech, Heizen Sie den leeren Backofen vor	Heißluft	150	25 - 35	1 / 4
Biskuit, fettfrei	Heißluft	160	45 - 55	2 / 4
Apfelkuchen, 1 Backform pro Gitter (Ø 20 cm)	Heißluft	160	55 - 65	2 / 4

Grill

Heizen Sie den leeren Backofen 5 Minuten lang vor.
Grillen Sie bei maximaler Temperatureinstellung.

		 Min	
Toast	Grill	1 - 2	5
Rindersteak, Nach der Hälfte der Zeit wenden	Grill	24 - 30	4

11. REINIGUNG UND PFLEGE



WARNUNG!

Siehe Kapitel Sicherheitshinweise.

11.1 Hinweise zur Reinigung

 Reinigungs- mittel	Reinigen Sie die Vorderseite des Geräts nur mit einem Mikrofaser Tuch mit warmem Wasser und einem milden Reinigungsmittel.
	Reinigen Sie die Metalloberflächen mit einer geeigneten Reinigungslösung.
	Reinigen Sie Flecken mit einem milden Reinigungsmittel.

REINIGUNG UND PFLEGE

 Täglicher Gebrauch	Reinigen Sie den Garraum nach jedem Gebrauch. Fettansammlungen oder andere Speisereste könnten einen Brand verursachen.
	Lassen Sie die Speisen nicht länger als 20 Minuten im Gerät stehen. Trocknen Sie den Garraum nach jedem Gebrauch nur mit einem Mikrofasertuch ab.

 Zubehör	Reinigen Sie alle Zubehörteile nach jedem Gebrauch und lassen Sie sie trocknen. Verwenden Sie nur ein Mikrofasertuch mit warmem Wasser und einem milden Reinigungsmittel. Reinigen Sie die Zubehörteile nicht im Geschirrspüler.
	Reinigen Sie das Zubehör mit Antihafbeschichtung nicht mit Scheuermitteln oder scharfkantigen Gegenständen.

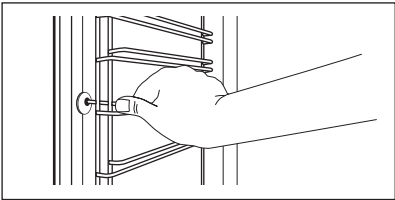

11.2 Entfernen: Einhängegitter

Entfernen Sie Eihängegitter zur Reinigung des Backofens.

Schritt 1	Schalten Sie den Backofen aus und warten Sie, bis er abgekühlt ist.	
Schritt 2	Ziehen Sie die Eihängegitter vorsichtig nach oben und aus der vorderen Aufhängung.	
Schritt 3	Ziehen Sie das Eihängegitter vorne von der Seitenwand weg.	
Schritt 4	Ziehen Sie die Gitter aus der hinteren Aufhängung heraus.	
Setzen Sie die Eihängegitter in umgekehrter Reihenfolge ein.		

11.3 Benutzung: Pyrolytische Reinigung



Reinigen Sie den Backofen mit Pyrolytische Reinigung.

	WARNUNG! Es besteht das Risiko von Verbrennungen.
	VORSICHT! Befinden sich weitere Geräte in demselben Küchenmöbel, verwenden Sie diese nicht während dieser Funktion. Andernfalls kann der Backofen beschädigt werden.

Vor dem Pyrolytische Reinigung:

Schalten Sie den Backofen aus und warten Sie, bis er abgekühlt ist.	Entfernen Sie alle Zubehörteile aus dem Backofen.	Reinigen Sie den Backofenboden und die innere Türglasscheibe mit warmem Wasser, einem weichen Tuch und einem milden Reinigungsmittel.
---------------------------------------------------------------------	---------------------------------------------------	---------------------------------------------------------------------------------------------------------------------------------------

Füllen Sie den Wassertank nicht während der Reinigung. Der Reinigungsvorgang würde neu starten.

Schritt 1	Schalten Sie den Backofen ein.	
Schritt 2	Drücken Sie:  /Reinigung.	
Schritt 3	Setzen Sie das Backblech in die erste Einschubebene ein, um das Wasser aus dem Wassertank aufzufangen. OK - Drücken, um die Entleerung des Wassertanks zu starten.	
Schritt 4	Entfernen Sie das Backblech und die herausnehmbaren Einhängegeritter, wenn das Entleeren des Tanks beendet ist. Wischen Sie den Garraum und die innere Glasscheibe mit einem weichen Tuch ab. Drücken Sie: OK.	
Schritt 5	Wählen Sie den Reinigungsmodus.	
Option	Reinigungsmodus	Dauer
Pyrolytische Reinigung, kurz	Leichte Reinigung	1 h
Pyrolytische Reinigung, normal	Normale Reinigung	1 h 30 min
Pyrolytische Reinigung, intensiv	Gründliche Reinigung	3 h
<p> Wenn die Reinigung beginnt, wird die Lampe ausgeschaltet, und der Kühlventilator läuft mit einer höheren Drehzahl.</p> <p>STOP - zum vorzeitigen Ausschalten des Reinigungsvorgangs drücken.</p> <p>Verwenden Sie den Backofen nicht, bevor das Türverriegelungssymbol im Display erlischt.</p>		

REINIGUNG UND PFLEGE

Nach Abschluss der Reinigung:

Schalten Sie den Backofen aus und warten Sie, bis er abgekühlt ist.	Reinigen Sie den Garraum mit einem weichen Tuch.	Entfernen Sie die Rückstände vom Garraumboden.
---------------------------------------------------------------------	--------------------------------------------------	------------------------------------------------

11.4 Erinnerungsfunktion Reinigen

Wenn die Erinnerung erscheint, wird die Reinigung empfohlen.

Verwenden Sie die Funktion: Pyrolytische Reinigung.

11.5 Benutzung: Entkalkung

Bevor Sie beginnen:

Schalten Sie den Backofen aus und warten Sie, bis er abgekühlt ist.	Entfernen Sie alle Zubehöreile.	Vergewissern Sie sich, dass der Wassertank leer ist.
---------------------------------------------------------------------	---------------------------------	------------------------------------------------------

Dauer des ersten Teils: etwa 100 Min

Schritt 1	Setzen Sie die Auflauffanne in die erste Einschubebene ein.
Schritt 2	Füllen Sie 250 ml Entkalker in den Wassertank.
Schritt 3	Füllen Sie den Wassertank erneut bis zum Höchststand mit Wasser auf, bis der Signalton ertönt oder das Display eine Meldung anzeigt.
Schritt 4	Wählen Sie: Menü / Reinigung.
Schritt 5	Aktivieren Sie die Funktion und befolgen Sie die Hinweise im Display. Der erste Teil des Entkalkungsvorgangs startet.
Schritt 6	Leeren Sie nach Abschluss des ersten Teils die Auflauffanne und setzen Sie sie wieder in die erste Einschubebene ein.

Dauer des zweiten Teils: etwa 35 Min

Schritt 7	Füllen Sie den Wassertank erneut bis zum Höchststand mit Wasser auf, bis der Signalton ertönt oder das Display eine Meldung anzeigt.
Schritt 8	Entfernen Sie die Auflaufpfanne, wenn die Funktion beendet ist.
 Die Backofenlampe ist während der Funktionsausführung aus.	

Nach Abschluss der Entkalkung:		
Schalten Sie den Backofen aus.	Wenn der Backofen abgekühlt ist, trocknen Sie den Garraum mit einem weichen Tuch.	Lassen Sie die Backofentür geöffnet und warten Sie, bis der Garraum trocken ist.
 Sollten nach der Entkalkung noch Kalkrückstände im Backofen vorhanden sein, fordert das Display Sie zur Wiederholung des Vorgangs auf.		

11.6 Entkalkungserinnerungen

Zwei Erinnerungsfunktionen fordern Sie auf den Backofen zu entkalken. Die Entkalkungserinnerung können Sie nicht ausschalten.

Typ	Beschreibung
Sanfte Erinnerung	Empfiehl die Entkalkung des Backofens.
Dringende Erinnerung	Zwingt Sie die Entkalkung des Backofens durchzuführen. Entkalken Sie den Backofen trotz der dringenden Erinnerung nicht, können Sie die Dampffunktionen nicht verwenden.

11.7 Benutzung: Spülen

Bevor Sie beginnen:	
Schalten Sie den Backofen aus und warten Sie, bis er abgekühlt ist.	Entfernen Sie alle Zubehörteile.

Schritt 1	Setzen Sie die Auflaufpfanne in die erste Einschubebene ein.
Schritt 2	Füllen Sie den Wassertank bis zur Höchstgrenze mit Wasser, bis der Signalton ertönt oder das Display eine Meldung anzeigt.

REINIGUNG UND PFLEGE

Schritt 3	Wählen Sie: Menü / Reinigung / Spülen. Dauer: ca. 30 Min
Schritt 4	Aktivieren Sie die Funktion und befolgen Sie die Hinweise im Display.
Schritt 5	Entfernen Sie die Auflauffanne, wenn die Funktion beendet ist.
 Die Backofenlampe ist während der Funktionsausführung aus.	

11.8 Benutzung: Entleeren des Wassertanks



Verwenden Sie diese Funktion nach Kochen mit einer Dampfheizfunktion, um Restwasser aus dem Wassertank zu entfernen.

Bevor Sie beginnen:	
Schalten Sie den Backofen aus und warten Sie, bis er abgekühlt ist.	Entfernen Sie alle Zubehörteile.

Schritt 1	Setzen Sie die Auflauffanne in die erste Einschubebene ein.
Schritt 2	Wählen Sie: Menü / Reinigung / Entleeren des Wassertanks. Dauer: 6 Min
Schritt 3	Aktivieren Sie die Funktion und befolgen Sie die Hinweise im Display.
Schritt 4	Entfernen Sie die Auflauffanne, wenn die Funktion beendet ist.
 Die Backofenlampe ist während der Funktionsausführung aus.	

11.9 Aus- und Einbau: Tür

Sie können die Tür und inneren Glasscheiben zur Reinigung entfernen. Die Anzahl der Glasscheiben unterscheidet sich je nach Modell.

 WARNUNG! Die Tür ist schwer.
 VORSICHT! Behandeln Sie das Glas vorsichtig, insbesondere an den Kanten der vorderen Scheibe. Das Glas kann zerbrechen.

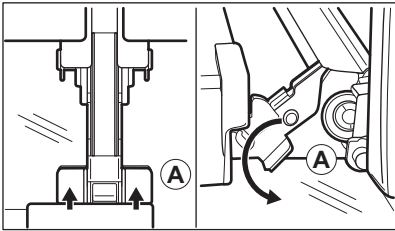
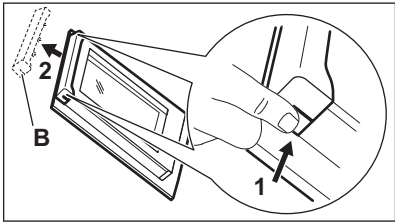
Schritt 1	Öffnen Sie die Tür vollständig.	
Schritt 2	Heben Sie die Klemmhebel (A) an beiden Türscharnieren an und drücken Sie auf sie.	
Schritt 3	Schließen Sie die Backofentür bis zur ersten Öffnungsstellung (in einem Winkel von ca. 70°). Fassen Sie die Tür mit beiden Händen seitlich an und ziehen Sie sie schräg nach oben vom Backofen weg. Legen Sie die Tür mit der Außenseite nach unten auf ein weiches Tuch und eine stabile Fläche.	
Schritt 4	Fassen Sie die Türabdeckung (B) an der Oberkante der Tür an beiden Seiten an. Drücken Sie sie nach innen, um den Klippverschluss zu lösen.	
Schritt 5	Ziehen Sie die Türabdeckung nach vorn, um sie abzunehmen.	
Schritt 6	Fassen Sie die Glasscheiben der Tür nacheinander am oberen Rand an und ziehen Sie sie nach oben aus den Führungen.	
Schritt 7	Reinigen Sie die Glasscheibe mit Wasser und Spülmittel. Trocknen Sie die Glasscheibe sorgfältig ab. Reinigen Sie die Glasscheiben nicht im Geschirrspüler.	
Schritt 8	Führen Sie nach der Reinigung die obigen Schritte in umgekehrter Reihenfolge durch.	
Schritt 9	Setzen Sie zuerst die kleinere Scheibe ein, dann die größere Scheibe und die Tür.	

11.10 Austausch: Lampe

**WARNUNG!**

Stromschlaggefahr.
Die Lampe kann heiß sein.

Bevor Sie die Lampe austauschen:

Schritt 1	Schritt 2	Schritt 3
Schalten Sie den Backofen aus. Warten Sie, bis der Ofen kalt ist.	Trennen Sie den Ofen von der Netzversorgung.	Breiten Sie ein Tuch auf dem Garraumboden aus.

Obere Lampe

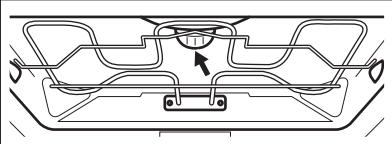
Schritt 1	Drehen Sie die Glasabdeckung und nehmen Sie sie ab.	
Schritt 2	Entfernen Sie den Metallring und reinigen Sie die Glasabdeckung.	
Schritt 3	Ersetzen Sie die Lampe durch eine geeignete, bis 300 °C hitzebeständige Lampe.	
Schritt 4	Stecken Sie den Metallring auf die Glasabdeckung und bringen Sie sie an.	

Seitenlampe

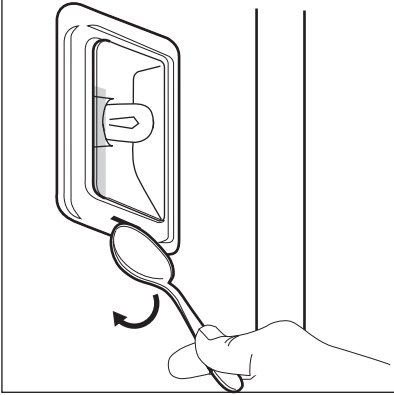
Schritt 1	Entfernen Sie die linke Regalstütze, um an die Lampe zu gelangen.	
Schritt 2	Verwenden Sie einen schmalen, stumpfen Gegenstand (z. B. einen Teelöffel), um die Glasabdeckung zu entfernen.	
Schritt 3	Reinigen Sie die Glasabdeckung.	
Schritt 4	Ersetzen Sie die Lampe durch eine geeignete, bis 300 °C hitzebeständige Lampe.	
Schritt 5	Bringen Sie die Glasabdeckung an.	
Schritt 6	Montieren Sie die linke Regalstütze.	



12. FEHLERSUCHE









WARNUNG!

Siehe Kapitel Sicherheitshinweise.

12.1 Was zu tun ist, wenn ...

 Das Gerät schaltet sich nicht ein oder heizt nicht auf	
 Mögliche Ursache	 Problemebehebung
Das Gerät ist nicht oder nicht ordnungsgemäß an die Spannungsversorgung angeschlossen.	Prüfen Sie, ob das Gerät ordnungsgemäß an die Spannungsversorgung angeschlossen ist.
Die Uhrzeit ist nicht eingestellt.	Stellen Sie die Uhr ein. Einzelheiten finden Sie im Uhrfunktionen „Einstellungen:“ Uhrfunktionen.
Die Tür ist nicht richtig geschlossen.	Schließen Sie die Tür vollständig.



 Das Gerät schaltet sich nicht ein oder heizt nicht auf	
 Mögliche Ursache	 Problembehebung
Die Sicherung ist durchgebrannt.	Vergewissern Sie sich, dass die Sicherung der Grund für die Störung ist. Wenn das Problem erneut auftritt, wenden Sie sich an einen qualifizierten Elektriker.
Am Gerät Kindersicherung eingeschaltet.	Siehe Kapitel „Menü“, Untermenü: Optionen.



 Komponenten	
 Beschreibung	 Problembehebung
Die Lampe ist durchgebrannt.	Ersetzen Sie die Lampe, Einzelheiten finden Sie im Kapitel „Pflege und Reinigung“, Austausch: Lampe.

Die Reinigung wird immer durch einen Stromausfall unterbrochen. Wiederholen Sie die Reinigung, wenn diese von einem Stromausfall unterbrochen wurde.

12.2 Handhabung: Fehlercodes

Im Falle eines Softwarefehlers zeigt das Display eine Fehlermeldung an. Dieser Abschnitt enthält eine Liste mit Störungen, die Sie selbst beheben können.

 Code und Beschreibung	 Problembehebung
C2 – der Temperatursensor befindet sich im Innern des Geräts während Pyrolytische Reinigung.	Nehmen Sie den Temperatursensor.
C3 – Die Tür ist nicht richtig geschlossen während Pyrolytische Reinigung.	Schließen Sie die Tür.
F111 – Temperatursensor wurde nicht richtig in die Steckdose eingesteckt.	Stecken Sie Temperatursensor vollständig in die Steckdose.

 Code und Beschreibung	 Problembesehung
F240, F439 - Die Sensorfelder des Displays funktionieren nicht einwandfrei.	Reinigen Sie die Displayoberfläche. Stellen Sie sicher, dass sich kein Schmutz auf den Sensorfeldern befindet.
F908 – Das Gerätesystem kann sich nicht mit dem Bedienfeld verbinden.	Schalten Sie das Gerät aus und wieder ein.

12.3 Service-Daten

Wenn Sie das Problem nicht selbst lösen können, wenden Sie sich an Ihren Händler oder einen autorisierten Kundendienst.

Die vom Kundendienst benötigten Daten finden Sie auf dem Typenschild. Das Typenschild befindet sich am vorderen Rahmen des Garraums des Geräts. Entfernen Sie das Typenschild nicht vom Garraum.

Wir empfehlen Ihnen, die Daten hier zu notieren:	
Modell (MOD.):
Produktnummer (PNC)
Seriennummer (S.N.)

13. ENERGIEEFFIZIENZ

13.1 Produktinformation und Produktinformationsblatt

Name des Lieferanten	AEG
Modellbezeichnung	BSE77280M 944188685 BSE77228BM 944188655 BSK772280M 944188643 BSS772280B 944188644
Energieeffizienzindex	61.2
Energieeffizienzklasse	A++
Energieverbrauch mit einer Standardbeladung, konventioneller Modus	1.09 kWh/Programm

Energieverbrauch mit einer Standardbelastung, Umluft-Modus	0.52 kWh/Programm	
Anzahl der Garräume	1	
Wärmequelle	Strom	
Volumen	71 l	
Art des Backofens	Eingebauter Backofen	
Masse	BSE772280M	36.0 kg
	BSE77228BM	36.0 kg
	BSK772280M	36.0 kg
	BSS772280B	36.0 kg

IEC/EN 60350-1 – Elektrische Kochgeräte für den Hausgebrauch – Teil 1: Stufen, Backöfen, Dampföfen und Grills – Methoden zur Leistungsmessung.

13.2 Energiesparen



Das Gerät verfügt über Funktionen, mit deren Hilfe Sie beim täglichen Kochen Energie sparen können.

Stellen Sie sicher, dass die Gerätetür geschlossen ist, wenn das Gerät in Betrieb ist. Die Gerätetür darf während des Garvorgangs nicht zu oft geöffnet werden. Halten Sie die Türdichtung sauber und stellen Sie sicher, dass sie sich fest in der richtigen Position befindet. Verwenden Sie Kochgeschirr aus Metall, um mehr Energie zu sparen.

Heizen Sie, wenn möglich, das Gerät vor dem Garvorgang nicht vor.

Wenn Sie mehrere Speisen gleichzeitig zubereiten, halten Sie die Unterbrechungen beim Backen so kurz wie möglich.

Garen mit Heißluft

Nutzen Sie, wenn möglich, die Garfunktionen mit Heißluft, um Energie zu sparen.

Restwärme

Wenn ein Programm mit Dauer aktiviert ist und die Kochzeit länger als 30 Minuten ist, schalten sich die Heizelemente bei einigen Gerätefunktionen automatisch früher aus.

Ventilator und Lampe funktionieren weiter. Sobald Sie das Gerät ausschalten, wird im Display die Restwärme angezeigt. Die Restwärme kann zum Warmhalten von Speisen genutzt werden. Beträgt die Garzeit mehr als 30 Minuten, reduzieren Sie die Gerätetemperatur mindestens 3 - 10 Min. vor Ablauf des Garvorgangs. Durch die Restwärme im Gerät wird der Garvorgang fortgesetzt.

Nutzen Sie die Restwärme, um andere Speisen aufzuwärmen.

Warmhalten von Speisen

Wählen Sie die niedrigste Temperatureinstellung, wenn Sie die Restwärme zum Warmhalten von Speisen nutzen möchten. Die Restwärmeanzeige oder Temperatur werden auf dem Display angezeigt.

Garen bei ausgeschalteter Backofenbeleuchtung

Schalten Sie die Lampe während des Garvorgangs aus. Schalten Sie sie nur ein, wenn Sie sie benötigen.

Feuchte Umluft

Diese Funktion soll während des Garvorgangs Energie sparen.

Bei Verwendung dieser Funktion schaltet sich die Lampe automatisch nach 30 Sekunden aus. Sie können die Lampe wieder einschalten, aber dadurch werden die erwarteten Energieeinsparungen reduziert.

14. MENÜSTRUKTUR

14.1 Menü

Menüpunkt		Anwendung
Koch-Assistent		Liste der automatischen Programme.
Reinigung		Liste der Reinigungsprogramme.
Favoriten		Liste der bevorzugten Einstellungen.
Optionen		Konfigurieren des Geräts.
Einstellungen	Setup	Konfigurieren des Geräts.
	Service	Anzeige der Softwareversion und Konfiguration.

14.2 Untermenü für: Reinigung

Untermenü	Verwendung
Entleeren des Wassertanks	Programm zum Entleeren des Restwassers aus dem Wassertank nach Verwendung der Dampffunktionen.
Pyrolytische Reinigung, kurz	Dauer: 1 h.
Pyrolytische Reinigung, normal	Dauer: 1 h 30 min.
Pyrolytische Reinigung, intensiv	Dauer: 3 h.

Untermenü	Verwendung
Entkalkung	Entkalkungsprogramm zum Entfernen von Kalkrückständen aus dem Dampfgenerator-Kreislauf.
Spülen	Programm zum Spülen und Reinigen des Dampfgenerator-Kreislaufs nach häufiger Verwendung der Dampffunktionen.

14.3 Untermenü für: Optionen

Untermenü	Verwendung
Backofenbeleuchtung	Ein- und Ausschalten der Beleuchtung.
Kindersicherung	Verhindert ein versehentliches Einschalten des Geräts. Wenn die Option aktiviert ist, erscheint Kindersicherung auf dem Display, wenn Sie das Gerät einschalten. Um das Gerät verwenden zu können, wählen Sie die Buchstaben des Codes in alphabetischer Reihenfolge. Wenn die Option aktiviert und das Gerät ausgeschaltet ist, ist die Gerätetür verriegelt. Der Zugriff auf den Timer, die Fernsteuerung und die Lampe ist möglich, wenn die Option aktiviert ist.
Schnellaufheizung	Verringert die Aufheizzeit. Es ist nur für einige Gerätefunktionen verfügbar.
Zeitanzeige	Ein- und Ausschalten der Uhr.
Digitale Uhrzeitanzeige	Ändern des Formats der angezeigten Uhrzeit.

14.4 Untermenü für: Setup

Untermenü	Beschreibung
Sprache	Legt die Sprache des Geräts fest.
Helligkeit	Auswahl der Helligkeit.
Tastentöne	Ein- und Ausschalten der Tastentöne der Sensorfelder. Es ist nicht möglich, den Signalton für Folgendes stummzuschalten: ①.

Untermenü	Beschreibung
Lautstärke	Einstellen der Lautstärke der Tastentöne und Signale.
Wasserhärte	Einstellen der Wasserhärte.
Uhrzeit	Einstellen der aktuellen Uhrzeit und des Datums.

14.5 Untermenü von: Service

Untermenü	Bezeichnung
DEMO	Aktivierungs-/Deaktivierungscode: 2468
Softwareversion	Informationen zur Softwareversion.
Gerät auf Werkseinstellungen zurücksetzen	Wiederherstellung der Werkseinstellungen.

15. DAS IST GANZ EINFACH!



Vor der ersten Inbetriebnahme müssen Sie folgende Einstellungen vornehmen:



Sprache	Helligkeit	Tastentöne	Lautstärke	Wasserhärte	Uhrzeit
---------	------------	------------	------------	-------------	---------

Erste Schritte

Schnellstart	Schritt 1	Schritt 2	Schritt 3
Schalten Sie das Gerät ein und garen Sie mit der voreingestellten Temperatur und Dauer der Funktion.	Halten Sie gedrückt: ①.	<input type="checkbox"/> ... - Wählen Sie die gewünschte Funktion.	Drücken Sie: START .
	① – Gedrückt halten, bis sich das Gerät ausschaltet.		
Schnellabschaltung	Schalten Sie das Gerät jederzeit aus, unabhängig von der Anzeige oder Meldung.		

DAS IST GANZ EINFACH!

Beginnen Sie mit dem Kochen				
Schritt 1	Schritt 2	Schritt 3	Schritt 4	Schritt 5
 – Drücken, um das Gerät einzuschalten.	 ... – Wählen Sie die Ofenfunktion.	 – Einstellung der Temperatur.	OK – Zur Bestätigung drücken.	START – Zum Starten des Garvorgangs drücken.

Erfahren Sie, wie Sie schnell garen.				
Verwenden Sie Automatikprogramme, um eine Speise schnell mit den Voreinstellungen zuzubereiten:				
Koch-Assistent	Schritt 1	Schritt 2	Schritt 3	Schritt 4
	Drücken Sie: 	Drücken Sie: 	Drücken Sie: 	Wählen Sie die Speise.

Verwenden Sie die Schnellfunktionen zur Einstellung der Gardauer	
10% Finish Assist Verwenden Sie 10 % Finish Assist, um eine Zeitverlängerung festzulegen, wenn 10 % der Garzeit verbleiben.	Drücken Sie zur Verlängerung der Garzeit +1Min.

16. INFORMATIONEN ZUR ENTSORGUNG

Ihre Pflichten als Endnutzer



Dieses Elektro- bzw. Elektronikgerät ist mit einer durchgestrichenen Abfalltonne auf Rädern gekennzeichnet. Das Gerät darf deshalb nur getrennt vom unsortierten Siedlungsabfall gesammelt und zurückgenommen werden, es darf also nicht in den Hausmüll gegeben werden. Das Gerät kann z. B. bei einer kommunalen Sammelstelle oder ggf. bei einem Vertreiber (siehe zu deren Rücknahmepflichten unten) abgegeben werden. Das gilt auch für alle Bauteile, Unterbaugruppen und Verbrauchsmaterialien des zu entsorgenden Altgeräts. Bevor das Altgerät entsorgt werden darf, müssen alle Altbatterien und Altkumulatoren vom Altgerät getrennt werden, die nicht vom Altgerät umschlossen sind. Das gleiche gilt für Lampen,

die zerstörungsfrei aus dem Altgerät entnommen werden können. Der Endnutzer ist zudem selbst dafür verantwortlich, personenbezogene Daten auf dem Altgerät zu löschen.

Hinweise zum Recycling

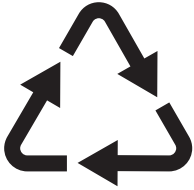

Helfen Sie mit, alle Materialien zu recyceln, die mit diesem Symbol gekennzeichnet sind. Entsorgen Sie solche Materialien, insbesondere Verpackungen, nicht im Hausmüll sondern über die bereitgestellten Recyclingbehälter oder die entsprechenden örtlichen Sammelsysteme. Recyceln Sie zum Umwelt- und Gesundheitsschutz auch elektrische und elektronische Geräte.

Rücknahmepflichten der Verreiber in Deutschland

Wer auf mindestens 400 m² Verkaufsfläche Elektro- und Elektronikgeräte vertreibt oder sonst geschäftlich an Endnutzer abgibt, ist verpflichtet, bei Abgabe eines neuen Geräts ein Altgerät des Endnutzers der gleichen Geräteart, das im Wesentlichen die gleichen Funktionen wie das neue Gerät erfüllt, am Ort der Abgabe oder in unmittelbarer Nähe hierzu unentgeltlich zurückzunehmen. Das gilt auch für Verreiber von Lebensmitteln mit einer Gesamtverkaufsfläche von mindestens 800 m², die mehrmals im Kalenderjahr oder dauerhaft Elektro- und Elektronikgeräte anbieten und auf dem Markt bereitstellen. Solche Verreiber müssen zudem auf Verlangen des Endnutzers Altgeräte, die in keiner äußeren Abmessung größer als 25 cm sind (kleine Elektrogeräte), im Einzelhandelsgeschäft oder in unmittelbarer Nähe hierzu unentgeltlich zurückzunehmen; die Rücknahme darf in diesem Fall nicht an den Kauf eines Elektro- oder Elektronikgerätes geknüpft, kann aber auf drei Altgeräte pro Geräteart beschränkt werden.

Ort der Abgabe ist auch der private Haushalt, wenn das neue Elektro- oder Elektronikgerät dorthin geliefert wird; in diesem Fall ist die Abholung des Altgerätes für den Endnutzer kostenlos.

Die vorstehenden Pflichten gelten auch für den Vertrieb unter Verwendung von Fernkommunikationsmitteln, wenn die Verreiber Lager- und Versandflächen für Elektro- und Elektronikgeräte bzw. Gesamtlager- und -versandflächen für Lebensmittel vorhalten, die den oben genannten Verkaufsflächen entsprechen. Die unentgeltliche Abholung von Elektro- und Elektronikgeräten ist dann aber auf Wärmeüberträger (z. B. Kühlschrank), Bildschirme, Monitore und Geräte, die Bildschirme mit einer Oberfläche von mehr als 100 cm² enthalten, und Geräte beschränkt, bei denen mindestens eine der äußeren Abmessungen mehr als 50 cm beträgt. Für alle übrigen Elektro- und Elektronikgeräte muss der Verreiber geeignete Rückgabemöglichkeiten in zumutbarer Entfernung zum jeweiligen Endnutzer gewährleisten; das gilt auch für kleine Elektrogeräte (s.o.), die der Endnutzer zurückgeben will, ohne ein neues Gerät zu kaufen.

Rücknahmepflichten von Verreibern und andere Möglichkeiten der Entsorgung von Elektro- und Elektronikgeräten in der Region Wallonien

Verreiber, die Elektro- und Elektronikgeräte verkaufen, sind verpflichtet, bei der Lieferung von Neugeräten Altgeräte desselben Typs, die im Wesentlichen die gleichen Funktionen wie die Neugeräte erfüllen, kostenlos vom Endverbraucher zurückzunehmen. Dies gilt auch bei der Lieferung von neuen Elektro- und Elektronikgeräten oder beim Fernabsatz.

Darüber hinaus ist jeder, der Elektro- und Elektronikgeräte auf einer Verkaufsfläche von mindestens 400 m² verkauft, verpflichtet, Altgeräte, die in keiner äußeren Abmessung größer als 25 cm sind (Elektrokleingeräte), im Ladengeschäft oder in unmittelbarer Nähe kostenlos zurückzunehmen; die Rücknahme darf in diesem Fall nicht vom Kauf eines Elektro- oder Elektronikgerätes abhängig gemacht werden.

DAS IST GANZ EINFACH!

Die Rücknahme von Elektro- und Elektronikgeräten kann auch auf Containerplätzen oder zugelassenen Recyclinghöfen erfolgen. Für weitere Informationen wenden Sie sich bitte an Ihre Gemeindeverwaltung.

PER RISULTATI PERFETTI

Grazie per aver scelto di acquistare questo prodotto AEG. Lo abbiamo creato per fornirvi prestazioni impeccabili per molti anni, grazie a tecnologie innovative che vi semplificheranno la vita - funzioni che non troverete sulle normali apparecchiature. Vi invitiamo di dedicare qualche minuto alla lettura per sapere come trarre il massimo dal vostro elettrodomestico.

Visitate il nostro sito web per:



Ricevere consigli, scaricare i nostri opuscoli, eliminare eventuali anomalie, ottenere informazioni sull'assistenza e la riparazione:

www.aeg.com/support



Per registrare il vostro prodotto e ricevere un servizio migliore:

www.registreaeg.com



Acquistare accessori, materiali di consumo e ricambi originali per la vostra apparecchiatura:

www.aeg.com/shop

ASSISTENZA CLIENTI E ASSISTENZA TECNICA

Consigliamo sempre l'impiego di ricambi originali.

Quando si contatta il nostro Centro di Assistenza Autorizzato, accertarsi di avere a disposizione i dati seguenti: Modello, numero dell'apparecchio (PNC), numero di serie.

Le informazioni sono riportate sulla targhetta identificativa.

 Avvertenza/Attenzione - Importanti Informazioni per la sicurezza

 Informazioni generali e suggerimenti

 Informazioni ambientali

Con riserva di modifiche.

INDICE

1. INFORMAZIONI DI SICUREZZA.....	212	3.2 Accessori.....	219
1.1 Sicurezza di bambini e persone vulnerabili.....	212	4. PANNELLO DEI COMANDI.....	220
1.2 Avvertenze di sicurezza generali.....	213	4.1 Panoramica del pannello di controllo.....	220
2. ISTRUZIONI DI SICUREZZA.....	214	4.2 Display.....	221
2.1 Installazione.....	214	5. PRIMA DEL PRIMO UTILIZZO.....	222
2.2 Collegamento elettrico.....	216	5.1 Pulizia iniziale	222
2.3 Utilizzo:.....	216	5.2 Prima connessione.....	222
2.4 Pulizia e cura.....	217	5.3 Preriscaldamento iniziale.....	222
2.5 Pulizia per pirolisi.....	217	5.4 Come impostare: Durezza dell'acqua.....	222
2.6 Cottura a vapore.....	218	6. UTILIZZO QUOTIDIANO.....	223
2.7 Illuminazione interna.....	218	6.1 Come impostare: Funzioni cottura.....	224
2.8 Assistenza.....	218	6.2 Come impostare: Funzione cottura a vapore.....	224
2.9 Smaltimento.....	219		
3. DESCRIZIONE DEL PRODOTTO.....	219		
3.1 Panoramica generale.....	219		

6.3	Come impostare: Cottura guidata	225	11.4	Promemoria Pulizia	242
6.4	Funzioni cottura	226	11.5	Istruzioni d'uso: Decalcificazione	242
6.5	Note su: Cottura ventilata umida	228	11.6	Promemoria trattamento anticalcare	243
7	FUNZIONI DEL TIMER	229	11.7	Istruzioni d'uso: Risciacquo	243
7.1	Descrizione funzioni orologio	229	11.8	Modalità d'uso: Svuotamento serbatoio	244
7.2	Come impostare: Funzioni Orologio	229	11.9	Procedura di rimozione e installazione: Porta	245
8	UTILIZZO DEGLI ACCESSORI	232	11.10	Come sostituire: Lampadina	246
8.1	Inserimento di accessori	232	12	RISOLUZIONE DEI PROBLEMI	247
8.2	Termosonda	233	12.1	Cosa fare se	248
8.3	Istruzioni d'uso: Termosonda	233	12.2	Come gestire: Codici di errore	248
9	FUNZIONI AGGIUNTIVE	234	12.3	Dati dell'Assistenza	249
9.1	Come salvare: Preferiti	234	13	EFFICIENZA ENERGETICA	249
9.2	Blocco tasti	235	13.1	Informazioni sul prodotto e scheda informativa sul prodotto	249
9.3	Spegnimento automatico	235	13.2	Risparmio energetico	250
9.4	Ventola di raffreddamento	236	14	STRUTTURA DEL MENU	251
10	CONSIGLI E SUGGERIMENTI UTILI	236	14.1	Menu	251
10.1	Consigli di cottura	236	14.2	Sottomenu per: Pulizia	251
10.2	Cottura ventilata umida	236	14.3	Sottomenu per: Opzioni	252
10.3	Cottura ventilata umida - accessori consigliati	237	14.4	Sottomenu per: Configurazione	252
10.4	Tabelle di cottura per gli istituti di test	238	14.5	Sottomenu per: Assistenza tecnica	253
11	PULIZIA E CURA	239	15	È SEMPLICE!	253
11.1	Note sulla pulizia	239	16	CONSIDERAZIONI SULL'AMBIENTE	254
11.2	Come rimuovere: Supporti del ripiano	240			
11.3	Istruzioni d'uso: Pulizia per pirolisi	240			

1. INFORMAZIONI DI SICUREZZA

Leggere attentamente le istruzioni fornite prima di installare e utilizzare l'apparecchiatura. I produttori non sono responsabili di eventuali lesioni o danni derivanti da un'installazione o un uso scorretti. Conservare sempre le istruzioni in un luogo sicuro e accessibile per poterle consultare in futuro.

1.1 Sicurezza di bambini e persone vulnerabili

- Quest'apparecchiatura può essere usata da bambini a partire da 8 anni di età e da adulti con capacità fisiche,

sensoriali o mentali limitate o con scarsa esperienza e conoscenza sull'uso dell'apparecchiatura, solamente se sorvegliati o se istruiti relativamente all'utilizzo in sicurezza dell'apparecchiatura e se hanno compreso i rischi coinvolti. I bambini che hanno meno di 8 anni e le persone con disabilità diffuse e complesse vanno tenuti lontani dall'elettrodomestico, a meno che non vi sia una supervisione continua.

- I bambini devono essere sorvegliati per assicurarsi che non giochino con l'apparecchiatura.
- Tenere gli imballaggi lontano dai bambini e smaltirli in modo adeguato.
- **AVVERTENZA:** L'elettrodomestico e le parti accessibili si riscaldano molto durante l'uso. Tenere i bambini e gli animali domestici lontani dall'apparecchiatura durante l'uso e durante il raffreddamento.
- Se l'elettrodomestico ha un dispositivo di sicurezza per i bambini sarà opportuno attivarlo.
- I bambini non devono eseguire interventi di pulizia e manutenzione sull'elettrodomestico senza essere supervisionati.

1.2 Avvertenze di sicurezza generali

- L'apparecchiatura è destinata solo alla cottura.
- Quest'apparecchiatura è progettata per un uso domestico singolo in un ambiente interno.
- Quest'apparecchiatura può essere utilizzata in uffici, camere d'albergo, camere di bed & breakfast, alloggi in agriturismo e altre sistemazioni simili in cui tale utilizzo non superi i livelli di utilizzo domestico (medi).
- L'installazione dell'apparecchiatura e la sostituzione dei cavideve essere effettuata unicamente da personale qualificato.
- Non utilizzare l'apparecchiatura prima di installarla nella struttura a incasso.

ISTRUZIONI DI SICUREZZA

- Prima di ogni operazione di manutenzione, scollegare l'apparecchiatura dall'alimentazione elettrica.
- Se il cavo di alimentazione è danneggiato, deve essere sostituito dal produttore, da un centro di assistenza tecnica autorizzato o da una persona qualificata per evitare situazioni di pericolo elettrico.
- **AVVERTENZA:** Assicurarsi che l'elettrodomestico sia spento prima di sostituire la lampadina per evitare la possibilità di scosse elettriche.
- **AVVERTENZA:** L'elettrodomestico e le parti accessibili si riscaldano molto durante l'uso. Prestare attenzione a non toccare le resistenze o la superficie della cavità dell'apparecchiatura.
- Utilizzare sempre guanti da forno per rimuovere o inserire accessori o pirofile.
- Usare esclusivamente la termosonda (sensore temperatura al centro) consigliata per questa apparecchiatura.
- Per rimuovere i supporti del ripiano, tirare prima la parte anteriore del supporto del ripiano e poi l'estremità posteriore lontano dalle pareti laterali. Installare i supporti ripiani seguendo al contrario la procedura indicata.
- Non utilizzare vaporelle per pulire l'elettrodomestico.
- Non utilizzare detergenti abrasivi o raschietti di metallo per pulire il vetro dello sportello per non rigare la superficie e causare la rottura del vetro.
- Prima della pulizia per pirolisi rimuovere gli accessori e i depositi/le fuoriuscite eccessivi dalla cavità dell'apparecchiatura.

2. ISTRUZIONI DI SICUREZZA

2.1 Installazione

**AVVERTENZA!**

L'installazione dell'apparecchiatura deve essere eseguita da personale qualificato.

- Rimuovere tutti i materiali di imballaggio.
- Non installare o utilizzare l'apparecchiatura se è danneggiata.

ISTRUZIONI DI SICUREZZA

- Attenersi alle istruzioni fornite insieme all'apparecchiatura.
- Prestare sempre attenzione in fase di spostamento dell'apparecchiatura, dato che è pesante. Usare sempre i guanti di sicurezza e le calzature adeguate.
- Non tirare l'apparecchiatura per la maniglia.
- Installare l'apparecchiatura in un luogo sicuro e idoneo che soddisfi i requisiti di installazione.
- È necessario rispettare la distanza minima dalle altre apparecchiature.
- Prima di montare l'apparecchiatura controllare che la porta dell'apparecchio si apra senza limitazioni.
- L'apparecchiatura è dotata di un sistema di raffreddamento elettrico. Quest'ultimo funziona a corrente elettrica.
- L'unità a incasso deve soddisfare i requisiti di stabilità DIN 68930.

Altezza minima del mobiletto (mobiletto sotto all'altezza minima del piano di lavoro)	578 (600) mm
Larghezza del mobiletto	560 mm
Profondità del mobiletto	550 (550) mm
Altezza della parte anteriore dell'apparecchiatura	594 mm
Altezza della parte posteriore dell'apparecchiatura	576 mm
Larghezza della parte anteriore dell'apparecchiatura	595 mm
Larghezza della parte posteriore dell'apparecchiatura	559 mm
Profondità dell'apparecchiatura	567 mm
Profondità di incasso dell'apparecchiatura	546 mm
Profondità con porta aperta	1027 mm
Dimensioni minime dell'apertura di ventilazione. Apertura collocata sul lato posteriore inferiore	560x20 mm
Lunghezza del cavo di alimentazione. Il cavo è collocato nell'angolo destro del lato posteriore	1500 mm
Viti di montaggio	4x25 mm

2.2 Collegamento elettrico



AVVERTENZA!

Rischio di incendio e scossa elettrica.

- Tutti i collegamenti elettrici devono essere realizzati da un elettricista qualificato.
- L'apparecchiatura deve disporre di una messa a terra.
- Verificare che i parametri sulla targhetta siano compatibili con le indicazioni elettriche dell'alimentazione.
- Utilizzare sempre una presa elettrica con contatto di protezione correttamente installata.
- Non utilizzare prese multiple e prolunghe.
- Accertarsi di non danneggiare la spina e il cavo. Qualora il cavo elettrico debba essere sostituito, l'intervento dovrà essere effettuato dal nostro Centro di Assistenza autorizzato.
- Evitare che i cavi entrino a contatto o si trovino vicino alla porta dell'apparecchiatura o sulla nicchia sotto all'apparecchiatura, in particolare quando il dispositivo è in funzione o la porta è calda.
- I dispositivi di protezione da scosse elettriche devono essere fissati in modo tale da non poter essere disattivati senza l'uso di attrezzi.
- Inserire la spina di alimentazione nella presa solo al termine dell'installazione. Verificare che la spina di alimentazione rimanga accessibile dopo l'installazione.
- Nel caso in cui la spina di corrente sia allentata, non collegarla alla presa.
- Non tirare il cavo di alimentazione per scollegare l'apparecchiatura. Tirare sempre dalla spina.
- Servirsi unicamente di dispositivi di isolamento adeguati: interruttori automatici, fusibili (quelli a tappo devono essere rimossi dal portafusibile), sganciatori per correnti di guasto a terra e relè.
- L'impianto elettrico deve essere dotato di un dispositivo di isolamento che consenta di scollegare l'apparecchiatura dalla presa di corrente a tutti i poli. Il dispositivo di isolamento deve avere una larghezza dell'apertura di contatto non inferiore ai 3 mm.
- Chiudere completamente la porta dell'apparecchiatura prima di collegare spina alla presa elettrica.
- La dotazione standard dell'apparecchiatura al momento della fornitura prevede una spina e un cavo di rete.

2.3 Utilizzo:



AVVERTENZA!

Rischio di lesioni, ustioni, scosse elettriche o esplosioni.

- Non modificare le specifiche tecniche dell'apparecchiatura.
- Assicurarsi che le aperture di ventilazione non siano bloccate.
- Non lasciare l'elettrodomestico incustodito durante il funzionamento.
- Spegnerne l'elettrodomestico dopo ogni utilizzo.
- Prestare attenzione in fase di apertura dello sportello dell'elettrodomestico, quando quest'ultimo è in funzione. Può esservi un rilascio di aria calda.
- Non accendere l'elettrodomestico con le mani bagnate o quando è a contatto con l'acqua.
- Non esercitare pressione sullo sportello aperto.
- Non utilizzare l'elettrodomestico come superficie di lavoro o come superficie di deposito.
- Aprire lo sportello dell'elettrodomestico attentamente. L'utilizzo di ingredienti con alcol può provocare una miscela di alcol e aria.

- Non lasciare scintille o fiamme libere a contatto con l'elettrodomestico quando si apre lo sportello.
- Non appoggiare o tenere liquidi o materiali infiammabili, né oggetti facilmente infiammabili sull'apparecchiatura, al suo interno o nelle immediate vicinanze.

**AVVERTENZA!**

Vi è il rischio di danneggiare l'apparecchiatura.

- Per evitare danni o lo scolorimento dello smalto:
 - Non collocare pirofile o altri oggetti all'interno dell'elettrodomestico direttamente sul fondo.
 - Non collocare la pellicola di alluminio direttamente sul fondo della cavità dell'elettrodomestico.
 - Non versare acqua direttamente all'interno dell'elettrodomestico caldo.
 - Non conservare piatti e alimenti umidi all'interno dell'elettrodomestico dopo aver terminato la cottura.
 - Prestare attenzione in fase di rimozione o installazione degli accessori.
- Lo scolorimento dello smalto o dell'acciaio inox non influisce sulle prestazioni dell'elettrodomestico.
- Usare una leccarda per torte umide. I succhi di frutta causano macchie che possono essere permanenti.
- Eseguire sempre la cottura con lo sportello dell'apparecchiatura chiuso.
- Se l'apparecchiatura si trova dietro a un pannello anteriore (ad es. una porta), assicurarsi che questo non sia mai chiuso quando l'apparecchiatura è in funzione. Calore e umidità possono accumularsi sul retro di un pannello chiuso causando danni all'apparecchiatura, all'alloggiamento o al pavimento. Dopo l'uso non chiudere il pannello dell'armadio finché l'apparecchiatura non si è completamente raffreddata.

2.4 Pulizia e cura

**AVVERTENZA!**

Vi è il rischio di lesioni, incendio o danni all'apparecchiatura.

- Prima di eseguire qualunque intervento di manutenzione, spegnere l'apparecchiatura ed estrarre la spina dalla presa.
- Controllare che l'apparecchiatura sia fredda. Vi è il rischio che i pannelli in vetro si rompano.
- Sostituire immediatamente i pannelli in vetro della porta nel caso in cui siano danneggiati. Contattare il Centro Assistenza Autorizzato.
- Prestare attenzione quando si rimuove la porta dall'apparecchio. La porta è pesante!
- Pulire regolarmente l'apparecchiatura per evitare il deterioramento dei materiali che compongono la superficie.
- Pulire l'apparecchiatura con un panno inumidito e morbido. Utilizzare solo detergenti neutri. Non usare prodotti abrasivi, spugnette abrasive, solventi od oggetti metallici.
- Se si utilizza uno spray per il forno, seguire attentamente le istruzioni di sicurezza sulla confezione.

2.5 Pulizia per pirolisi

**AVVERTENZA!**

Rischio di lesioni/Incendi/Emissioni chimiche (Fumi) in Modalità Pirolitica.

- Prima di eseguire la pulizia per pirolisi e il preriscaldamento iniziale, rimuovere dalla cavità del forno:

ISTRUZIONI DI SICUREZZA

- eventuali residui di cibo in eccesso, perdite di olio o grasso/versamenti
- eventuali oggetti rimovibili (compresi ripiani, guide laterali, ecc., forniti con l'apparecchiatura), in particolare pentole antiaderenti, gastronorm, lamiere dolci, utensili antiaderenti, ecc.
- Leggere attentamente tutte le istruzioni per la pulizia per pirolisi.
- Tenere i bambini lontano dall'elettrodomestico mentre è in corso la pulizia per pirolisi. L'apparecchiatura diventa molto calda e viene rilasciata aria calda dalle aperture di raffreddamento anteriori.
- La pulizia per pirolisi è un'operazione ad alta temperatura che può rilasciare vapori di residui di cottura e materiali strutturali, pertanto i consumatori sono invitati ad:
 - assicurare una buona ventilazione durante e dopo la pulizia per pirolisi.
 - fornire una buona ventilazione durante e dopo il preriscaldamento iniziale.
- Non versare o applicare acqua sulla porta del forno durante e dopo la pulizia per pirolisi per evitare di danneggiare i pannelli in vetro.
- I vapori rilasciati da tutti i forni pirolitici/residui di cottura vengono definiti come non nocivi per la salute umana, compresi bambini o persone affette da malattie.
- Tenere gli animali domestici lontani dall'elettrodomestico durante e dopo la pulizia per pirolisi e il preriscaldamento iniziale. I piccoli animali domestici (soprattutto uccelli e rettili) possono essere altamente sensibili alle variazioni di temperatura e ai fumi emessi.
- Superfici antiaderenti su pentole, padelle, teglie, utensili, ecc., possono essere danneggiate dalla temperatura elevata della pulizia per pirolisi di tutti i forni pirolitici e possono essere anche una fonte di vapori nocivi a basso livello.

2.6 Cottura a vapore



AVVERTENZA!

Vi è il rischio di ustioni o di danni all'apparecchiatura.

- Il vapore che fuoriesce può provocare ustioni:
 - Prestare attenzione in fase di apertura della porta dell'apparecchiatura quando la funzione è attiva. Può fuoriuscire vapore.
 - Dopo aver impiegato la cottura al vapore aprire la porta dell'apparecchiatura con cautela.

2.7 Illuminazione interna



AVVERTENZA!

Pericolo di scosse elettriche.

- Per quanto riguarda la lampada o le lampade all'interno di questo prodotto e le lampade di ricambio vendute separatamente: Queste lampade sono destinate a resistere a condizioni fisiche estreme negli elettrodomestici, come temperatura, vibrazioni, umidità, o sono destinate a segnalare informazioni sullo stato operativo dell'apparecchio. Non sono destinate ad essere utilizzate in altre applicazioni e non sono adatte per l'illuminazione di ambienti domestici.
- Questo prodotto contiene una sorgente luminosa di classe di efficienza energetica G.
- Servirsi unicamente di lampadine con le stesse specifiche tecniche .

2.8 Assistenza

- Per far riparare l'apparecchiatura, rivolgersi a un Centro di Assistenza Autorizzato.
- Utilizzare solo ricambi originali.

2.9 Smaltimento



AVVERTENZA!

Rischio di lesioni o soffocamento.

- Contattare le autorità locali per ricevere informazioni su come smaltire correttamente l'apparecchiatura.
- Staccare la spina dall'alimentazione elettrica.
- Tagliare il cavo elettrico dell'apparecchiatura e smaltirlo.
- Togliere il blocco porta per evitare che bambini, o animali restino intrappolati nell'apparecchiatura.

3. DESCRIZIONE DEL PRODOTTO

3.1 Panoramica generale

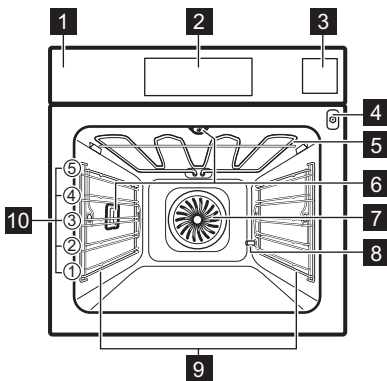

- 1 Pannello dei comandi
- 2 Display
- 3 Vaschetta dell'acqua
- 4 Presa per la termosonda
- 5 Resistenza
- 6 Lampadina
- 7 Ventola
- 8 Uscita tubo di decalcificazione
- 9 Supporto ripiano, rimovibile
- 10 Posizioni ripiano

3.2 Accessori

Ripiano a filo

Per stoviglie, stampi per dolci, arrostiti.

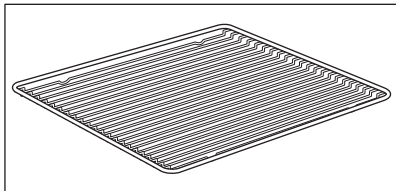

Lamiera dolci

Per torte e biscotti.

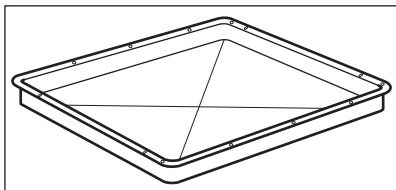

PANNELLO DEI COMANDI

Leccarda

Per cuocere al forno e arrostitire o per raccogliere il grasso.

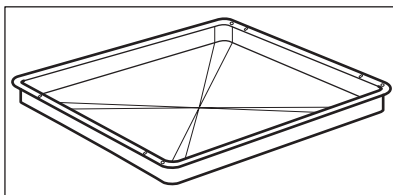

Termosonda

Per misurare la temperatura all'interno delle pietanze.

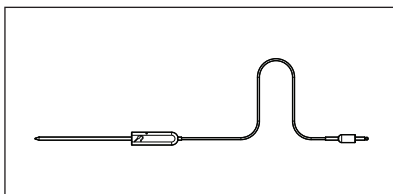

4. PANNELLO DEI COMANDI

4.1 Panoramica del pannello di controllo

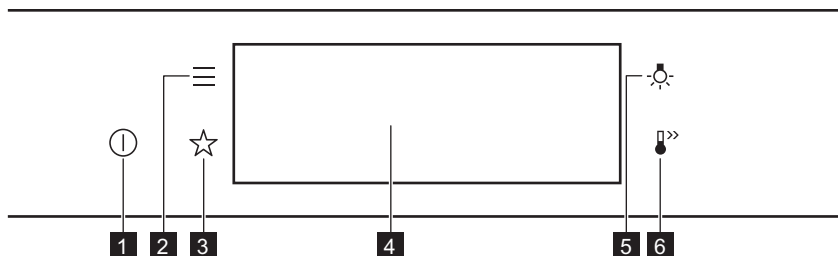









1	ON / OFF	Tenere premuto per accendere e spegnere l'apparecchiatura.
2	Menu	Elenca le funzioni dell'apparecchiatura.
3	Preferiti	Elenca le impostazioni preferite.
4	Display	Mostra le impostazioni correnti dell'apparecchiatura.
5	Interruttore lampadina	Per accendere e spegnere la lampadina.
6	Riscaldamento rapido	Per accendere e spegnere il forno: Riscaldamento rapido.

 <p>Premere</p>	 <p>Spostare</p>	 <p>Tenere premuto</p>
<p>Toccare la superficie con la punta del dito.</p>	<p>Far scivolare la punta della dita sulla superficie.</p>	<p>Toccare la superficie per 3 secondi.</p>

4.2 Display

	<p>Display con le funzioni chiave impostate.</p> <p>A. Imposta ora B. START/STOP C. Temperatura D. Funzioni cottura E. Timer F. Termosonda (solo modelli selezionati)</p>
--	--------------------------------------------------------------------------------------------------------------------------------------------------------------------------------------------------------------------------------------------

Spie display

<p>Indicatori di base - per spostarsi sul display.</p>			
<p>OK Per confermare la selezione / l'impostazione.</p>	<p> Per tornare indietro di un livello nel menu.</p>	<p> Per annullare l'ultima azione.</p>	<p> Per attivare o disattivare le opzioni.</p>
<p>Suono allarme indicatori funzione - al termine del tempo di cottura impostato, viene emesso un segnale acustico.</p>			
<p> La funzione è attiva.</p>	<p> La funzione è attiva. La cottura si arresta automaticamente.</p>	<p> Il suono allarme è disattivato.</p>	
<p>Spie timer</p>			
<p> Per impostare la funzione: Partenza ritardata.</p>	<p> Per annullare l'impostazione.</p>		



5. PRIMA DEL PRIMO UTILIZZO



AVVERTENZA!

Fare riferimento ai capitoli sulla sicurezza.

5.1 Pulizia iniziale



		
Passaggio 1	Passaggio 2	Passaggio 3
Rimuovere gli accessori e i supporti ripiano rimovibili dall'apparecchiatura.	Pulire l'apparecchiatura e gli accessori solo con un panno in microfibra imbevuto di acqua tiepida e detergente delicato.	Collocare gli accessori e i supporti ripiano rimovibili nell'apparecchiatura.

5.2 Prima connessione

Il display mostra un messaggio di benvenuto dopo la prima connessione. È necessario impostare: Lingua, Luminosità, Volume toni, Volume acustico, Durezza dell'acqua, Imposta ora.

5.3 Preriscaldamento iniziale

Preriscaldare il forno vuoto prima di utilizzarlo per la prima volta.





Pas-saggio 1	Rimuovere gli accessori e i supporti ripiano rimovibili dal forno.
Pas-saggio 2	Impostare la temperatura massima per la funzione:  . Lasciare in funzione il forno per un'ora.
Pas-saggio 3	Impostare la temperatura massima per la funzione:  . Lasciare in funzione il forno per 15 minuti.

 Il forno può produrre un odore sgradevole e fumo in fase di preriscaldamento. Accertarsi che la stanza sia ventilata.





5.4 Come impostare: Durezza dell'acqua

Quando si collega il forno alla rete elettrica è necessario impostare il livello di durezza dell'acqua.

Utilizzare la carta di prova o contattare il fornitore dell'acqua per controllare il livello di durezza dell'acqua.

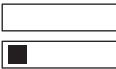
			
Passaggio 1	Passaggio 2	Passaggio 3	Passaggio 4
Immergere la carta di prova nell'acqua per circa 1 sec. Non mettere la carta di prova sotto l'acqua corrente.	Scuotere la carta di prova ed eliminare acqua in eccesso.	Attendere 1 minuto e controllare la durezza dell'acqua con la seguente tabella.	Impostare il livello di durezza dell'acqua: Menu / Impostazioni / Configurazione / Durezza dell'acqua.
<p> I colori della carta di prova continuano a cambiare. Non controllare il livello di durezza dell'acqua più di un minuto dopo il test.</p> <p>È possibile modificare il livello di durezza dell'acqua nel menu: Impostazioni / Configurazione / Durezza dell'acqua.</p>			

La tabella mostra il campo di durezza dell'acqua (dH) con il corrispondente livello di deposito di calcio e la classificazione acqua. Regolare il livello di durezza dell'acqua in base alla tabella.

Durezza dell'acqua		Carta di test	Deposito di calcio (mmol/l)	Deposito di calcio (mg/l)	Classificazione dell'acqua
Livello	Dh				
1	0 - 7		0 - 1.3	0 - 50	dolce
2	8 - 14		1.4 - 2.5	51 - 100	moderatamente dura
3	15 - 21		2.6 - 3.8	101 - 150	dura
4	≥22		≥ 3,9	≥151	molto dura

Quando la durezza dell'acqua del rubinetto è al livello 4, riempire la vaschetta con acqua in bottiglia non gasata.

6. UTILIZZO QUOTIDIANO



AVVERTENZA!

Fare riferimento ai capitoli sulla sicurezza.

6.1 Come impostare: Funzioni cottura

Passaggio 1	Accendere il forno. Il display mostra la funzione cottura predefinita.
Passaggio 2	Premere il simbolo della funzione cottura per accedere al sottomenu.
Passaggio 3	Selezionare la funzione cottura e premere: OK . Il display mostra: temperatura.
Passaggio 4	Impostare: temperatura. Premere: OK .
Passaggio 5	Premere: START . Termosonda - è possibile collegare la termosonda in qualsiasi momento prima o durante la cottura.
STOP - premere per spegnere la funzione cottura.	
Passaggio 6	Spegnere il forno.

6.2 Come impostare: Funzione cottura a vapore

Pas-saggio 1	Accendere il forno. Selezionare e premere il simbolo di funzione cottura per accedere al sottomenu.
Pas-saggio 2	Premere  . Impostare la funzione Riscaldamento a vapore.
Pas-saggio 3	Premere: OK . Il display visualizza le impostazioni di temperatura.
Pas-saggio 4	Impostare la temperatura.
Pas-saggio 5	Premere: OK .

Pas-saggio 6	Premere il coperchio della vaschetta dell'acqua per aprirlo.
Pas-saggio 7	<p>Riempire il cassetto dell'acqua con acqua fredda fino al livello massimo (circa 950 ml) fino a che non viene emesso un segnale acustico o fino a che sul display non compare un messaggio. Non riempire la vaschetta dell'acqua oltre la sua capacità massima. Esiste il rischio di perdite d'acqua, riempimento eccessivo e danni ai mobili.</p> <div style="border: 1px solid black; padding: 5px;"> <p> AVVERTENZA! Utilizzare esclusivamente acqua fredda di rubinetto. Non utilizzare acqua filtrata (demineralizzata) o distillata. Non utilizzare altri liquidi. Non versare liquidi infiammabili o alcolici nella vaschetta dell'acqua.</p> </div>
Pas-saggio 8	Premere per riportare la vaschetta dell'acqua nella posizione iniziale.
Pas-saggio 9	<p>Premere: START . Il vapore appare dopo circa 2 minuti. Quando il forno raggiunge la temperatura impostata, viene emesso un segnale acustico.</p>
Pas-saggio 10	Quando l'acqua presente nella vaschetta si esaurisce, viene emesso un segnale acustico. Riempire nuovamente la vaschetta dell'acqua.
Pas-saggio 11	Spegner il forno.
Pas-saggio 12	<p>Al termine della cottura, vuotare la vaschetta dell'acqua. Fare riferimento al capitolo "Pulizia e cura", Svuotamento serbatoio.</p>
Pas-saggio 13	L'acqua residua può formare della condensa nella cavità. Dopo la cottura, aprire la porta del forno con cautela. Quando il forno è freddo, asciugare la cavità con un panno morbido.

6.3 Come impostare: Cottura guidata

Ogni pietanza di questo sottomenu prevede funzione e temperatura consigliate. È possibile regolare il tempo e la temperatura.



Alcune pietanze possono anche essere cucinate usando:

- Peso automatico
- Termosonda

Il livello fino al quale viene cucinato un piatto:





- Al sangue oppure Meno
- Medio





- Ben cotto oppure Più

Pas-saggio 1	Accendere il forno.
Pas-saggio 2	Premere: 
Pas-saggio 3	Premere:  . Inserire: Cottura guidata.
Pas-saggio 4	Scegliere un piatto o un tipo di alimento.
Pas-saggio 5	Premere: START .





6.4 Funzioni cottura





STANDARD

Funzione cottura	Applicazione
 Grill	Per grigliare alimenti di ridotto spessore e tostare il pane.
 Doppio grill venti-lato	Per arrostitire grandi tagli di carne o pollame con ossa su una posizione della griglia. Per gratinare e dorare.
 Cottura ventilata	Per cuocere su massimo tre posizioni della griglia contemporaneamente ed essiccare i cibi. Impostare la temperatura di 20 - 40°C inferiore rispetto a Cottura convenzionale. .
 Cibi congelati	Per rendere croccanti i cibi confezionati, come ad esempio patatine fritte, crocchette o involtini primavera.



Funzione cottura	Applicazione
 Cottura convenzionale	Per cuocere e arrostitire alimenti su una sola posizione della griglia.
 Funzione Pizza	Per preparare la pizza. Per una doratura intensa e una base croccante.
 Resistenza inferiore	Per dorare torte con base croccante e per conservare gli alimenti.
 Lievitazione pasta	Per velocizzare il processo di lievitazione della pasta lievitata. Evita che la superficie dell'impasto si secchi e la mantiene elastica.

FUNZIONI SPECIALI

Funzione cottura	Applicazione
 Marmellate/ Conserve	Per conservare la verdura (ad esempio: cetrioli sottaceto).
 Essiccazione	Per essiccare frutta a fettine, verdure e funghi.
 Riscaldamento piatti	Per preriscaldare i piatti da servire.
 Scongelamento	Per scongelare gli alimenti (verdura e frutta). Il tempo di scongelamento dipende dalla quantità e dalle dimensioni del cibo congelato.

Funzione cottura	Applicazione
 Gratinato	Per pietanze come lasagne o patate gratinate. Per gratinare e dorare.
 Cottura lenta	Per preparare arrosti teneri e succosi.
 Mantieni caldo	Per tenere in caldo le pietanze.
 Cottura ventilata umida	Questa funzione è progettata per il risparmio energetico durante la cottura. Quando viene usata questa funzione, la temperatura all'interno della cavità potrebbe essere diversa rispetto alla temperatura impostata. Viene utilizzato il calore residuo. La potenza riscaldante potrebbe essere ridotta. Per ulteriori informazioni, consultare il capitolo "Uso quotidiano", Note su: Cottura ventilata umida.

VAPORE

Funzione cottura	Applicazione
 Rigenera a vapore	Il riscaldamento di pietanze col vapore impedisce che la superficie si secchi. Il calore viene distribuito in modo delicato e uniforme, il che consente di recuperare il calore e l'aroma delle pietanze come se fossero state appena preparate. Questa funzione può essere utilizzata per riscaldare il cibo direttamente su un piatto. È possibile riscaldare più piatti contemporaneamente utilizzando diverse posizioni della griglia.
 Cottura Pane	Utilizzare questa funzione per preparare pane e panini con risultati molto buoni simili a quelli professionali in termini di croccantezza, colore e brillantezza della crosta.
 Umidità bassa	La funzione è adatta per carne, pollame, pietanze al forno e sfornati. Con la combinazione del vapore e del calore, la carne acquisisce una consistenza morbida e succosa con una superficie croccante.

6.5 Note su: Cottura ventilata umida

Questa funzione è stata utilizzata per la conformità alla classe energetica e ai requisiti di ecodesign (secondo la normativa EU 65/2014 e EU 66/2014). Test conformemente a: IEC/EN 60350-1

La porta del forno dovrebbe essere chiusa in fase di cottura, in modo che la funzione non venga interrotta. Ciò garantisce inoltre che il forno funzioni con la più elevata efficienza energetica possibile.

Quando viene usata questa funzione, la lampada si spegne automaticamente dopo 30 secondi. Per le istruzioni di cottura rimandiamo al capitolo "Consigli e suggerimenti", Cottura ventilata umida. Per indicazioni generali sul risparmio energetico rimandiamo al capitolo "Efficienza energetica", Risparmio energetico.

7. FUNZIONI DEL TIMER

7.1 Descrizione funzioni orologio

Funzione Orologio	Applicazione
Tempo di cottura	Per impostare la durata della cottura. Il massimo è 23 ore 59 min.
Operazione finale	Per impostare cosa succede quando il timer interrompe il conteggio.
Partenza ritardata	Per posticipare l'inizio e/o la fine della cottura.
Prolunga il tempo	Per prolungare il tempo di cottura.
Promemoria	Per l'impostazione di un conto alla rovescia. Il massimo è 23 h 59 min. Questa funzione non ha nessun effetto sul funzionamento dell'apparecchiatura.
Timer	Monitora da quanto tempo è attiva la funzione. Timer - si può attivarla e disattivarla

7.2 Come impostare: Funzioni Orologio

Come impostare l'orologio	
Pas-saggio 1	Premere: Imposta ora.
Pas-saggio 2	Impostare l'ora. Premere: OK.

FUNZIONI DEL TIMER

Come impostare il tempo di cottura	
Pas-saggio 1	Selezionare la funzione cottura e impostare la temperatura.
Pas-saggio 2	Premere:  .
Pas-saggio 3	Impostare l'ora. Premere: OK .

Come scegliere l'opzione di fine	
Pas-saggio 1	Selezionare la funzione cottura e impostare la temperatura.
Pas-saggio 2	Premere:  .
Pas-saggio 3	Impostare la durata della cottura.
Pas-saggio 4	Premere: ● ● ● .
Pas-saggio 5	Premere: Operazione finale.
Pas-saggio 6	Scegliere il preferito: Operazione finale.
Pas-saggio 7	Premere: OK . Ripetere l'azione fino a quando il display non visualizza la schermata principale.

Come ritardare l'avvio della cottura	
Pas-saggio 1	Impostare la funzione cottura e la temperatura.
Pas-saggio 2	Premere:  .
Pas-saggio 3	Impostare la durata della cottura.
Pas-saggio 4	Premere: ● ● ● .
Pas-saggio 5	Premere: Partenza ritardata.
Pas-saggio 6	Scegliere il valore.
Pas-saggio 7	Premere: OK. Ripetere l'azione fino a quando il display non visualizza la schermata principale.

Come aumentare il tempo di cottura	
Quando rimane il 10% del tempo di cottura e gli alimenti sembrano non essere cotti sarà possibile aumentare il tempo di cottura. Sarà inoltre possibile modificare la funzione cottura.	
Premere +1min per aumentare il tempo di cottura.	

Come modificare le impostazioni timer	
Pas-saggio 1	Premere:  .

Come modificare le impostazioni timer

**Pas-
saggio
2**

Impostare il valore del timer.

**Pas-
saggio
3**

Premere: OK.

Sarà possibile impostare il tempo modificato in fase di cottura, in qualsiasi momento.

8. UTILIZZO DEGLI ACCESSORI



AVVERTENZA!

Fare riferimento ai capitoli sulla sicurezza.

8.1 Inserimento di accessori

Un piccolo rientro sulla parte superiore aumenta il livello di sicurezza. Gli incavi sono anche dispositivi antiribaltamento. Il bordo alto intorno al ripiano evita che pentole e padelle scivolino dal ripiano.

Ripiano a filo:

Spingere il ripiano fra le guide del supporto.

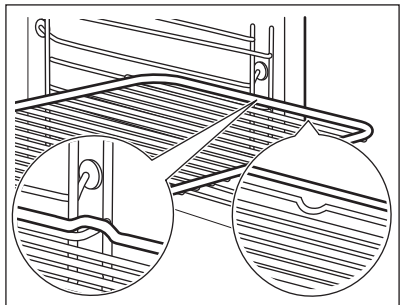

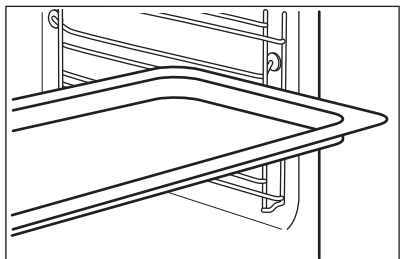

Lamiera dolci / Teglia profonda:

Spingere la lamiera tra le guide del supporto ripiano.



8.2 Termosonda

Termosonda - misura la temperatura all'interno del cibo. Si può utilizzare con ogni funzione cottura.

Le temperature da impostare sono due:	
 La temperatura del forno: minimo 120 °C.	 La temperatura interna.



Per i migliori risultati di cottura:		
Gli ingredienti dovrebbero essere a temperatura ambiente.	Non usarlo per pietanze liquide.	Durante la cottura deve rimanere nel piatto.

Il forno calcola un orario di fine cottura approssimativo. Dipende dalla quantità di cibo, dalla funzione del forno impostata e dalla temperatura.

8.3 Istruzioni d'uso: Termosonda

Pas-saggio 1	Accendere il forno.	
Pas-saggio 2	Impostare una funzione cottura e, se necessario, la temperatura del forno.	
Pas-saggio 3	Inserire: Termosonda.	
Carne, pollame e pesce	Sformato	
Inserire la punta della Termosonda al centro della carne, del pesce nella parte più spessa, ove possibile. Assicurarsi che almeno 3/4 del Termosonda sia all'interno del piatto.	Inserire la punta della Termosonda esattamente al centro della casseruola. Termosonda dovrebbe essere stabilizzato in un punto in fase di cottura. Usare un ingrediente solido per ottenere questo risultato. Usare il bordo del piatto di cottura per supportare l'impugnatura in silicone della Termosonda. La punta di Termosonda non deve toccare il fondo di una teglia.	

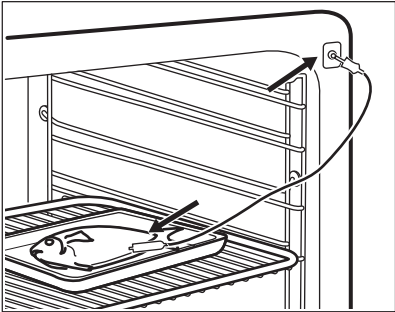
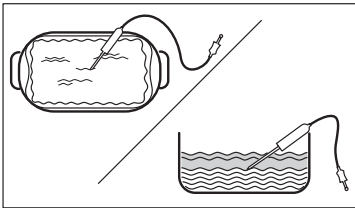

FUNZIONI AGGIUNTIVE

	
Pas-saggio 4	Collegare la Termosonda nella presa sulla parte anteriore del forno. Sul display appare la temperatura attuale di: Termosonda.
Pas-saggio 5	 - premere per impostare la temperatura al cuore del sensore.
Pas-saggio 6	<ul style="list-style-type: none">● ● ● - premere per impostare l'opzione preferita:• Suono allarme - quando il cibo raggiunge la temperatura al centro, viene emesso un segnale acustico.• Suono allarme e termine cottura - quando la pietanza raggiunge la temperatura al centro, viene emesso un segnale acustico e il forno si ferma.
Pas-saggio 7	Selezionare l'opzione e premere ripetutamente: OK per accedere alla schermata principale.
Pas-saggio 8	Premere: START . Quando il cibo raggiunge la temperatura impostata, viene emesso un segnale acustico. Si può scegliere se arrestare la cottura o continuarla per essere sicuri che l'alimento sia ben cotto.
Pas-saggio 9	Estrarre Termosonda la spina dalla presa e rimuovere la pietanza dal forno. <div data-bbox="213 1214 1028 1305" style="border: 1px solid black; padding: 5px;"> AVVERTENZA! Rischio di ustioni perchè Termosonda diventa bollente. Fare attenzione in fase di rimozione ed estrazione dalla pietanza.</div>

9. FUNZIONI AGGIUNTIVE



9.1 Come salvare: Preferiti

È possibile salvare le impostazioni preferite, come la funzione cottura, il tempo di cottura, la temperatura, o la funzione di pulizia. È possibile salvare 3 impostazioni preferite.

Pas-saggio 1	Accendere l'apparecchiatura.
Pas-saggio 2	Selezionare l'impostazione preferita.
Pas-saggio 3	Premere:  . Selezionare: Preferiti.
Pas-saggio 4	Selezionare: Salva impostazioni correnti.
Pas-saggio 5	Premere + per aggiungere l'impostazione all'elenco di: Preferiti. Premere OK.
<p> - premere per ripristinare l'impostazione.</p> <p> - premere per annullare l'impostazione.</p>	

9.2 Blocco tasti



Questa funzione evita che si cambi per sbaglio la funzione cottura.

Pas-saggio 1	Accendere l'apparecchiatura.
Pas-saggio 2	Imposta una funzione di cottura.
Pas-saggio 3	 ,  - premere contemporaneamente per attivare la funzione.
Per disattivare la funzione, ripetere il passaggio 3.	

9.3 Spegnimento automatico

Per ragioni di sicurezza, l'elettrodomestico si spegne dopo un determinato periodo di tempo se è attiva una funzione di riscaldamento e non si modificano le impostazioni.

CONSIGLI E SUGGERIMENTI UTILI

 (°C)	 (ora)
30 - 115	12.5
120 - 195	8.5
200 - 245	5.5
250 - massimo	3

Lo spegnimento automatico non funziona con le funzioni: Luce forno, Termosonda, Orario fine, Cottura lenta.

9.4 Ventola di raffreddamento

Quando l'apparecchiatura è in funzione, la ventola di raffreddamento si attiva in modo automatico per raffreddare le superfici. Dopo aver spento l'apparecchiatura, la ventola di raffreddamento continua a funzionare finché l'apparecchiatura non si è raffreddata.

10. CONSIGLI E SUGGERIMENTI UTILI





10.1 Consigli di cottura

<p>La temperatura e i tempi di cottura specificati nelle tabella sono valori indicativi. Dipendono dalle ricette, dalla qualità e quantità degli ingredienti utilizzati.</p> <p>La nuova apparecchiatura può cuocere o arrostitire in modo differente rispetto all'apparecchiatura posseduta in precedenza. I suggerimenti seguenti mostrano le impostazioni consigliate per temperatura, tempo di cottura e posizione ripiano per tipi di alimenti specifici.</p> <p>Qualora non si trovino le impostazioni per una ricetta speciale, cercarne una simile.</p> <p>Per ulteriori informazioni sulla cottura rimandiamo alle tabelle di cottura sul nostro sito web. Per trovare i Suggerimenti di Cottura, controllare il numero PNC sulla targhetta dei dati sul telaio anteriore della cavità dell'apparecchiatura.</p>

10.2 Cottura ventilata umida



Per ottenere i risultati migliori, attenersi ai suggerimenti elencati nella tabella sottostante.

CONSIGLI E SUGGERIMENTI UTILI

		 (°C)		 (min.)
Roll dolci, 16 pezzi	vassoio di cottura o leccarda	180	2	25 - 35
Rotolo con marmellata	vassoio di cottura o leccarda	180	2	15 - 25
Pesce intero, 0,2 kg	vassoio di cottura o leccarda	180	3	15 - 25
Dolcetti, 16 pezzi	vassoio di cottura o leccarda	180	2	20 - 30
Meringhe, 24 pezzi	vassoio di cottura o leccarda	160	2	25 - 35
Muffin, 12 pezzi	vassoio di cottura o leccarda	180	2	20 - 30
Pasta saporita, 20 pezzi	vassoio di cottura o leccarda	180	2	20 - 30
Biscotti di pasta frolla, 20 pezzi	vassoio di cottura o leccarda	140	2	15 - 25
Tartellette, 8 pezzi	vassoio di cottura o leccarda	180	2	15 - 25

10.3 Cottura ventilata umida - accessori consigliati

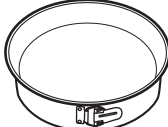



Usare scatole e contenitori scuri e non riflettenti. Assorbono meglio il calore rispetto al colore chiaro e ai piatti riflettenti.

			
Teglia da pizza	Pirofila	Pirofile monoporzione	Tortiera per flan
Scura, non riflettente 28 cm di diametro	Scura, non riflettente 26 cm di diametro	Ceramica diametro 8 cm, altezza 5 cm	Scura, non riflettente 28 cm di diametro





10.4 Tabelle di cottura per gli istituti di test

Informazioni per gli istituti di test





Test conformemente a: EN 60350, IEC 60350.
Cottura al forno su un livello - cottura in stampi

		 °C	 min	
Pan di Spagna senza grassi	Cottura ventilata	160	45 - 60	2
Pan di Spagna senza grassi	Cottura convenzionale	160	45 - 60	2
Torta di mele americana, 2 stampi Ø20 cm	Cottura ventilata	160	55 - 65	2
Torta di mele americana, 2 stampi Ø20 cm	Cottura convenzionale	180	55 - 65	1
Frollini al burro	Cottura ventilata	140	25 - 35	2
Frollini al burro	Cottura convenzionale	140	25 - 35	2

Cottura al forno su un livello - biscotti
Utilizzare la posizione del terzo ripiano.

		 °C	 min
Tortine, 20 per teglia, preriscaldare il forno vuoto	Cottura ventilata	150	20 - 30
Tortine, 20 per teglia, preriscaldare il forno vuoto	Cottura convenzionale	170	20 - 30





Cottura al forno multilivello - biscotti

		 °C	 min	
Frollini al burro	Cottura ventilata	140	25 - 45	2 / 4
Tortine, 20 per teglia, preriscaldare il forno vuoto	Cottura ventilata	150	25 - 35	1 / 4
Pan di Spagna senza grassi	Cottura ventilata	160	45 - 55	2 / 4
Crostata di mele, 1 stampo per griglia (Ø 20 cm)	Cottura ventilata	160	55 - 65	2 / 4

Grill

Preriscaldare il forno vuoto per 5 minuti.

Grigliare con l'impostazione di temperatura massima.

		 min	
Toast	Grill	1 - 2	5
Manzo, bistecca, girare il piatto a metà cottura	Grill	24 - 30	4

11. PULIZIA E CURA





AVVERTENZA!

Fare riferimento ai capitoli sulla sicurezza.

11.1 Note sulla pulizia

 Agenti di pulizia	Pulire la parte anteriore dell'apparecchiatura solo con un panno in microfibra imbevuto di acqua tiepida e detergente delicato.
	Servirsi di una soluzione detergente per pulire le superfici metalliche.
	Pulire le macchie con un detergente delicato.

 Uso quotidiano	<p>Pulire la cavità dopo ogni utilizzo. L'accumulo di grasso o di altri residui potrebbe causare un incendio.</p>
	<p>Non lasciare le vivande nell'apparecchiatura per più di 20 minuti. Asciugare la cavità dopo ogni utilizzo solo con un panno in microfibra.</p>

 Accessori	<p>Pulire tutti gli accessori dopo ogni utilizzo e lasciarli asciugare. Utilizzare solo un panno in microfibra imbevuto di acqua tiepida e un detergente delicato. Non pulire gli accessori in lavastoviglie.</p>
	<p>Non pulire gli accessori anti-aderenti con agenti abrasivi o oggetti appuntiti.</p>

11.2 Come rimuovere: Supporti del ripiano

Rimuovere i supporti ripiano per pulire il forno.

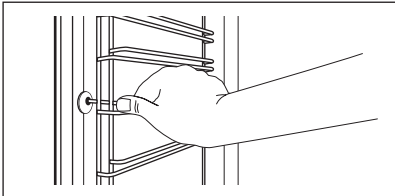
Pas-saggio 1	<p>Spegner il forno e attendere che si raffreddi.</p>	
Pas-saggio 2	<p>Estrarre il supporto ripiano, tirando con delicatezza verso l'alto.</p>	
Pas-saggio 3	<p>Sfilare dapprima l'estremità anteriore del supporto del ripiano dalla parete laterale.</p>	
Pas-saggio 4	<p>Estrai il supporto per ripiano dal fermo posteriore.</p>	
<p>Installare i supporti ripiani seguendo al contrario la procedura indicata.</p>		

11.3 Istruzioni d'uso: Pulizia per pirolisi

Pulire il forno con Pulizia per pirolisi.

	<p>AVVERTENZA! Rischio di ustioni.</p>
------------------------------------------------------------------------------------	---------------------------------------------------

	<p>ATTENZIONE! Se nello stesso armadietto sono installate altre apparecchiature, non utilizzarle allo stesso tempo di questa funzione. Il forno potrebbe subire danni.</p>
------------------------------------------------------------------------------------	---------------------------------------------------------------------------------------------------------------------------------------------------------------------------------------

Prima della Pulizia per pirolisi:

Spegnere il forno e attendere che si raffreddi.	Rimuovere tutti gli accessori.	Pulire la base del forno e il vetro interno dello sportello con acqua calda, un panno morbido e un detergente delicato.
-------------------------------------------------	--------------------------------	-------------------------------------------------------------------------------------------------------------------------

Non riempire il serbatoio dell'acqua durante la pulizia. Riavvia il ciclo di pulizia.

Pas-saggio 1	Accendere il forno.
Pas-saggio 2	Premere:  Pulizia.
Pas-saggio 3	Mettere il ripiano di cottura sulla prima posizione per raccogliere acqua dal serbatoio dall'acqua. OK - premere per avviare lo svuotamento del serbatoio dell'acqua.
Pas-saggio 4	Una volta svuotato il serbatoio, rimuovere la lamiera dolci e i supporti del ripiano rimovibili. Pulire la cavità del forno e il vetro interno dello sportello con un panno morbido. Premere: OK.
Pas-saggio 5	Selezionare la modalità di pulizia.

Opzione	Modalità di pulizia	Durata
Pulizia per pirolisi, rapido	Pulizia leggera	1 h
Pulizia per pirolisi, normale	Pulizia normale	1 h 30 min
Pulizia per pirolisi, intenso	Pulizia completa	3 h

① All'avvio della pulizia, la lampada è spenta e la ventola di raffreddamento funziona a velocità maggiore.

STOP - premere per interrompere la pulizia prima che sia terminata.

Non utilizzare il forno fino a che il simbolo di blocco sportello non scompare dal display.

Al termine della pulizia:

Spegnere il forno e attendere che si raffreddi.	Pulire la cavità con un panno morbido.	Rimuovere il residuo dal basso della cavità.
-------------------------------------------------	----------------------------------------	----------------------------------------------

11.4 Promemoria Pulizia

Si consiglia di eseguire la pulizia, quando appare il promemoria.

Utilizzare la funzione: Pulizia per pirolisi.

11.5 Istruzioni d'uso: Decalcificazione

Prima di iniziare:

Spegnere il forno e attendere che si raffreddi.	Rimuovere tutti gli accessori.	Assicurarsi che la vaschetta dell'acqua sia vuota.
-------------------------------------------------	--------------------------------	----------------------------------------------------

Durata della prima parte: circa 100 min

Pas-saggio 1	Mettere la leccarda nel primo ripiano.
Pas-saggio 2	Versare 250 ml di agente decalcificante nella vaschetta dell'acqua.
Pas-saggio 3	Riempire la parte restante della vaschetta dell'acqua fino al livello massimo finché non viene emesso un segnale acustico o il display non mostra un messaggio.
Pas-saggio 4	Selezionare: Menu / Pulizia.
Pas-saggio 5	Attivare la funzione e seguire le istruzioni sul display. Viene avviata la prima fase della procedura di decalcificazione.
Pas-saggio 6	Dopo aver concluso la prima parte, svuotare la leccarda e riposizionarla sulla prima posizione del ripiano.

Durata della seconda parte: circa 35 min	
Pas-saggio 7	Riempire la parte restante della vaschetta dell'acqua fino al livello massimo finché non viene emesso un segnale acustico o il display non mostra un messaggio.
Pas-saggio 8	Al termine della funzione, rimuovere la leccarda.
 Quando questa funzione è attiva, la lampada è spenta.	

Al termine della decalcificazione:		
Spegnere il forno.	Quando il forno è freddo, asciugare la cavità con un panno morbido.	Lasciare aperta la porta del forno e attendere che la cavità sia asciutta.
 Se dopo la decalcificazione rimangono dei residui di calcare nel forno, il display invita a ripetere la procedura.		

11.6 Promemoria trattamento anticalcare

Due promemoria ricordano di eseguire il trattamento anticalcare sul forno. Non è possibile disattivare il promemoria relativo al trattamento anticalcare.

Tipo	Descrizione
Promemoria soft	Consiglia di eseguire il trattamento anticalcare sul forno.
Promemoria hard	Obbliga a eseguire il trattamento anticalcare sul forno. Se non si esegue la decalcificazione del forno quando è attivo il promemoria "hard", le funzioni vapore sono disattivate.

11.7 Istruzioni d'uso: Risciacquo

Prima di iniziare:	
Spegnere il forno e attendere che si raffreddi.	Rimuovere tutti gli accessori.

PULIZIA E CURA

Pas-saggio 1	Mettere la leccarda nel primo ripiano.
Pas-saggio 2	Riempire la vaschetta dell'acqua fino al livello massimo finché non viene emesso un segnale acustico o il display non mostra un messaggio.
Pas-saggio 3	Selezionare: Menu / Pulizia / Risciacquo. Durata: circa 30 min
Pas-saggio 4	Attivare la funzione e seguire le istruzioni sul display.
Pas-saggio 5	Al termine della funzione, rimuovere la leccarda.
 Quando questa funzione è attiva, la lampada è spenta.	

11.8 Modalità d'uso: Svuotamento serbatoio

Usalo dopo la cottura con la funzione cottura a vapore per rimuovere l'acqua residua dalla vaschetta dell'acqua.

Prima di iniziare:	
Spegnere il forno e attendere che si raffreddi.	Rimuovere tutti gli accessori.

Pas-saggio 1	Mettere la leccarda nel primo ripiano.
Pas-saggio 2	Selezionare: Menu / Pulizia / Svuotamento serbatoio. Durata: 6 min
Pas-saggio 3	Attivare la funzione e seguire le istruzioni sul display.
Pas-saggio 4	Al termine della funzione, rimuovere la leccarda.

i Quando questa funzione è attiva, la lampada è spenta.

11.9 Procedura di rimozione e installazione: Porta

È possibile rimuovere la porta e i pannelli in vetro interni per procedere alle operazioni di pulizia. Il numero di pannelli di vetro varia a seconda dei modelli.



AVVERTENZA!

La porta è pesante.



ATTENZIONE!

Maneggiare con cura il vetro, in particolare intorno ai bordi del pannello frontale. Il vetro può rompersi.

Pas-saggio 1	Aprire completamente la porta.	
Pas-saggio 2	Sollevare e premere le leve di serraggio (A) sulle due cerniere.	
Pas-saggio 3	Chiudere la porta del forno fino alla prima posizione di apertura (un angolo di circa 70°). Afferrare la porta su entrambi i lati e tirarla fino ad allontanarla dal forno mantenendo un'inclinazione verso l'alto. Poggiare la porta con il lato esterno rivolto verso il basso su un panno morbido su una superficie stabile.	
Pas-saggio 4	Tenere il rivestimento della porta (B) sul bordo superiore della porta da entrambi i lati e spingere verso l'interno per sbloccare la guarnizione a clip.	
Pas-saggio 5	Rimuovere il rivestimento tirandolo in avanti.	
Pas-saggio 6	Afferrare uno ad uno i pannelli di vetro della porta dal bordo superiore e estrarli dalla guida.	

PULIZIA E CURA

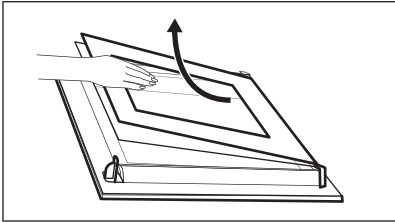
Pas-saggio 7	Pulire il pannello in vetro con acqua e sapone. Asciugare con cura il pannello in vetro. Non pulire i pannelli in vetro in lavastoviglie.	
Pas-saggio 8	Dopo la pulizia, eseguire i passaggi di cui sopra nella sequenza opposta.	
Pas-saggio 9	Installare per primo il pannello più piccolo, poi quello più grande e la porta.	

11.10 Come sostituire: Lampadina



AVVERTENZA!

Pericolo di scosse elettriche.
La lampada potrebbe essere calda.

Prima di sostituire la lampadina:

Passagio 1	Passagio 2	Passagio 3
Spegnere il forno. Attendere che il forno sia freddo.	Estrarre la spina dalla presa di corrente.	Appoggiare un panno sul fondo della cavità.

Lampadina superiore

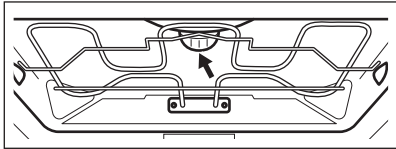
Pas-saggio 1	Girare il rivestimento di vetro per toglierlo.	
Pas-saggio 2	Rimuovi l'anello metallico e pulisci il coperchio in vetro.	
Pas-saggio 3	Sostituire la lampadina con una resistente al calore fino a 300 °C.	

Pas-saggio 4	Montare l'anello in metallo sulla calotta di vetro e installarlo.
---------------------	-------------------------------------------------------------------

Lampadina laterale

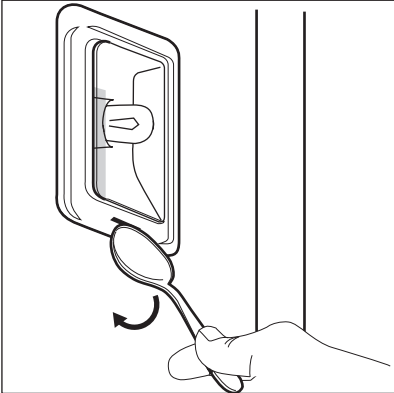
Pas-saggio 1	Rimuovere il supporto per il ripiano sinistro per accedere alla lampadina.	
Pas-saggio 2	Utilizzare un oggetto stretto e smussato (ad es. un cucchiaino) per rimuovere il rivestimento in vetro.	
Pas-saggio 3	Pulire il coperchio in vetro.	
Pas-saggio 4	Sostituire la lampadina con una resistente al calore fino a 300 °C.	
Pas-saggio 5	Installare il coperchio in vetro.	
Pas-saggio 6	Installare il supporto per il ripiano sinistro.	



12. RISOLUZIONE DEI PROBLEMI





AVVERTENZA!

Fare riferimento ai capitoli sulla sicurezza.

12.1 Cosa fare se...



 L'apparecchiatura non si accende o non si riscalda	
 Causa possibile	 Soluzione
L'elettrodomestico non è collegato a una fonte di alimentazione elettrica o non è collegato correttamente.	Accertarsi che l'elettrodomestico sia collegato correttamente all'alimentazione elettrica.
L'orologio non è impostato.	Impostare l'orologio, per i dettagli fare riferimento a Funzioni Orologio capitolo, Come impostare: Funzioni Orologio.
La porta non è chiusa correttamente.	Chiudere completamente lo sportello.
È saltato il fusibile.	Assicurarsi che il fusibile sia la causa del problema. Qualora il problema si ripresenti, contattare un elettricista qualificato.
L'apparecchiatura Sicurezza bambini è accesa.	Rimandiamo al capitolo "Menu", Sottomenu per: Opzioni.

 Componenti	
 Descrizione	 Soluzione
La lampadina è bruciata.	Sostituire la lampadina, per ulteriori dettagli rimandiamo al capitolo "Pulizia e cura". Come effettuare la sostituzione: Lampadina.

Interrompere la pulizia in caso di interruzioni di corrente. Ripetere l'operazione di pulizia se viene interrotta da un guasto di corrente.

12.2 Come gestire: Codici di errore

Quando si verifica un errore software, il display mostra un messaggio di errore. In questa sezione verrà presentato un elenco dei problemi che è possibile gestire autonomamente.

 Codice e descrizione	 Soluzione
C2 - la Termosonda è nella cavità dell'apparecchiatura durante Pulizia per pirolisi.	Estrarre la Termosonda.
C3 - la porta non è chiusa completamente durante Pulizia per pirolisi.	Chiudere la porta.
F111 – Termosonda non è inserita correttamente nella presa.	Collegare la spina completamente Termosonda nella presa.
F240, F439 - i campi touch sul display non funzionano correttamente.	Pulire la superficie del display. Verificare che non ci sia sporczia sui campi touch.
F908 - il sistema dell'apparecchiatura non si può collegare al pannello di controllo.	Accendere e spegnere dell'apparecchiatura.

12.3 Dati dell'Assistenza

Qualora non sia possibile trovare una soluzione al problema, contattare il rivenditore o un Centro di assistenza autorizzato.

Le informazioni necessarie per il Centro Assistenza si trovano sulla targhetta dei dati. La targhetta si trova sul telaio anteriore della cavità dell'apparecchiatura. Non rimuovere la targhetta dei dati dalla cavità dell'apparecchiatura.

Consigliamo di annotare i dati qui:	
Modello (Mod.)
Codice prodotto (PNC)
Numero di serie (S.N.)

13. EFFICIENZA ENERGETICA

13.1 Informazioni sul prodotto e scheda informativa sul prodotto

Nome del fornitore	AEG
Identificazione modello	BSE77280M 944188685 BSE77228BM 944188655 BSK772280M 944188643 BSS772280B 944188644

Indice di efficienza energetica	61,2	
Classe di efficienza energetica	A++	
Consumo energetico con carico standard, modalità tradizionale	1,09 kWh/ciclo	
Consumo di energia con un carico standard, modalità a circolazione d'aria forzata	0,52 kWh/ciclo	
Numero di cavità	1	
Fonte di calore	Elettricità	
Volume	71 l	
Tipo di forno	Forno da incasso	
Massa	BSE772280M	36.0 kg
	BSE77228BM	36.0 kg
	BSK772280M	36.0 kg
	BSS772280B	36.0 kg

IEC/EN 60350-1 - Apparecchiature elettriche per la cottura per uso domestico - Parte 1: Cucine, forni, forni a vapore e griglie - Metodi per la misura delle prestazioni.

13.2 Risparmio energetico



L'apparecchiatura ha di funzioni che consentono di aiutarvi a risparmiare energia durante le operazioni di cottura di tutti i giorni.

Assicurarsi che la porta dell'apparecchiatura sia chiusa quando l'apparecchiatura è in funzione. Non aprire troppo spesso la porta durante la cottura. Tenere pulita la guarnizione della porta e assicurarsi che sia ben fissata nella posizione corretta.

Servirsi di pentole in metallo per migliorare il risparmio energetico .

Ove possibile, non pre-riscaldare l'apparecchiatura prima della cottura.

Ridurre quanto più possibile gli intervalli fra le diverse operazioni di cottura quando vengono preparati più piatti contemporaneamente.

Cucinare con ventola

Ove possibile, servirsi delle funzioni di cottura con la ventola per risparmiare energia.

Calore residuo

Se si attiva un programma con la selezione Durata e il tempo di cottura è superiore a 30 minuti, in alcune funzioni dell'apparecchiatura le resistenze si spengono automaticamente in anticipo.

La ventola e la lampada continuano a funzionare. Quando si spegne l'apparecchiatura, il display visualizza il calore residuo. Si può usare quel calore per mantenere le pietanze in caldo.

Quando la durata di cottura è superiore ai 30 minuti, ridurre la temperatura dell'apparecchiatura al minimo 3-10 minuti prima della fine del processo di cottura. La cottura proseguirà grazie al calore residuo all'interno dell'apparecchiatura.

Utilizzare il calore residuo per scaldare altri piatti.

Tenere in caldo gli alimenti

Scegliere l'impostazione di temperatura più bassa per sfruttare il calore residuo e mantenere calda la pietanza. La spia di calore residuo o la temperatura compaiono sul display.

Cottura con lampada spenta

Spegnere la lampada in fase di cottura. Accenderla solo quando è necessario.

Cottura ventilata umida

Funzione progettata per risparmiare energia in fase di cottura.

Quando si utilizza questa funzione, la lampadina si spegne automaticamente dopo 30 secondi.

È possibile riaccendere la lampada, ma questa azione ridurrà i risparmi energetici previsti.

14. STRUTTURA DEL MENU

14.1 Menu

Voce menu		Applicazione
Cottura guidata		Elenca i programmi automatici.
Pulizia		Elenca i programmi di pulizia.
Preferiti		Elenca le impostazioni preferite.
Opzioni		Per impostare la configurazione dell'apparecchiatura.
Impostazioni	Configurazione	Per impostare la configurazione dell'apparecchiatura.
	Assistenza tecnica	Mostra la versione del software e la configurazione.

14.2 Sottomenu per: Pulizia

Sottomenu	Applicazione
Svuotamento serbatoio	Procedura per la rimozione dell'acqua residua dalla relativa vaschetta dopo aver utilizzato le funzioni vapore.
Pulizia per pirolisi, rapido	Durata: 1 h.
Pulizia per pirolisi, normale	Durata: 1 h 30 min.
Pulizia per pirolisi, intenso	Durata: 3 h.

STRUTTURA DEL MENU

Sottomenu	Applicazione
Decalcificazione	Procedura per la pulizia del circuito di generazione vapore dal calcare residuo.
Risciacquo	Procedura di risciacquo e pulizia del circuito di generazione vapore dopo un utilizzo frequente delle funzioni a vapore.

14.3 Sottomenu per: Opzioni

Sottomenu	Applicazione
Luce forno	Accensione e spegnimento della lampada.
Sicurezza bambini	Previene l'attivazione accidentale dell'apparecchiatura. Quando l'opzione è attiva, il testo Sicurezza bambini compare sul display all'accensione dell'apparecchiatura. Per abilitare l'uso dell'apparecchiatura, scegliere le lettere del codice in ordine alfabetico. Quando l'opzione è attiva e l'apparecchiatura è spenta, la porta dell'apparecchiatura è bloccata. L'accesso al timer, all'operazione da remoto e alla lampadina è disponibile con l'opzione attiva.
Riscaldamento rapido	Riduce il tempo di riscaldamento. È disponibile solo per alcune delle funzioni dell'apparecchiatura.
Visualizza ora	Accende e spegne l'orologio.
Visualizzazione orario digitale	Cambia il formato dell'indicazione oraria visualizzata.

14.4 Sottomenu per: Configurazione

Sottomenu	Descrizione
Lingua	Imposta la lingua dell'apparecchiatura.
Luminosità	Imposta la luminosità del display.
Volume toni	Attiva e disattiva il tono dei tasti a sfioramento. Non è possibile disattivare i segnali acustici per: ①.

Sottomenu	Descrizione
Volume acustico	Imposta il volume delle tonalità e dei segnali dei tasti.
Durezza dell'acqua	Imposta la durezza dell'acqua.
Imposta ora	Imposta l'ora e la data attuali.

14.5 Sottomenu per: Assistenza tecnica

Sottomenu	Descrizione
Modalità demo	Codice di attivazione/disattivazione: 2468
Versione software	Informazioni sulla versione software.
Ripristino impostazioni iniziali di fabbrica	Ripristina le impostazioni di fabbrica.

15. È SEMPLICE!



Prima di iniziare a usare il dispositivo sarà necessario impostare:



Lingua	Luminosità	Volume toni	Volume acustico	Durezza dell'acqua	Imposta ora
--------	------------	-------------	-----------------	--------------------	-------------

Iniziare a utilizzare l'apparecchiatura

Avvio rapido	Accendere l'apparecchiatura e avviare la cottura con la temperatura predefinita e l'orario della funzione.	Passaggio 1	Passaggio 2	Passaggio 3
		Tenere premuto: ①.	<input type="checkbox"/> ... - selezionare la funzione preferita.	Premere: START.
Spegnimento rapido	Spegnere l'apparecchiatura, su qualsiasi schermo o messaggio in qualsiasi momento.	① - tenere premuto finché non si spegne l'apparecchiatura.		



È SEMPLICE!

Avviare la cottura				
Passaggio 1	Passaggio 2	Passaggio 3	Passaggio 4	Passaggio 5
 - premere per accendere l'apparecchiatura.	 ... - selezionare la funzione cottura.	°C - impostare la temperatura.	OK - premere per confermare.	START - premere per avviare il processo di cottura.

Scopri come cucinare in modo rapido				
Utilizza i programmi automatici per preparare rapidamente una pietanza con le impostazioni predefinite:				
Cottura guidata	Passaggio 1	Passaggio 2	Passaggio 3	Passaggio 4
	Premere:  .	Premere:  .	Premere:  Cottura guidata.	Scegliere il piatto.

Usare le funzioni rapide per impostare il tempo di cottura necessario	
Funzione Finish Assist 10% Usare la Funzione Finish Assist 10% per aggiungere ulteriore tempo quando rimane il 10% del tempo di cottura.	Per allungare il tempo di cottura, premere +1min.

16. CONSIDERAZIONI SULL'AMBIENTE

Riciclare i materiali con il simbolo . Buttare l'imballaggio negli appositi contenitori per il riciclaggio. Aiutare a proteggere l'ambiente e la salute umana e a riciclare rifiuti derivanti da apparecchiature elettriche ed elettroniche. Non smaltire le apparecchiature che riportano il simbolo  insieme ai normali rifiuti domestici. Portare il prodotto al punto di riciclaggio più vicino o contattare il comune di residenza.

PARA UNOS RESULTADOS PERFECTOS

Gracias por elegir este producto AEG. Lo hemos creado para brindarle un rendimiento impecable durante muchos años, con tecnologías innovadoras que lo ayudan a simplificar la vida, características que quizás no encuentre en los electrodomésticos comunes. Dedique unos minutos a leer este documento para sacarle el máximo partido.

Visite nuestro sitio web para:



Obtener consejos, folletos, soluciones a problemas e información de servicio y reparación:

www.aeg.com/support



Registrar su producto para recibir un mejor servicio:

www.registreaeg.com



Comprar accesorios, artículos de consumo y piezas de recambio originales para su aparato:

www.aeg.com/shop

ATENCIÓN AL CLIENTE Y SERVICIO

Le recomendamos que utilice recambios originales.

Cuando se ponga en contacto con nuestro Centro de servicio técnico, asegúrese de tener los siguientes datos disponibles: Modelo, código numérico del producto (PNC), número de serie. La información se encuentra en la placa de características.

 Advertencia / Precaución - Información sobre seguridad

 Información general y consejos

 Información relativa al medioambiente

Salvo modificaciones.

CONTENIDO

1. INFORMACIÓN SOBRE SEGURIDAD... 256	3. DESCRIPCIÓN DEL PRODUCTO..... 263
1.1 Seguridad de niños y personas vulnerables..... 257	3.1 Resumen general..... 263
1.2 Instrucciones generales de seguridad..... 257	3.2 Accesorios..... 263
2. INSTRUCCIONES DE SEGURIDAD..... 259	4. PANEL DE MANDOS..... 264
2.1 Instalación..... 259	4.1 Vista general del panel de control..... 264
2.2 Conexión eléctrica..... 260	4.2 Pantalla..... 265
2.3 Uso..... 260	5. ANTES DEL PRIMER USO..... 266
2.4 Mantenimiento y limpieza..... 261	5.1 Limpieza inicial 266
2.5 Limpieza Piroclítica..... 261	5.2 Primera conexión..... 266
2.6 Cocción al vapor..... 262	5.3 Precalentamiento inicial..... 266
2.7 Iluminación interna..... 262	5.4 Cómo ajustar: Dureza del agua... 266
2.8 Asistencia técnica..... 262	6. USO DIARIO..... 267
2.9 Eliminación..... 263	6.1 Cómo ajustar: Funciones de cocción..... 268

6.2	Cómo ajustar: Función de cocción al vapor.....	268	11.2	Cómo quitar: Carriles de apoyo	282
6.3	Cómo configurar:		11.3	Instrucciones de uso:	
	Cocción asistida.....	269		Limpieza pirolítica.....	282
6.4	Funciones de cocción.....	269	11.4	Aviso de limpieza.....	284
6.5	Notas sobre: Horneado húmedo + ventilador.....	272	11.5	Instrucciones de uso: Descalcificación.....	284
7.	FUNCIONES DEL RELOJ.....	272	11.6	Avisador para descalcificación..	285
	7.1 Descripción de funciones de reloj	272	11.7	Instrucciones de uso: Aclarado..	285
	7.2 Cómo ajustar: Funciones de reloj	273	11.8	Instrucciones de uso: Vaciado del depósito.....	286
8.	USO DE LOS ACCESORIOS.....	274	11.9	Cómo quitar e instalar: Puerta...	286
	8.1 Inserción de accesorios.....	274	11.10	Cómo cambiar: Bombilla.....	287
	8.2 Sonda térmica.....	275	12.	SOLUCIÓN DE PROBLEMAS.....	288
	8.3 Instrucciones de uso: Sonda térmica.....	275		12.1 Qué hacer si.....	289
9.	FUNCIONES ADICIONALES.....	277		12.2 Cómo administrar: Códigos de error.....	289
	9.1 Cómo guardar: Favoritos.....	277		12.3 Datos de servicio.....	290
	9.2 Bloqueo función.....	277	13.	EFICACIA ENERGÉTICA.....	290
	9.3 Desconexión automática.....	277		13.1 Información del producto y hoja de información del producto.....	290
	9.4 Ventilador de refrigeración.....	278		13.2 Ahorro energético.....	291
10.	CONSEJOS.....	278	14.	ESTRUCTURA DEL MENÚ.....	292
	10.1 Recomendaciones de cocción..	278		14.1 Menú.....	292
	10.2 Horneado húmedo + ventilador.	278		14.2 Submenú de: Limpieza.....	292
	10.3 Horneado húmedo + ventilador - accesorios recomendados.....	279		14.3 Submenú de: Opciones.....	293
	10.4 Tablas de cocción para organismos de control.....	280		14.4 Submenú de: Configuración.....	293
11.	MANTENIMIENTO Y LIMPIEZA.....	281		14.5 Submenú para: Asistencia.....	294
	11.1 Notas sobre la limpieza.....	281	15.	¡ES FÁCIL!.....	294
	11.2 Cómo quitar: Carriles de apoyo	282	16.	ASPECTOS MEDIOAMBIENTALES.....	295

1. INFORMACIÓN SOBRE SEGURIDAD

Antes de instalar y utilizar el aparato, lea atentamente las instrucciones facilitadas. El fabricante no se hace responsable de lesiones o daños producidos como resultado de una instalación o un uso incorrectos. Conserve siempre estas instrucciones en lugar seguro y accesible para futuras consultas.

1.1 Seguridad de niños y personas vulnerables

- Este aparato puede ser utilizado por niños de 8 años en adelante y personas cuyas capacidades físicas, sensoriales o mentales estén disminuidas o que carezcan de la experiencia y conocimientos suficientes para manejarlo, siempre que cuenten con las instrucciones o la supervisión sobre el uso del electrodoméstico de forma segura y comprendan los riesgos. Es necesario mantener alejados del aparato a los niños de menos de 8 años, así como a las personas con minusvalías importantes y complejas, salvo que estén bajo supervisión continua.
- Es necesario vigilar a los niños para que no jueguen con el aparato.
- Mantenga todo el material de embalaje fuera del alcance de los niños y deséchelo de forma adecuada.
- **ADVERTENCIA:** El horno y las piezas accesibles se calientan mucho durante el funcionamiento. Mantenga a los niños y las mascotas alejados del aparato cuando esté en uso y cuando se enfríe.
- Si este aparato tiene un bloqueo de seguridad para niños, debe activarlo.
- La limpieza y mantenimiento de usuario del producto no podrán ser realizados por niños sin supervisión.

1.2 Instrucciones generales de seguridad

- Este aparato está diseñado exclusivamente para cocinar.
- Este aparato está diseñado para uso doméstico en interiores.
- Este aparato se puede utilizar en oficinas, habitaciones de hotel, habitaciones de Bed&Breakfast, casas de campo y otros alojamientos similares donde dicho uso no exceda (en promedio) los niveles de uso doméstico.
- Solo un electricista cualificado puede instalar este aparato y sustituir el cable.

INFORMACIÓN SOBRE SEGURIDAD

- No utilice el aparato antes de instalarlo en la estructura empotrada.
- Desenchufe el aparato de la red eléctrica antes de realizar tareas de mantenimiento.
- Si el cable de alimentación sufre algún daño, el fabricante, su servicio técnico autorizado o un profesional tendrán que cambiarlo para evitar riesgos.
- **ADVERTENCIA:** Asegúrese de que el aparato está apagado antes de cambiar la bombilla para evitar el riesgo de descarga eléctrica.
- **ADVERTENCIA:** El horno y las piezas accesibles se calientan mucho durante el funcionamiento. Debe tener cuidado para evitar tocar los elementos de calentamiento o la superficie del interior del aparato.
- Utilizar siempre guantes o manoplas para horno para retirar o introducir accesorios o recipientes.
- Utilice únicamente la sonda térmica (la sonda de temperatura interna) recomendada para este aparato.
- Para retirar los carriles de apoyo, tire primero del frontal del carril y, a continuación, separe el extremo trasero de las paredes laterales. Instale los carriles de apoyo en el orden inverso.
- No utilice un limpiador a vapor para limpiar el aparato.
- No utilice productos de limpieza abrasivos ásperos ni rascadores de metal afilado para limpiar el cristal de las tapas abisagradas de la placa si no quiere arañar su superficie, lo que podría hacer que el cristal se hiciese añicos.
- Antes de la limpieza pirolítica, retirar todos los accesorios y cualquier depósito/derrames que haya en el interior del aparato.

2. INSTRUCCIONES DE SEGURIDAD

2.1 Instalación



ADVERTENCIA!

Sólo un técnico cualificado puede instalar el aparato.

- Retire todo el embalaje.
- No instale ni utilice un aparato dañado.
- Siga las instrucciones de instalación suministradas con el aparato.
- Tenga cuidado al mover el aparato, porque es pesado. Utilice siempre guantes de protección y calzado cerrado.
- No tire nunca del aparato sujetando el asa.
- Instale el aparato en un lugar seguro y adecuado que cumpla los requisitos de instalación.
- Respete siempre la distancia mínima entre el aparato y los demás electrodomésticos y mobiliario.
- Antes de montar el aparato, compruebe si la puerta se abre sin limitaciones.
- El aparato está equipado con un sistema de refrigeración eléctrica. Debe utilizarse con la fuente de alimentación eléctrica.
- La unidad empotrada debe cumplir los requisitos de estabilidad de la norma DIN 68930.

Altura mínima del armario (Altura mínima del armario debajo de la encimera)	578 (600) mm
Ancho del armario	560 mm
Profundidad del armario	550 (550) mm
Altura de la parte frontal del aparato	594 mm
Altura de la parte trasera del aparato	576 mm
Anchura de la parte frontal del aparato	595 mm
Anchura de la parte trasera del aparato	559 mm
Fondo del aparato	567 mm
Fondo empotrado del aparato	546 mm
Fondo con la puerta abierta	1027 mm
Tamaño mínimo de la abertura de ventilación. Abertura situada en la parte trasera inferior	560x20 mm
Longitud del cable de alimentación. El cable está en la esquina derecha de la parte trasera	1500 mm

INSTRUCCIONES DE SEGURIDAD

Tornillos de montaje	4x25 mm
----------------------	---------

2.2 Conexión eléctrica



ADVERTENCIA!

Riesgo de incendios y descargas eléctricas.

- Todas las conexiones eléctricas deben realizarlas electricistas cualificados.
- El aparato debe conectarse a tierra.
- Asegúrese de que los parámetros de la placa de características son compatibles con los valores eléctricos del suministro eléctrico.
- Utilice siempre una toma con aislamiento de conexión a tierra correctamente instalada.
- No utilice adaptadores de enchufes múltiples ni cables prolongadores.
- Asegúrese de no provocar daños en el enchufe ni en el cable de red. Si es necesario cambiar el cable de alimentación del aparato, debe hacerlo el centro de servicio técnico autorizado.
- Evite que el cable de red toque o entre en contacto con la puerta del aparato o con el hueco por debajo del aparato, especialmente mientras funciona o si la puerta está caliente.
- Los mecanismos de protección contra descargas eléctricas de componentes con corriente y aislados deben fijarse de forma que no puedan aflojarse sin utilizar herramientas.
- Conecte el enchufe a la toma de corriente únicamente cuando haya terminado la instalación. Asegúrese de tener acceso al enchufe del suministro de red una vez finalizada la instalación.
- Si la toma de corriente está floja, no conecte el enchufe.
- No desconecte el aparato tirando del cable de conexión a la red. Tire siempre del enchufe.
- Use únicamente dispositivos de aislamiento apropiados: línea con protección contra los cortocircuitos, fusibles (tipo tornillo que puedan retirarse del soporte), dispositivos de fuga a tierra y contactores.
- La instalación eléctrica debe tener un dispositivo de aislamiento que permita desconectar el aparato de todos los polos de la red. El dispositivo de aislamiento debe tener una apertura de contacto con una anchura mínima de 3 mm.
- Cierre completamente la puerta del aparato antes de enchufar el cable de alimentación a la toma de corriente.
- El aparato se suministra con enchufe y cable de red.

2.3 Uso



ADVERTENCIA!

Riesgo de lesiones, quemaduras y descargas eléctricas o explosiones.

- No cambie las especificaciones de este aparato.
- Asegúrese de que las aberturas de ventilación no están bloqueadas.
- No deje el aparato desatendido durante el funcionamiento.
- Apague el aparato después de cada uso.
- Tenga cuidado al abrir la puerta del aparato mientras funciona. Puede liberarse aire caliente.
- No utilice el aparato con las manos mojadas ni con agua en contacto.
- No ejerza presión sobre la puerta abierta.
- No utilice el aparato como superficie de trabajo ni para depositar objetos.

- Abra la puerta del aparato con cuidado. El uso de ingredientes con alcohol puede provocar una mezcla de alcohol y aire.
- No deje que los chispas ni las llamas abiertas entren en contacto con el aparato cuando abra la puerta.
- No coloque productos inflamables o artículos mojados con productos inflamables dentro, cerca o sobre el aparato.

**ADVERTENCIA!**

Podría dañar el aparato.

- Para evitar daños o decoloraciones en el esmalte:
 - no coloque recipientes ni otros objetos directamente en la base.
 - no coloque papel de aluminio directamente en la parte inferior del interior del aparato.
 - no ponga agua directamente en el aparato caliente.
 - no deje platos húmedos ni alimentos en el aparato una vez finalizada la cocción.
 - tenga cuidado al retirar o instalar los accesorios.
- La pérdida de color del esmalte o el acero inoxidable no afecta al rendimiento del aparato.
- Utilice una bandeja honda para pasteles húmedos. Los jugos de las frutas provocan manchas permanentes.
- Cocine siempre con la puerta del aparato cerrada.
- Si el aparato se instala detrás de un panel de un mueble (por ejemplo una puerta) asegúrese de que la puerta nunca esté cerrada mientras funciona el aparato. El calor y la humedad pueden acumularse detrás de un panel del armario cerrado y provocar daños al aparato, el alojamiento o el suelo. No cierre del panel del armario hasta que el aparato se haya enfriado completamente después de su uso.

2.4 Mantenimiento y limpieza

**ADVERTENCIA!**

Existe riesgo de lesiones, incendios o daños al aparato.

- Antes de proceder con el mantenimiento, apague el aparato y desconecte el enchufe de la red.
- Asegúrese de que el aparato esté frío. Los paneles de cristal pueden romperse.
- Cambie inmediatamente los paneles de cristal de la puerta que estén dañados. Póngase en contacto con el servicio técnico autorizado.
- Tenga cuidado al desmontar la puerta del aparato. ¡La puerta es muy pesada!
- Limpie periódicamente el aparato para evitar el deterioro del material de la superficie.
- Limpie el aparato con un paño suave humedecido. Utilice solo detergentes neutros. No utilice productos abrasivos, estropajos duros, disolventes ni objetos metálicos.
- Si utiliza aerosoles de limpieza para hornos, siga las instrucciones de seguridad del envase.

2.5 Limpieza Piroclítica

**ADVERTENCIA!**

Riesgo de lesiones / Incendios / Emisiones químicas (humos) en el modo piroclítico.

- Antes de realizar la limpieza piroclítica y el precalentamiento inicial, retire del interior del horno:
 - restos de comida, aceite o grasa o depósitos.
 - cualquier objeto extraíble (incluidos estantes, rieles laterales, etc., suministrados con el aparato), especialmente cualquier olla, sartén, bandeja, utensilio, etc. antiadherente.

INSTRUCCIONES DE SEGURIDAD

- Lea atentamente todas las instrucciones de limpieza pirolítica.
- Mantenga a los menores alejados del aparato cuando se realiza la limpieza pirolítica. El aparato se calienta mucho y el aire caliente se expulsa por las salidas de ventilación delanteras.
- La limpieza pirolítica es una operación a alta temperatura que puede liberar humos de los residuos de cocción y de los materiales de fabricación, por lo que se recomienda a los consumidores:
 - proporcionar una buena ventilación durante y después de la limpieza pirolítica.
 - proporcionar una buena ventilación durante y después del precalentamiento inicial.
- No derrame ni aplique agua a la puerta del horno durante y después de la limpieza pirolítica para no provocar daños en los paneles de vidrio.
- Los humos emitidos por todos los hornos pirolíticos y residuos de cocción descritos no son dañinos para las personas, incluidos los niños o personas con problemas médicos.
- Mantenga las mascotas pequeñas alejadas del aparato durante y después de la limpieza pirolítica y precalentamiento inicial. Las mascotas pequeñas (especialmente las aves y los reptiles) pueden ser muy sensibles a los cambios de temperatura y los humos emitidos.
- Las superficies antiadherentes de recipientes, sartenes, bandejas, utensilios, etc., pueden dañarse por la alta temperatura pirolítica de todos los hornos pirolíticos y también pueden ser fuente de humos dañinos de baja intensidad.

2.6 Cocción al vapor



ADVERTENCIA!

Existe riesgo de lesiones y daños en el aparato.

- El vapor liberado puede causar quemaduras:
 - Tenga cuidado al abrir la puerta del aparato cuando la función esté activada. Pueden liberarse vapores.
 - Abra la puerta del aparato con cuidado después del funcionamiento de la cocción al vapor.

2.7 Iluminación interna



ADVERTENCIA!

Riesgo de descarga eléctrica.

- En cuanto a la(s) bombilla(s) de este producto y las de repuesto vendidas por separado: Estas bombillas están destinadas a soportar condiciones físicas extremas en los aparatos domésticos, como la temperatura, la vibración, la humedad, o están destinadas a señalar información sobre el estado de funcionamiento del aparato. No están destinadas a utilizarse en otras aplicaciones y no son adecuadas para la iluminación de estancias domésticas.
- Este producto contiene una fuente luminosa de la clase de eficiencia energética G.
- Utilice solo bombillas de las mismas características .

2.8 Asistencia técnica

- Para reparar el aparato, póngase en contacto con el centro de servicio autorizado.
- Utilice solamente piezas de recambio originales.

2.9 Eliminación



ADVERTENCIA!

Existe riesgo de lesiones o asfixia.

- Contacte con las autoridades locales para saber cómo desechar correctamente el aparato.
- Desconecte el aparato de la red.
- Corte el cable eléctrico cerca del aparato y deséchelo.
- Retire el pestillo de la puerta para evitar que los niños o las mascotas queden atrapados en el aparato.

3. DESCRIPCIÓN DEL PRODUCTO

3.1 Resumen general

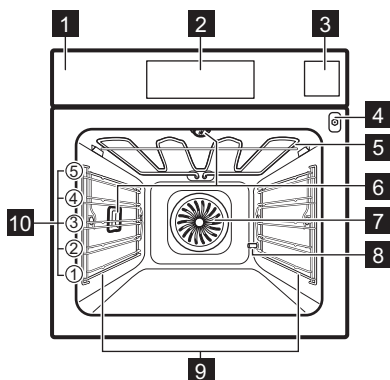

- 1 Panel de control
- 2 Pantalla
- 3 Compartimento de agua
- 4 Toma de la sonda térmica
- 5 Resistencia
- 6 Bombilla
- 7 Ventilador
- 8 Descalcificación de tubo de salida
- 9 Soporte de parrilla extraíble
- 10 Posiciones de las parrillas

3.2 Accesorios

Parrilla

Para utensilios de cocina, moldes de pastelería, asados.

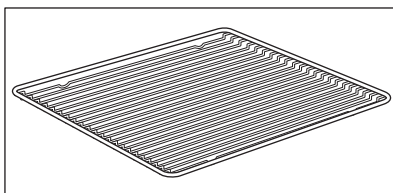

Bandeja

Para bizcochos y galletas.

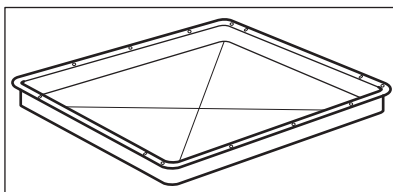

PANEL DE MANDOS

Parrilla/sartén para asar

Para hornear y asar o como bandeja para grasa.

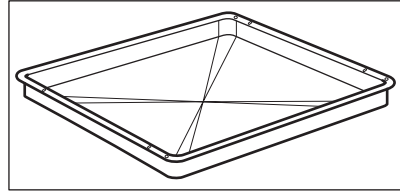

Sonda térmica

Para medir la temperatura interior de los alimentos.

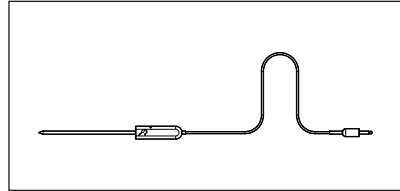

4. PANEL DE MANDOS

4.1 Vista general del panel de control

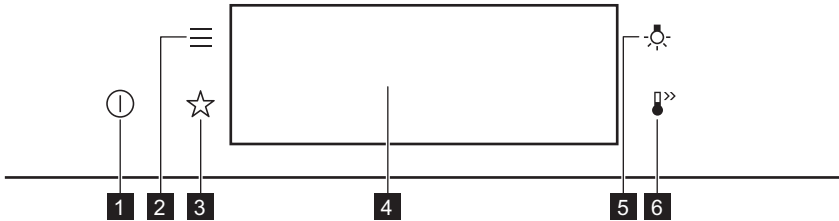







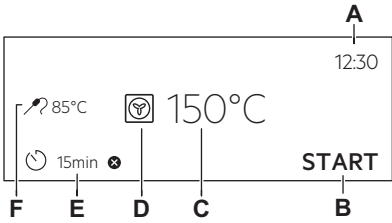

1	Encendido/ON / Apagado/OFF	Mantenga pulsado para encender y apagar el aparato.
2	Menú	Muestra las funciones del aparato.
3	Favoritos	Muestra los ajustes favoritos.
4	Pantalla	Muestra los ajustes actuales del electrodoméstico.
5	Interruptor de la lámpara	Enciende y apaga la luz.
6	Calentamiento rápido	Para activar y desactivar la función: Calentamiento rápido.

 <p>Pulse el botón</p>	 <p>Mover</p>	 <p>Mantener pulsado</p>
<p>Touchar la superficie con la punta de los dedos.</p>	<p>Deslizar la punta del dedo sobre la superficie.</p>	<p>Touchar la superficie durante 3 segundos.</p>

4.2 Pantalla

	<p>Pantalla con conjunto de funciones clave.</p> <ul style="list-style-type: none"> A. Hora B. INICIO/PARAR C. Temperatura D. Funciones de cocción E. Temporizador F. Sonda térmica (solo en modelos seleccionados)
-----------------------------------------------------------------------------------	---------------------------------------------------------------------------------------------------------------------------------------------------------------------------------------------------------------------------------------------------------------------------------

Indicadores de pantalla

<p>Indicadores básicos - para navegar por la pantalla.</p>			
<p>OK</p> <p>Para confirmar la selección o el ajuste.</p>	 <p>Para retroceder un nivel en el menú.</p>	 <p>Para deshacer la última acción.</p>	 <p>Para activar y desactivar las opciones.</p>
<p>Sonar la alarma indicadores de función - cuando finaliza el tiempo de cocción seleccionado, suena una señal acústica.</p>			
 <p>La función está activada.</p>	 <p>La función está activada. La cocción se detiene automáticamente.</p>	 <p>El sonido de la alarma está apagado.</p>	
<p>Indicadores de temporizador</p>			
 <p>Para ajustar la función: Inicio retardado.</p>	 <p>Para cancelar el ajuste.</p>		

5. ANTES DEL PRIMER USO



ADVERTENCIA!

Consulte los capítulos sobre seguridad.

5.1 Limpieza inicial

Paso 1	Paso 2	Paso 3
Retire todos los accesorios y carriles laterales extraíbles del aparato.	Limpie únicamente el aparato y los accesorios con un paño de microfibra humedecido en agua tibia y detergente suave.	Coloque los accesorios y carriles de apoyo extraíbles en el aparato.



5.2 Primera conexión

La pantalla muestra un mensaje de bienvenida después de la primera conexión.

Debe ajustar: Idioma, Brillo de la pantalla, Tono de teclas, Volumen del timbre, Dureza del agua, Hora.

5.3 Pre calentamiento inicial





Pre caliente el horno vacío antes de utilizarlo por primera vez.

Paso 1	Retire todos los accesorios del horno y carriles laterales extraíbles del horno.
Paso 2	Seleccione la temperatura máxima para la función:  . Deje funcionar el horno 1 hora.
Paso 3	Seleccione la temperatura máxima para la función:  . Deje funcionar el horno 15 minutos.





 El horno puede emitir olores y humos durante el pre calentamiento. Asegúrese de que la sala esté ventilada.

5.4 Cómo ajustar: Dureza del agua

Cuando conecte el horno a la corriente eléctrica, deberá ajustar el nivel de dureza del agua. Use el test reactivo o póngase en contacto con su proveedor de agua para conocer el nivel de dureza del agua.

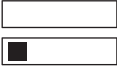
			
Paso 1	Paso 2	Paso 3	Paso 4
<p>Introduzca el test reactivo en el agua durante aproximadamente 1 segundo. No ponga el test reactivo bajo el grifo.</p>	<p>Agite el test reactivo para eliminar el exceso de agua.</p>	<p>Tras 1 minuto, compruebe la dureza del agua de acuerdo con la siguiente tabla.</p>	<p>Ajuste el nivel de dureza del agua: Menú / Ajustes / Configuración / Dureza del agua.</p>
<p>i Los colores del test reactivo seguirán cambiando. No verifique la dureza del agua más de 1 un minuto después de la prueba.</p>			
<p>Puede cambiar el nivel de dureza del agua en el menú: Ajustes / Configuración / Dureza del agua.</p>			

En la tabla se muestra el rango de dureza del agua (dH) junto con el nivel correspondiente de depósito de calcio y la clasificación del agua. Ajuste el nivel de dureza del agua de acuerdo con la tabla.

Dureza del agua		Test reactivo	Depósito de calcio (mmol/l)	Depósito de calcio (mg/l)	Clasificación del agua
Nivel	dH				
1	0 - 7		0 - 1.3	0 - 50	blanda
2	8 - 14		1.4 - 2.5	51 - 100	intermedia
3	15 - 21		2.6 - 3.8	101 - 150	dura
4	≥ 22		≥ 3.9	≥ 151	muy dura

Cuando el nivel de dureza del agua sea 4, llene el compartimento de agua con agua embotellada.

6. USO DIARIO





ADVERTENCIA!

Consulte los capítulos sobre seguridad.

6.1 Cómo ajustar: Funciones de cocción

Paso 1	Encienda el horno. La pantalla muestra la función de cocción por defecto.
Paso 2	Pulse el símbolo de la función de cocción para entrar en el submenú.
Paso 3	Seleccione la función de cocción y pulse: OK . La pantalla muestra: temperatura.
Paso 4	Ajuste: temperatura. Pulse: OK .
Paso 5	Pulse: START . Sonda térmica - puede conectar la sonda en cualquier momento antes o durante la cocción.
STOP - pulse para desactivar la función de cocción.	
Paso 6	Apague el horno.

6.2 Cómo ajustar: Función de cocción al vapor

Paso 1	Encienda el horno. Seleccione el símbolo de la función de cocción y púselo para entrar en el submenú.
Paso 2	Pulse  . Ajuste la función de cocción al vapor.
Paso 3	Pulse: OK . La pantalla muestra los ajustes de temperatura.
Paso 4	Ajuste la temperatura.
Paso 5	Pulse: OK .
Paso 6	Presione la tapa del compartimento de agua para abrirla.
Paso 7	Llene el depósito de agua con agua fría hasta el nivel máximo (unos 950 ml) hasta que suene la señal o aparezca el mensaje en la pantalla. No llene el compartimento de agua por encima de su capacidad máxima. Existe el riesgo de fuga de agua, derrames y daños al mobiliario.  ADVERTENCIA! Utilice únicamente agua fría del grifo. No utilice agua filtrada (desmineralizada) ni destilada. No utilice otros líquidos. No vierta líquidos inflamables o con alcohol en el compartimento de agua.

Paso 8	Empuje el compartimento de agua hasta su posición inicial.
Paso 9	Pulse: START . El vapor aparece después de aproximadamente 2 minutos. Cuando el horno alcanza la temperatura establecida, suena la señal.
Paso 10	Una señal acústica avisa de que el compartimento de agua se queda sin agua. Rellene el compartimento de agua.
Paso 11	Apague el horno.
Paso 12	Vacíe el compartimento de agua después de cada cocción. Consulte el capítulo "Mantenimiento y limpieza", Vaciado del depósito.
Paso 13	El agua residual puede condensarse en el interior. Después de cocinar, tenga cuidado siempre que abra la puerta del horno. Cuando el horno este frío, seque el interior con un paño suave.

6.3 Cómo configurar: Cocción asistida



Para cada plato de este submenú se recomienda una función y temperatura. Puede ajustar el tiempo y la temperatura.

Para algunos de los platos, también puede cocinar con:

- Peso automático
- Sonda térmica









El grado de cocinado de un plato:

- Poco hecho o Menos
- Al punto
- Muy hecho o Muy hecho









Paso 1	Encienda el horno.
Paso 2	Pulse:  .
Paso 3	Pulse:  . Introduzca: Cocción asistida.
Paso 4	Elija un tipo de plato o comida.
Paso 5	Pulse: START .

6.4 Funciones de cocción

ESTÁNDAR



Función de cocción	Aplicación
 Grill	Para asar al grill alimentos de poco espesor y tostar pan.
 Grill turbo	Asado con aire caliente para piezas de carne más grandes o aves con hueso en un nivel. Para gratinar y dorar.
 Aire caliente	Para hornear en hasta tres posiciones de parrilla a la vez y para secar alimentos. Ajuste la temperatura entre 20 y 40°C menos que para Cocción convencional.
 Congelados	Para productos precocinados (por ejemplo, patatas fritas, porciones de patata o rollitos de primavera) crujientes.
 Cocción convencional	Para hornear y asar alimentos en una posición de parrilla.
 Función Pizza	Para hornear pizza. Para obtener un dorado más intenso y una base más crujiente.
 Calor inferior	Para hornear pasteles con base crujiente y conservar alimentos.
 Leudar masas	Para acelerar el levado de la masa de levadura. Evita que la superficie de la masa se reseque y mantiene su elasticidad.

PLATOS ESPECIALES

Función de cocción	Aplicación
 Conservar	Para conservar verduras (p.ej. encurtidos).
 Desecar alimentos	Para secar rodajas de fruta, verduras y champiñones.
 Calientaplatos	Para precalentar platos para servir.
 Descongelar	Para descongelar alimentos (verduras y frutas). El tiempo de descongelación depende de la cantidad y el tamaño de los alimentos congelados.
 Gratinar	Para platos como lasañas o patatas gratinadas. Para gratinar y dorar.
 Cocción lenta	Para preparar asados tiernos y jugosos.
 Mantener Caliente	Para mantener calientes los alimentos.
 Horneado húmedo + ventilador	Función diseñada para ahorrar energía durante la cocción. Cuando se utiliza esta función, la temperatura del horno puede diferir de la temperatura programada. Se utiliza el calor residual. La potencia calorífica puede reducirse. Para más información, consulte el capítulo "Uso diario", Notas sobre: Horneado húmedo + ventilador.

FUNCIONES DEL RELOJ

VAPOR

Función de cocción	Aplicación
 Regenerar con vapor	El recalentamiento de los alimentos con vapor evita que se reseque su superficie. El calor se distribuye de forma suave y uniforme, recuperando el sabor y el aroma de los alimentos como si estuvieran recién hechos. Esta función se puede usar para recalentar alimentos directamente en el plato. Puede recalentar más de un plato al mismo tiempo usando diferentes niveles.
 Horneado de pan	Use esta función para preparar pan y rollitos con resultados profesionales y conseguir alimentos crujientes y dorados.
 Humedad baja	Esta función es adecuada para carne, aves, platos al horno y estofados. Gracias a la combinación de vapor y calor, la carne queda más tierna y jugosa, con una superficie crujiente.

6.5 Notas sobre: Horneado húmedo + ventilador

Esta función se utilizaba para cumplir con los requisitos de eficiencia energética y diseño ecológico (según EU 65/2014 y EU 66/2014). Pruebas según: IEC/EN 60350-1

La puerta del horno debe estar cerrada durante la cocción para que no se interrumpa la función y el horno funcione con la máxima eficiencia energética posible.

Cuando se utiliza esta función, la lámpara se apaga automáticamente después de 30 s.

Consulte las instrucciones de cocción en el capítulo "Consejos", Horneado húmedo + ventilador. Para recomendaciones generales sobre ahorro energético, consulte el capítulo "Eficiencia energética", ahorro energético.

7. FUNCIONES DEL RELOJ

7.1 Descripción de funciones de reloj

Función de reloj	Aplicación
Tiempo de cocción	Para ajustar la duración de la cocción. El máximo es 23 h 59 min.
Finalizar acción	Para ajustar lo que ocurre al finalizar el temporizador.
Inicio retardado	Para posponer el inicio y/o fin de la cocción.
Añadir tiempo	Para ampliar el tiempo de cocción.

Función de reloj	Aplicación
Avisador	Para ajustar una cuenta atrás. El máximo es 23 h 59 min. Esta función no influye en el funcionamiento del aparato.
Tiempo de funcionamiento	Controla el tiempo que está activa la función. Tiempo de funcionamiento : puede encenderla y apagarla.

7.2 Cómo ajustar: Funciones de reloj

Cómo ajustar el reloj	
Paso 1	Pulse: Hora.
Paso 2	Ajuste la hora. Pulse: OK.

Cómo programar el tiempo de cocción	
Paso 1	Elija la función de cocción y la temperatura.
Paso 2	Pulse:  .
Paso 3	Ajuste la hora. Pulse: OK.

Cómo elegir la opción de final	
Paso 1	Elija la función de cocción y la temperatura.
Paso 2	Pulse:  .
Paso 3	Ajuste el tiempo de cocción.
Paso 4	Pulse: ● ● ● .
Paso 5	Pulse: Finalizar acción.
Paso 6	Elija el que prefiera: Finalizar acción.
Paso 7	Pulse: OK. Repita la acción hasta que la pantalla muestre la pantalla principal.

USO DE LOS ACCESORIOS

Cómo retrasar el inicio de la cocción

Paso 1	Ajuste la función de cocción y la temperatura.
Paso 2	Pulse:  .
Paso 3	Ajuste el tiempo de cocción.
Paso 4	Pulse: ● ● ● .
Paso 5	Pulse: Inicio retardado.
Paso 6	Elija el valor.
Paso 7	Pulse: OK. Repita la acción hasta que la pantalla muestre la pantalla principal.

Cómo prolongar el tiempo de cocción

Cuando queda el 10% del tiempo de cocción y parece que la comida no está lista, puede extender el tiempo de cocción. También puede cambiar la función de cocción.

Para prolongar el tiempo de cocción, pulse **+1min.**

Cómo cambiar los ajustes del temporizador

Paso 1	Pulse:  .
Paso 2	Ajuste el valor del temporizador.
Paso 3	Pulse: OK.

Puede cambiar el tiempo ajustado durante la cocción en cualquier momento.

8. USO DE LOS ACCESORIOS



ADVERTENCIA!

Consulte los capítulos sobre seguridad.

8.1 Inserción de accesorios

Una pequeña muesca en la parte superior aumenta la seguridad. Las hendiduras también son dispositivos antivuelco. El borde elevado que rodea la bandeja evita que los utensilios de cocina resbalen de la parrilla.

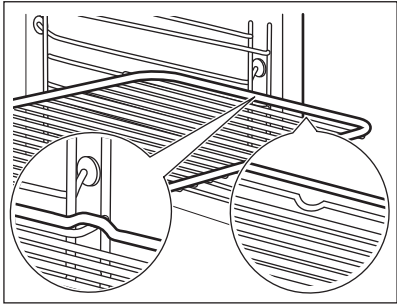
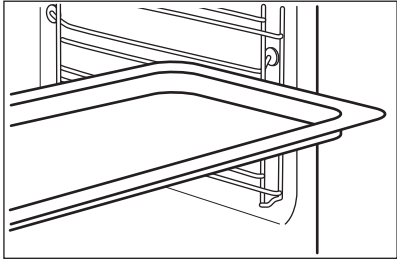
<p>Parrilla: Inserte la parrilla entre las guías del carril.</p>	
<p>Bandeja / Bandeja honda: Introduzca la bandeja entre las guías del carril de apoyo.</p>	

8.2 Sonda térmica

Sonda térmica: mide la temperatura dentro de los alimentos. Puede utilizarse con cualquier otra función de cocción.

Debe ajustar dos temperaturas:	
<p style="text-align: center;">°C</p> <p>La temperatura del horno: mínimo 120°C.</p>	<p style="text-align: center;"></p> <p>La temperatura interna.</p>



Para obtener un resultado de cocción óptimo:		
<p>Los ingredientes deben estar a temperatura ambiente.</p>	<p>No debe utilizarse para platos líquidos.</p>	<p>Durante la cocción debe permanecer en el plato.</p>

El horno calcula una hora final aproximada para la cocción. Esta hora dependerá de la cantidad de alimentos, de la función de horno programada y de la temperatura.

8.3 Instrucciones de uso: Sonda térmica

<p>Paso 1</p>	<p>Encienda el horno.</p>
----------------------	---------------------------

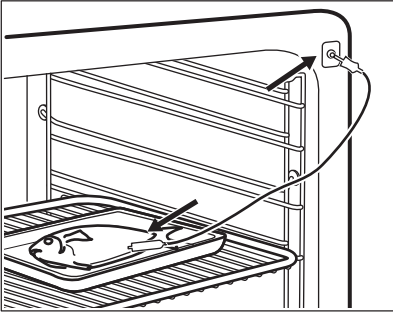
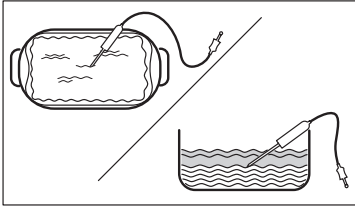
USO DE LOS ACCESORIOS



Paso 2	Programe una función de cocción y, si es necesario, la temperatura del horno.	
Paso 3	Introduzca: Sonda térmica.	
Carne, aves y pescado	Estofado	
<p>Inserte la punta de Sonda térmica en el centro de la carne o el pescado, en la parte más gruesa si es posible. Asegúrese de que al menos 3/4 de Sonda térmica queda dentro del plato.</p>	<p>Inserte la punta de Sonda térmica exactamente en el centro del estofado. Sonda térmica debe mantenerse estable en un lugar durante el horneado. Para ello, úsela con un alimento sólido. Use el borde de la fuente de horno para apoyar el asa de silicona de Sonda térmica. La punta de Sonda térmica no debe tocar el fondo de la fuente de horno.</p>	
		
Paso 4	Enchufe Sonda térmica en la toma de la parte frontal del horno. La pantalla muestra la temperatura actual de: Sonda térmica.	
Paso 5	 - pulse para ajustar la temperatura interna de la sonda.	
Paso 6	<ul style="list-style-type: none"> ● ● ● - pulse para ajustar la opción preferida: • Sonar la alarma - cuando los alimentos alcanzan la temperatura interna, suena una señal acústica. • Sonar la alarma y parar de cocinar - cuando los alimentos alcanzan la temperatura interna, suena una señal acústica y finaliza la cocción. 	
Paso 7	Seleccione la opción y pulse varias veces: OK para ir a la pantalla principal.	
Paso 8	<p>Pulse: START .</p> <p>Cuando los alimentos alcancen la temperatura programada, sonará una señal acústica. Puede finalizar o continuar la cocción para asegurarse de que los alimentos estén correctamente cocinados.</p>	

Paso 9	<p>Desconecte Sonda térmica el enchufe de la toma y saque el plato del horno.</p> <div style="border: 1px solid black; padding: 5px; margin-top: 10px;">  <p>ADVERTENCIA! Existe riesgo de quemaduras Sonda térmica al calentarse. Tenga mucho cuidado al desconectarla y retirarla del alimento.</p> </div>
---------------	----------------------------------------------------------------------------------------------------------------------------------------------------------------------------------------------------------------------------------------------------------------------------------------------------------------------------------------------------------------------------------------------------------

9. FUNCIONES ADICIONALES



9.1 Cómo guardar: Favoritos

Puede guardar sus ajustes favoritos, como la función de cocción, el tiempo de cocción, la temperatura o la función de limpieza. Puede guardar 3 ajustes favoritos.

Paso 1	Ponga en marcha el aparato.
Paso 2	Seleccione los ajustes preferidos.
Paso 3	Pulse:  . Seleccione: Favoritos.
Paso 4	Seleccione: Guardar los ajustes actuales.
Paso 5	Pulse + para añadir el ajuste a la lista de: Favoritos. Pulse OK.
<p> - pulse para restablecer el ajuste.</p> <p> - pulse para cancelar el ajuste.</p>	



9.2 Bloqueo función

Esta función impide que se produzca accidentalmente un cambio de la función de cocción.

Paso 1	Ponga en marcha el aparato.
Paso 2	Seleccione una función de cocción.
Paso 3	 ,  - pulse al mismo tiempo para activar la función.
Para desactivar la función, repita el paso 3.	

9.3 Desconexión automática

Por motivos de seguridad, el aparato se desactiva transcurrido un tiempo si una función de cocción está en funcionamiento y no se modifica ningún ajuste.

 (°C)	 (h)
30 - 115	12.5
120 - 195	8.5
200 - 245	5.5
250 - máximo	3

La función de desconexión automática no funciona con las siguientes funciones: Luz, Sonda térmica, Hora de fin, Cocción lenta.

9.4 Ventilador de refrigeración

Cuando el aparato está en funcionamiento, el ventilador de enfriamiento se enciende automáticamente para mantener frías sus superficies. Si apaga el aparato, el ventilador de enfriamiento puede seguir funcionando hasta que se enfríe.

10. CONSEJOS





10.1 Recomendaciones de cocción



La temperatura y los tiempos de cocción de las tablas son meramente orientativos. Dependen de las recetas y de la calidad y cantidad de los ingredientes utilizados. El aparato puede hornear o asar de forma diferente del aparato que tenía anteriormente. Las siguientes sugerencias muestran los ajustes recomendados para la temperatura, el tiempo de cocción y la posición de los estantes para tipos de alimentos concretos. Si no encuentra los ajustes para una receta especial, busque otra similar. Para más recomendaciones de cocina, consulte las tablas de cocción en nuestro sitio web. Para encontrar los consejos de cocción, compruebe el número de PNC de la placa de datos del marco frontal del interior del aparato.



10.2 Horneado húmedo + ventilador

Para obtener el mejor resultado, siga las recomendaciones de la tabla siguiente.

		 (°C)		 (min)
Rollitos dulces, 16 piezas	bandeja o bandeja honda	180	2	25 - 35
Brazo de gitano	bandeja o bandeja honda	180	2	15 - 25
Pescado entero, 0,2 kg	bandeja o bandeja honda	180	3	15 - 25
Galletas, 16 piezas	bandeja o bandeja honda	180	2	20 - 30
Mostachones de almendra, 24 piezas	bandeja o bandeja honda	160	2	25 - 35
Muffins, 12 piezas	bandeja o bandeja honda	180	2	20 - 30
Tarta salada, 20 piezas	bandeja o bandeja honda	180	2	20 - 30
Galletas crujientes de masa quebrada, 20 piezas	bandeja o bandeja honda	140	2	15 - 25
Tartaletas, 8 piezas	bandeja o bandeja honda	180	2	15 - 25

10.3 Horneado húmedo + ventilador - accesorios recomendados

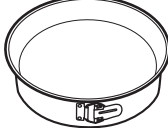
Utilice molde y recipientes oscuros y mates. Tiene mejor absorción del calor que los platos de color claro y brillantes.

			
Bandeja para pizza	Bandeja para hornear	Ramequines	Molde para base





Oscuro, mate 28 cm de diámetro	Oscuro, mate 26 cm de diámetro	Cerámica 8 cm de diámetro, 5 cm de altura	Oscuro, mate 28 cm de diámetro
-----------------------------------	-----------------------------------	----------------------------------------------	-----------------------------------

10.4 Tablas de cocción para organismos de control

Información para institutos de pruebas





Pruebas según: EN 60350, IEC 60350.

Horneado en un nivel: hornear en moldes





		 °C	 min	
Bizcocho sin grasa	Aire caliente	160	45 - 60	2
Bizcocho sin grasa	Cocción convencional	160	45 - 60	2
Tarta de manzana, 2 moldes, Ø 20 cm	Aire caliente	160	55 - 65	2
Tarta de manzana, 2 moldes, Ø 20 cm	Cocción convencional	180	55 - 65	1
Mantecados	Aire caliente	140	25 - 35	2
Mantecados	Cocción convencional	140	25 - 35	2

Horneado en un nivel: galletas

Use el tercer nivel.

		 °C	 min
Pastelillos, 20 unidades por bandeja, precaliente el horno vacío	Aire caliente	150	20 - 30
Pastelillos, 20 unidades por bandeja, precaliente el horno vacío	Cocción convencional	170	20 - 30





Horneado multinivel: galletas

		 °C	 min	
Mantecados	Aire caliente	140	25 - 45	2 / 4
Pastelillos, 20 unidades por bandeja, precaliente el horno vacío	Aire caliente	150	25 - 35	1 / 4
Bizcocho sin grasa	Aire caliente	160	45 - 55	2 / 4
Pastel de manzana, 1 molde por rejilla (Ø 20 cm)	Aire caliente	160	55 - 65	2 / 4

Grill

Precaliente el horno vacío durante 5 minutos.

Grill con la temperatura ajustada al máximo.

		 min	
Tostadas	Grill	1 - 2	5
Bistec de vacuno, dar la vuelta a media cocción	Grill	24 - 30	4

11. MANTENIMIENTO Y LIMPIEZA



ADVERTENCIA!

Consulte los capítulos sobre seguridad.

11.1 Notas sobre la limpieza

 Agentes limpiadores	Limpie la parte frontal del aparato solo con un paño de microfibra humedecido en agua tibia y detergente suave.
	Utilice un producto de limpieza para limpiar las superficies metálicas.
	Limpie las manchas con un detergente suave.

MANTENIMIENTO Y LIMPIEZA

 Uso diario	Limpie el interior después de cada uso. La acumulación de grasa u otros residuos puede provocar un incendio.
	No guarde la comida en el aparato más de 20 minutos. Seque la cavidad solo con un paño de microfibra después de cada uso.

 Accesorios	Limpie todos los accesorios después de cada uso y déjelos secar. Use solo un paño suave humedecido en agua tibia y detergente suave. No lave los accesorios en el lavavajillas.
	Evite limpiar los accesorios antiadherentes con limpiadores abrasivos u objetos afilados.

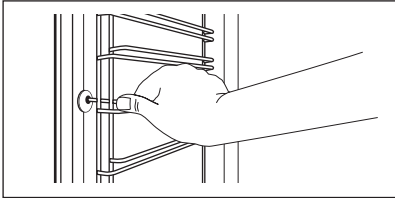

11.2 Cómo quitar: Carriles de apoyo

Para limpiar el horno, retire los carriles de apoyo.

Paso 1	Apague el horno y espere a que esté frío.	
Paso 2	Tire con cuidado de los soportes hacia arriba y hacia afuera del tope delantero.	
Paso 3	Tira del extremo delantero del carril de apoyo para separarlo de la pared lateral.	
Paso 4	Extrae los carriles de la sujeción posterior.	
Instale los carriles de apoyo en el orden inverso.		

11.3 Instrucciones de uso: Limpieza pirolítica

Limpie el horno con Limpieza pirolítica.

	ADVERTENCIA! Existe riesgo de quemaduras.
	PRECAUCIÓN! Si hay otros aparatos instalados en el mismo armario, no los utilice al mismo tiempo que esta función. El horno podría dañarse.

Antes de Limpieza pirolítica:

Apague el horno y espere a que esté frío.	Retire todos los accesorios del horno.	Limpie el suelo del horno y la puerta interior de cristal con agua templada, un paño suave y detergente suave.
-------------------------------------------	----------------------------------------	----------------------------------------------------------------------------------------------------------------

No rellene el depósito de agua durante la limpieza. Reinicia el ciclo de limpieza.

Paso 1	Encienda el horno.
Paso 2	Pulse:  / Limpieza.
Paso 3	Coloque la bandeja en la primera posición para recoger el agua del depósito. OK - pulse para comenzar el vaciado del depósito de agua.
Paso 4	Cuando termine el vaciado del depósito, retire la bandeja y los carriles laterales extraíbles. Limpie el interior del horno y el cristal interior de la puerta con un paño suave. Pulse: OK.
Paso 5	Seleccione el modo de limpieza.

Opción	Modo de limpieza	Duración
Limpieza pirolítica, rápida	Limpieza ligera	1 h
Limpieza pirolítica, normal	Limpieza normal	1 h 30 min
Limpieza pirolítica, intensa	Limpieza a fondo	3 h

 Cuando comienza la limpieza, la bombilla está apagada y el ventilador de refrigeración funciona a mayor velocidad.

STOP - pulse para parar la limpieza antes de que termine.

No utilice el horno hasta que el símbolo de bloqueo de puerta desaparezca de la pantalla.

Cuando termina la limpieza:

Apague el horno y espere a que esté frío.	Seque el interior con un paño suave.	Retire los residuos de la parte inferior del interior.
-------------------------------------------	--------------------------------------	--------------------------------------------------------

11.4 Aviso de limpieza

Se recomienda limpiar cuando aparece el aviso.
Use la función: Limpieza pirolítica.

11.5 Instrucciones de uso: Descalcificación

Antes de empezar:		
Apague el horno y espere a que esté frío.	Retire todos los accesorios.	Asegúrese de que el compartimento de agua está vacío.

Duración de la primera parte: unos 100 minutos	
Paso 1	Coloque la bandeja honda en la primera posición.
Paso 2	Añada 250 ml de descalcificador al compartimento de agua.
Paso 3	Vierta agua en el compartimento de agua hasta alcanzar el nivel máximo, hasta que suene la señal o aparezca el mensaje en la pantalla.
Paso 4	Seleccione: Menú / Limpieza.
Paso 5	Active la función y siga las instrucciones de la pantalla. Se inicia la primera parte de la descalcificación.
Paso 6	Cuando finalice la primera parte, vacíe la bandeja honda y vuelva a colocarla en el primer nivel.
Duración de la segunda parte: unos 35 minutos	
Paso 7	Vierta agua en el compartimento de agua hasta alcanzar el nivel máximo, hasta que suene la señal o aparezca el mensaje en la pantalla.
Paso 8	Cuando la función finalice, retire la bandeja honda.
 Cuando esta función está activa, la luz está apagada.	

Cuando finalice la descalcificación:

Apague el horno.	Cuando el horno este frío, seque el interior con un paño suave.	Deje la puerta del horno abierta y espere a que el interior esté seco.
<p>i Si queda algún residuo de cal en el horno después de la descalcificación, la pantalla indicará que se debe repetir el procedimiento.</p>		

11.6 Avisador para descalcificación

Hay dos recordatorios que le recuerdan que descalcifique el horno. El avisador de descalcificación no puede desactivarse.

Variedad	Descripción
Avisador suave	Recomienda que descalcifique el horno.
Avisador fijo	Obliga a descalcificar el horno. Si no descalcifica el aparato cuando el avisador fijo está activo, las funciones de vapor se desactivan.

11.7 Instrucciones de uso: Aclarado

Antes de empezar:

Apague el horno y espere a que esté frío.	Retire todos los accesorios.
-------------------------------------------	------------------------------

Paso 1	Coloque la bandeja honda en la primera posición.
Paso 2	Vierta agua en el compartimento de agua hasta alcanzar el nivel máximo, hasta que suene la señal o aparezca el mensaje en la pantalla.
Paso 3	Selección: Menú / Limpieza / Aclarado. Duración: unos 30 minutos
Paso 4	Active la función y siga las instrucciones de la pantalla.
Paso 5	Cuando la función finalice, retire la bandeja honda.
<p>i Cuando esta función está activa, la luz está apagada.</p>	

11.8 Instrucciones de uso: Vaciado del depósito

Utilice esta función después de cocinar con la función de cocción con vapor para eliminar el agua residual del compartimento de agua.

Antes de empezar:	
Apague el horno y espere a que esté frío.	Retire todos los accesorios.

Paso 1	Coloque la bandeja honda en la primera posición.
Paso 2	Seleccione: Menú / Limpieza / Vaciado del depósito. Duración: 6 minutos
Paso 3	Active la función y siga las instrucciones de la pantalla.
Paso 4	Cuando la función finalice, retire la bandeja honda.
<p> Cuando esta función está activa, la luz está apagada.</p>	

11.9 Cómo quitar e instalar: Puerta

Es posible retirar la puerta del horno y los paneles de cristal interiores para limpiarlos. El número de paneles de cristal es diferente según los modelos.

	ADVERTENCIA! La puerta es pesada.
----------------------------------------------------------------------------------	---------------------------------------------

	PRECAUCIÓN! Maneje con cuidado el cristal, especialmente alrededor de los bordes del panel frontal. El cristal puede romperse.
----------------------------------------------------------------------------------	------------------------------------------------------------------------------------------------------------------------------------------

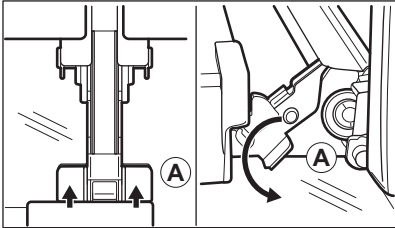
Paso 1	Abra la puerta por completo.	
Paso 2	Levante y presione al máximo las palancas de bloqueo (A) de ambas bisagras de la puerta.	
Paso 3	Cierre la puerta del horno hasta la primera posición de apertura (aproximadamente a un ángulo de 70°). Sostenga la puerta con una mano a cada lado y tire de ella hacia arriba y hacia afuera. Ponga la puerta con el lado exterior hacia abajo sobre un paño suave en una superficie nivelada.	

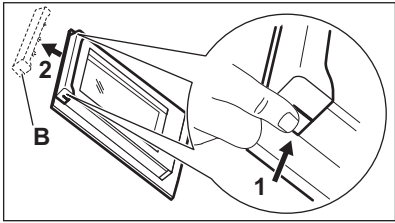
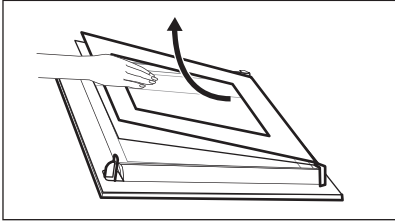
<p>Paso 4</p>	<p>Sujete el marco de la puerta (B) por el borde superior de la puerta por ambos lados y empuje hacia dentro para soltar el cierre.</p>	
<p>Paso 5</p>	<p>Tire del borde del acabado de la puerta hacia delante para desengancharla.</p>	
<p>Paso 6</p>	<p>Sujete uno tras otro los paneles de cristal de la puerta por su borde superior y extráigalos de la guía.</p>	
<p>Paso 7</p>	<p>Limpie el panel de cristal con agua y jabón. Seque el panel de cristal con cuidado. No limpie los paneles de cristal en el lavavajillas.</p>	
<p>Paso 8</p>	<p>Tras la limpieza, lleve a cabo los pasos anteriores en orden inverso.</p>	
<p>Paso 9</p>	<p>Introduzca primero el panel más pequeño y luego el de mayor tamaño y la puerta.</p>	

11.10 Cómo cambiar: Bombilla



ADVERTENCIA!

Riesgo de descarga eléctrica.
La lámpara puede estar caliente.

Antes de reemplazar la bombilla:

Paso 1	Paso 2	Paso 3
<p>Apague el horno. Espere hasta que el horno esté frío.</p>	<p>Desconecte el horno de la red.</p>	<p>Coloque un paño en el fondo de la cavidad.</p>

SOLUCIÓN DE PROBLEMAS

Bombilla superior

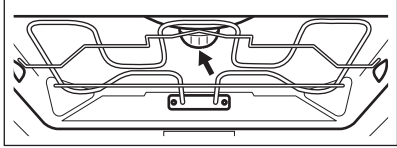
Paso 1	Gire la tapa de cristal para extraerla.	
Paso 2	Retira el anillo metálico y limpia la tapa de vidrio.	
Paso 3	Cambie la bombilla por otra apropiada termorresistente hasta 300 °C.	
Paso 4	Coloque el anillo metálico en la cubierta de cristal e instálela.	

Luz lateral

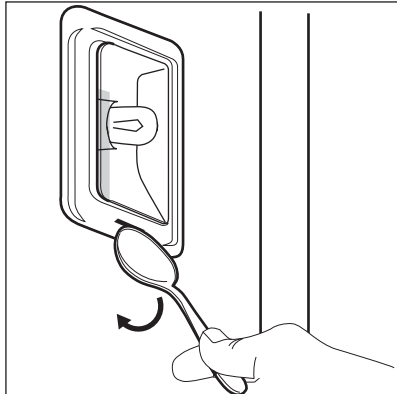
Paso 1	Retira el carril de apoyo izquierdo para acceder a la bombilla.	
Paso 2	Utiliza un objeto estrecho y romo (p. ej., una cucharadita) para retirar la tapa de vidrio.	
Paso 3	Limpie la tapa de cristal.	
Paso 4	Cambie la bombilla por otra apropiada termorresistente hasta 300 °C.	
Paso 5	Instale la tapa de cristal.	
Paso 6	Instala los carriles izquierdos de apoyo.	



12. SOLUCIÓN DE PROBLEMAS





ADVERTENCIA!

Consulte los capítulos sobre seguridad.

12.1 Qué hacer si...

 El aparato no se enciende o no se calienta	
 Posible causa	 Solución
El aparato no está conectado a ningún suministro eléctrico o está mal conectado.	Compruebe si el aparato se ha conectado correctamente a la red eléctrica.
El reloj no está ajustado.	Ajuste el reloj; para obtener más información, consulte Funciones de reloj capítulo, Cómo ajustar: Funciones de reloj.
La puerta no está bien cerrada.	Cierre la puerta del aparato completamente.
Ha saltado el fusible.	Compruebe si el fusible es la causa del problema. Si el problema persiste, póngase en contacto con un electricista cualificado.
El aparato Bloqueo de seguridad está encendido.	Consulte el capítulo "Menú", submenú: Opciones.



 Componentes	
 Descripción	 Solución
La bombilla se ha fundido.	Sustituya la bombilla, para más detalles consulte el capítulo "Mantenimiento y limpieza", Cómo cambiar: Bombilla.

El corte de corriente siempre detiene la limpieza. Repita la limpieza si se interrumpe por un corte de corriente.

12.2 Cómo administrar: Códigos de error

Cuando se produce el error de software, la pantalla muestra un mensaje de error. En esta sección, encontrará la lista de los problemas que puede manejar por su cuenta.

EFICACIA ENERGÉTICA

 Código y descripción	 Solución
C2: el Sonda térmica se encuentra en la cavidad del aparato durante Limpieza pirolítica.	Saque el Sonda térmica.
C3: la puerta no está completamente cerrada durante Limpieza pirolítica.	Cierre la puerta.
F111: Sonda térmica no está introducido correctamente en la toma.	Enchufe a fondo Sonda térmica en la toma.
F240, F439: los campos táctiles de la pantalla no funcionan correctamente.	Limpie la superficie de la pantalla. Asegúrese de que no haya suciedad en los campos táctiles.
F908: el sistema del aparato no puede conectarse con el panel de control.	Encienda y apague el aparato.

12.3 Datos de servicio

Si no logra subsanar el problema, póngase en contacto con su distribuidor o un centro de servicio técnico autorizado.

Los datos que necesita para el Centro de servicio técnico se encuentran en la placa de características. La placa de características se encuentra en el marco delantero del interior del aparato. No retire la placa de características de la cavidad del aparato.

Se recomienda escribir los datos aquí:	
Modelo (MOD):
Número de producto (PNC)
Número de serie (S.N.)

13. EFICACIA ENERGÉTICA

13.1 Información del producto y hoja de información del producto

Nombre del proveedor	AEG
Identificación del modelo	BSE77280M 944188685 BSE77228BM 944188655 BSK772280M 944188643 BSS772280B 944188644

Índice de eficiencia energética	61.2	
Clase de eficiencia energética	A++	
Consumo de energía con una carga estándar, modo convencional	1.09 kWh/ciclo	
Consumo de energía con una carga estándar, modo de ventilador forzado	0.52 kWh/ciclo	
Número de cavidades	1	
Fuente de energía	Electricidad	
Volumen	71 l	
Tipo de horno	Horno empotrable	
Masa	BSE772280M	36.0 kg
	BSE77228BM	36.0 kg
	BSK772280M	36.0 kg
	BSS772280B	36.0 kg

IEC/EN 60350-1 - Aparatos electrodomésticos de cocción - Parte 1: Gamas, hornos, hornos de vapor y grills - Métodos de medida del rendimiento.

13.2 Ahorro energético



El aparato tiene características que le ayudan a ahorrar energía durante la cocina de cada día.

Asegúrese de que la puerta del aparato esté cerrada cuando esté en funcionamiento. No abra la puerta del aparato muchas veces durante la cocción. Mantenga limpia la junta de la puerta y asegúrese de que está bien fijada en su posición.

Utilice utensilios de cocina de metal para mejorar el ahorro energético.

No precaliente el aparato antes de cocinar en la medida de lo posible.

Reduzca al máximo el tiempo entre horneados cuando prepare varios platos de una vez.

Cocción con ventilador

En la medida de lo posible, utilice las funciones de cocción con ventilador para ahorrar energía.

Calor residual

En algunas funciones del aparato, si está activado un programa con Duración y el tiempo de cocción es superior a 30 min, las resistencias se desactivan antes automáticamente.

La bombilla y el ventilador siguen funcionando. Al apagar el aparato la pantalla mostrará el calor residual. El calor puede emplearse para mantener caliente los alimentos.

ESTRUCTURA DEL MENÚ

Para una duración de la cocción superior a 30 minutos, reduzca la temperatura del aparato un mínimo de 3 a 10 minutos antes de llegar al final de la cocción. El calor residual dentro del aparato hará que la comida se siga cocinando.

Utilice el calor residual para calentar otros platos.

Mantener calientes los alimentos

Si desea utilizar el calor residual para mantener calientes los alimentos, seleccione el ajuste de temperatura más bajo posible. El indicador de calor residual o la temperatura aparecen en la pantalla.

Cocción con la bombilla apagada

Apague la luz mientras cocina. Enciéndala únicamente cuando la necesite.

Horneado húmedo + ventilador

Función diseñada para ahorrar energía durante la cocción.

Cuando utilice esta función, la lámpara se apagará automáticamente después de 30 segundos. Puede volver a encender la luz, pero de este modo reducirá el ahorro energético esperado.

14. ESTRUCTURA DEL MENÚ

14.1 Menú

Elemento del menú		Aplicación
Cocción asistida		Muestra los programas automáticos.
Limpieza		Muestra los programas de limpieza.
Favoritos		Muestra los ajustes favoritos.
Opciones		Para ajustar la configuración del aparato.
Ajustes	Configuración	Para ajustar la configuración del aparato.
	Asistencia	Muestra la configuración y la versión del software.

14.2 Submenú de: Limpieza

Submenú	Aplicación
Vaciado del depósito	Procedimiento para retirar el agua residual del compartimento de agua después de utilizar las funciones de vapor.
Limpieza pirolítica, rápida	Duración: 1 h.
Limpieza pirolítica, normal	Duración: 1 h 30 min.
Limpieza pirolítica, intensa	Duración: 3 h.

Submenú	Aplicación
Descalcificación	Procedimiento para limpiar el circuito de generación de restos de cal.
Aclarado	Procedimiento para aclarar y limpiar el circuito de generación de vapor después de un uso frecuente de las funciones de vapor.

14.3 Submenú de: Opciones

Submenú	Aplicación
Luz	Enciende y apaga la luz.
Bloqueo de seguridad	Evita la activación accidental del aparato. Con esta opción activada, en la pantalla aparece Bloqueo de seguridad cuando se enciende el aparato. Para activar el uso del aparato, seleccione las letras del código en orden alfabético. Cuando la opción está activada y el aparato está apagado, la puerta está bloqueada. Acceda al temporizador, el funcionamiento remoto y la lámpara está disponible con la opción activada.
Calentamiento rápido	Reduce el tiempo de calentamiento. Solo está disponible para algunas de las funciones del aparato.
Indicación tiempo	Enciende y apaga el reloj.
Opción de hora digital	Cambia el formato de la indicación de tiempo mostrada.

14.4 Submenú de: Configuración

Submenú	Descripción
Idioma	Establece el idioma del aparato.
Brillo de la pantalla	Ajusta el brillo de la pantalla.
Tono de teclas	Activa y desactiva el tono de los campos táctiles. No es posible silenciar el tono de: ①.

Submenú	Descripción
Volumen del timbre	Ajusta el volumen de los tonos y señales de las teclas.
Dureza del agua	Ajusta la dureza del agua.
Hora	Ajusta la hora y la fecha actuales.

14.5 Submenú para: Asistencia

Submenú	Descripción
Modo demostración	Código de activación/desactivación: 2468
Versión del software	Información sobre versión de software.
Restaurar todos los ajustes	Restaura los ajustes de fábrica.



15. ¡ES FÁCIL!



Antes del primer uso, debe ajustar:

Idioma	Brillo de la pantalla	Tono de teclas	Volumen del timbre	Dureza del agua	Hora
--------	-----------------------	----------------	--------------------	-----------------	------

Empezar a utilizar el aparato



Inicio rápido	Encienda el aparato y comience a cocinar con la temperatura y el tiempo por defecto de la función.	Paso 1	Paso 2	Paso 3
		Mantenga pulsado: ①.	 ... - seleccione la función preferida.	Pulse: START .
Apagado rápido	Apague el aparato en cualquier pantalla o mensaje en cualquier momento.	①: mantenga pulsado hasta que el aparato se apague.		

Empezar a cocinar				
Paso 1	Paso 2	Paso 3	Paso 4	Paso 5
 : pulse para encender el aparato.	 ... - seleccione la función de cocción.	 - ajuste la temperatura .	OK - pulse para confirmar.	START - pulse para iniciar la cocción.

Aprenda a cocinar rápidamente				
Use los programas automáticos para preparar rápidamente un plato con los ajustes por defecto:				
Cocción asistida	Paso 1	Paso 2	Paso 3	Paso 4
	Pulse:  .	Pulse:  .	Pulse:  Cocción asistida.	Elija el plato.

Use las funciones rápidas para ajustar el tiempo de cocción	
Asistente de acabado 10 % Use el Asistente de acabado 10 % para añadir tiempo extra cuando quede un 10 % del tiempo de cocción.	Para prolongar el tiempo de cocción, pulse +1 min.

16. ASPECTOS MEDIOAMBIENTALES

Recicle los materiales con el símbolo . Coloque el material de embalaje en los contenedores adecuados para su reciclaje. Ayude a proteger el medio ambiente y la salud pública, así como a reciclar residuos de aparatos eléctricos y electrónicos. No deseche los aparatos marcados con el símbolo  junto con los residuos domésticos. Lleve el producto a su centro de reciclaje local o póngase en contacto con su oficina municipal.

FÖR PERFEKTA RESULTAT

Tack för att du valt denna AEG-produkt. Den har utvecklats för att du ska kunna använda den i många år, med innovativa funktioner som gör livet enklare – och som inte finns på alla enklare produkter. Ägna några minuter åt denna beskrivning för att få största möjliga utbyte av produkten.

Besök vår webbplats för att:



få tips om användning, broschyrer, felsökning, service- och reparationsinformation:
www.aeg.com/support



registrera din produkt för bättre service:
www.registreaeg.com



köpa tillbehör, förbrukningsvaror och originalreservdelar till din produkt:
www.aeg.com/shop

KUNDTJÄNST OCH SERVICE

Använd alltid originalreservdelar.

Ha följande uppgifter till hands när du kontaktar vår auktoriserade serviceverkstad: Modell, artikelnummer, serienummer.

Informationen står på märkplåten.

 Varning/Försiktighet – Säkerhetsinformation

 Allmän information och tips

 Miljöinformation

Med reservation för ändringar.

INNEHÅLL

1. SÄKERHETSINFORMATION.....	297	3.2 Tillbehör.....	304
1.1 Säkerhet för barn och personer med funktionsnedsättning.....	298	4. KONTROLLPANELEN.....	304
1.2 Allmän säkerhet.....	298	4.1 Översikt av kontrollpanelen.....	304
2. SÄKERHETSINSTRUKTIONER.....	299	4.2 Display.....	305
2.1 Installation.....	299	5. FÖRE FÖRSTA ANVÄNDNING.....	306
2.2 Elanslutning.....	300	5.1 Första rengöring	306
2.3 Använd.....	301	5.2 Första anslutning.....	306
2.4 Underhåll och rengöring.....	302	5.3 Initial föruppvärmning.....	306
2.5 Pyrolytisk rengöring.....	302	5.4	
2.6 Matlagning med ånga.....	302	Så här ställer du in: Vattenhårdhet....	307
2.7 Invändig belysning.....	303	6. DAGLIG ANVÄNDNING.....	308
2.8 Service.....	303	6.1	
2.9 Avyttring.....	303	Så här ställer du in: Tillagningsfunktion er.....	308
3. PRODUKTBEKRIVNING.....	303	6.2 Så här ställer du in: Ånga tillagningsfunktioner.....	308
3.1 Allmän översikt.....	303		

6.3 Hur man ställer in: Assisterad matlagning.....	309	11.2 Hur man tar bort: Ugnstegar ...	322
6.4 Värmefunktioner.....	310	11.3 Så här använder du: Pyrolytisk rengöring.....	322
6.5 Anvisningar om: Bakning med fukt.....	312	11.4 Påminnelse om rengöring.....	323
7. KLOCKFUNKTIONER.....	312	11.5 Så här använder du: Avkalkning.....	323
7.1 Beskrivning av klockfunktioner....	312	11.6 Avkalkningspåminnelse.....	324
7.2 Så här ställer du in: Klockfunktioner..	313	11.7 Så här använder du: Sköljning.....	325
8. ANVÄNDNING AV TILLBEHÖR.....	314	11.8 Användning: Tömning av tanken.....	325
8.1 Sätta in tillbehör.....	314	11.9 Hur man tar bort och installerar: Lucka n.....	326
8.2 Matlagningstermometer.....	315	11.10 Byte av: Lampa.....	327
8.3 Så här använder du: Matlagningstermometer.....	315	12. FELSÖKNING.....	328
9. TILLVALSFUNKTIONER.....	317	12.1 Vad gör jag om	328
9.1 Så här sparar du: Favoriter.....	317	12.2 Hur man hanterar: Felkoder.....	329
9.2 Funktionsläs.....	317	12.3 Servicedata.....	329
9.3 Automatisk avstängning.....	317	13. ENERGIEFFEKTIVITET.....	330
9.4 Kylfläkt.....	318	13.1 Produktinformation och produktinformationsblad.....	330
10. RÅD OCH TIPS.....	318	13.2 Energibesparing.....	331
10.1 Tillagningsrekommendationer....	318	14. MENYSTRUKTUR.....	331
10.2 Bakning med fukt.....	318	14.1 Meny.....	331
10.3 Bakning med fukt - rekommenderade tillbehör.....	319	14.2 Undermeny för: Rengöring.....	332
10.4 Tillagningstabeller för testinstitut.....	319	14.3 Undermeny för: Tillval.....	332
11. SKÖTSEL OCH RENGÖRING.....	321	14.4 Undermeny för: Inställningar.....	333
11.1 Rengöring.....	321	14.5 Undermeny för: Service.....	333
		15. ENKELT!.....	333
		16. MILJÖSKYDD.....	335

1. ⚠ SÄKERHETSINFORMATION

Läs noga de bifogade instruktionerna före installation och användning av produkten. Tillverkaren är inte ansvarig för eventuella personskador eller andra skador som uppkommit som ett resultat av felaktig installation eller användning. Förvara alltid bruksanvisningen på en säker och tillgänglig plats för framtida bruk.

1.1 Säkerhet för barn och personer med funktionsnedsättning

- Denna produkt kan användas av barn från 8 års ålder och uppåt, och av personer med nedsatt fysisk, sensorisk eller mental förmåga, samt personer med bristande erfarenhet och kunskap om de övervakas eller instrueras om hur produkten används på ett säkert sätt och förstår de risker som är förknippade med användningen. Barn under 8 år eller personer med mycket omfattande och komplexa funktionsnedsättningar ska inte vistas i närheten av produkten utan ständig uppsikt.
- Barn ska hållas under uppsikt så att de inte leker med produkten.
- Håll allt förpackningsmaterial utom räckhåll för barn och kassera det på lämpligt sätt.
- **WARNING!** Ugnen och åtkomliga delar blir mycket varma under användning. Håll barn och husdjur borta från produkten när den används och när den svalnar.
- Om maskinen har ett barnlås ska den aktiveras.
- Barn får inte utföra rengöring och underhåll av produkten utan uppsikt.

1.2 Allmän säkerhet

- Denna produkt är endast avsedd för matlagning.
- Denna produkt är avsedd för enskilt hushållsbruk inomhus.
- Produkten kan användas i kontor, hotellrum, gårdsgästhus och liknande boenden där sådan användning inte innebär att genomsnittlig hushållsförbrukning överskrids.
- Installation av denna produkt och byte av kabeln får endast utföras av behörig person.
- Använd inte produkten innan den har installerats i inbyggnadsstrukturen.
- Bryt strömförsörjningen till apparaten före utförande av underhåll.

- Om nätsladden är skadad måste den bytas av tillverkaren, tillverkarens auktoriserade servicecenter eller personer med motsvarande utbildning, för att undvika fara.
- **WARNING!** Kontrollera att produkten är avstängd innan du byter lampa för att undvika risk för elektriska stötar.
- **WARNING!** Ugnen och åtkomliga delar blir mycket varma under användning. Var försiktig så att du inte vidrör värmeelementen eller ugnsutrymmet.
- Använd alltid ugnsvantar vid iläggning eller urtagning av tillbehör eller ugnsformar.
- Använd endast matlagningstermometern som rekommenderas för den här produkten.
- För att ta bort en ugnsstege drar du först ut stegen framtill och sedan den bakre delen från sidoväggen. Sätt tillbaka ugnsstegar i omvänd ordning.
- Använd inte ångrengöringsmedel för att rengöra produkten.
- Använd inte skarpa rengöringsmedel med slipeffekt eller vassa metallskrapor för att rengöra luckans glas för att undvika repor, vilka i sin tur kan leda till att glaset spricker.
- Ta bort alla tillbehör från ugnen och avlägsna större avlagringar/spill från utrymmet före pyrolytisk rengöring.

2. SÄKERHETSINSTRUKTIONER

2.1 Installation

**WARNING!**

Endast en behörig person får installera den här produkten.

- Avlägsna allt förpackningsmaterial.
- Installera eller använd inte en skadad produkt.
- Följ installationsinstruktionerna som följer med produkten.
- Var alltid försiktig när produkten rör sig eftersom den är tung. Använd alltid skyddshandskar och täckta skor.
- Dra aldrig produkten i handtaget.
- Installera produkten på en säker och lämplig plats som uppfyller installationskraven.
- Minsta avstånd till andra produkter ska beaktas.
- Kontrollera, före installation av ugnen, att ugnsluckan kan öppnas enkelt utan motstånd.
- Produkten är utrustad med ett elektriskt kylsystem. Den måste användas med den elektriska strömförsörjningen.
- En inbyggd enhet måste uppfylla stabilitetskraven enligt DIN 68930.

SÄKERHETSINSTRUKTIONER

Skåpets minimihöjd (minsta höjd för skåpet under bänk)	578 (600) mm
Skåpets bredd	560 mm
Skåpets djup	550 (550) mm
Höjd på produktens främre del	594 mm
Höjd på produktens bakre del	576 mm
Bredd på produktens främre del	595 mm
Bredd på produktens bakre del	559 mm
Produktens djup	567 mm
Inbyggnadsdjup för produkten	546 mm
Djup med öppen lucka	1027 mm
Minsta storlek på ventilationsöppningen. Öppning placerad nedtill på vänstra sidan	560x20 mm
Nätsladdens längd. Kabeln är placerad i det nedre högra hörnet på baksidan	1500 mm
Monteringssskruvar	4x25 mm

2.2 Elanslutning



WARNING!

Risk för brand och elektriska stötar.

- Alla elektriska anslutningar ska göras av en behörig elektriker.
- Produkten måste jordas.
- Se till att de parametrarna på märkskylten överensstämmer med elnätets elektricitet.
- Använd alltid ett korrekt installerat, stötsäkert och jordat eluttag.
- Använd inte grenuttag eller förlängningssladdar.
- Kontrollera så att du inte skadar stickkontakten och nätkabeln. Om produktens nätkabel behöver bytas måste det göras av vårt auktoriserade servicecenter.
- Låt inte nätkablar komma i kontakt med eller komma nära produktens lucka eller nichen nedanför produkten, speciellt inte när den är igång eller om luckan är het.
- Stötskyddet för strömförande och isolerade delar måste fästas på ett sådant sätt att det inte kan tas bort utan verktyg.
- Anslut stickkontakten till eluttaget först vid slutet av installationen. Kontrollera att stickkontakten är åtkomlig efter installationen.

- Anslut inte stickkontakten om vägguttaget sitter löst.
- Dra inte i anslutningsladdan för att koppla bort produkten från eluttaget. Ta alltid tag i stickkontakten.
- Använd endast rätt isoleringsenheter: strömbrytare, säkringar (säkringar av skruvtyp tas ur hållaren), jordfelsbrytare och kontaktorer.
- Den elektriska installationen måste ha en isolationsenhet så att du kan koppla från produkten från nätet vid alla poler. Kontaktöppningen på isolationsenheten måste vara minst 3 mm bred.
- Stäng produktens lucka helt innan du ansluter kontakten till eluttaget.
- Denna produkt levereras med en huvudkontakt och en huvudkabel

2.3 Använd



VARNING!

Risk för skador, brännskador, elstötar eller explosion föreligger.

- Ändra inte produktens specifikationer.
- Kontrollera att ventilationsöppningarna inte är blockerade.
- Låt inte produkten stå utan uppsikt under användning.
- Stäng av produkten efter varje användningstillfälle.
- Var försiktig när du öppnar produktens lucka medan produkten är påslagen. Varm luft kan strömma ut.
- Använd inte produkten med våta händer eller när den har kontakt med vatten.
- Tryck inte på den öppna luckan.
- Använd inte produkten som arbets- eller avlastningsyta.
- Öppna luckan försiktigt. Användning av ingredienser med alkohol kan orsaka blandning av alkohol och luft.
- Låt inte gnistor eller öppna lågor komma i kontakt med produkten när du öppnar luckan.
- Placera inte brandfarliga produkter eller föremål som är våta med brandfarliga produkter i, i närheten av eller på produkten.



VARNING!

Risk för skador på produkten föreligger.

- För att förhindra skador eller missfärgning på emaljen:
 - placera inte eldfasta formar eller andra föremål direkt på ugsnbotten.
 - lägg inte aluminiumfolie direkt på ugsnbotten.
 - håll inte vatten direkt i den heta produkten.
 - Låt inte fuktiga maträtter eller matvaror stå kvar i produkten när tillagningen är klar.
 - var försiktig när du tar bort eller installerar tillbehören.
- Missfärgning av emaljen eller den rostfria ytan påverkar inte produktens funktion.
- Använd en djup form för mjuka kakor. Fruktjuice kan orsaka fläckar som inte går att ta bort.
- Laga alltid mat med luckan stängd.
- Om produkten installeras bakom en beklädnadspanel, till exempel i ett skåp, se till att skåpsdörren eller panelen aldrig är stängd när produkten används. Värme och fukt kan byggas upp bakom en stängd lucka och orsaka skador på produkten, skåpsmöblerna eller golvet. Stäng inte luckan förrän produkten har svalnat helt efter användning.

2.4 Underhåll och rengöring



VARNING!

Det finns risk för personskador, brand eller skador på produkten.

- Stäng av produkten och koppla bort den från eluttaget före underhåll.
- Se till att produkten har svalnat. Det finns även risk för att glaspanelerna kan spricka.
- Byt omedelbart ut luckans glaspaneler om de är skadade. Kontakta auktoriserat servicecenter.
- Var försiktig när du tar bort luckan. Luckan är tung!
- Rengör produkten regelbundet för att förhindra att ytmaterialiet försämrats.
- Rengör produkten med en fuktig, mjuk trasa. Använd bara milda rengöringsmedel. Använd inte produkter med slipeffekt, skursvampar, lösningsmedel eller metallföremål.
- Om du använder en ugnssprej ska du följa säkerhetsanvisningarna på förpackningen.

2.5 Pyrolytisk rengöring



VARNING!

Risk för skador / brand / kemiska utsläpp (rök) i Pyrolysläget.

- Innan den katalytiska rengöringen och föruppvärmningen startas ska följande tas bort från ugnen:
 - Eventuella matrester, olje- eller fettspill/avlagringar.
 - alla löstagbara föremål (inklusive hyllor, ugnsstegar osv., som medföljer produkten), särskilt kastruller, pannor, brickor, redskap osv. med non-stick-beläggning.
- Läs noga igenom alla instruktioner för pyrolytisk rengöring.
- Håll barn borta från produkten när pyrolytisk rengöring är igång. Produkten blir mycket varm och varm luft släpps ut från de främre ventilationsöppningarna.
- Pyrolytisk rengöring är en högtemperaturfunktion som kan avge ångor från matrester och byggnadsmaterial, och därför bör användaren:
 - Ombesörja god ventilation under och efter varje pyrolytisk rengöring.
 - ge god ventilation under och efter den första förvärmningen.
- Spill eller applicera inte vatten på ugnsluckan under och efter pyrolytisk rengöring för att undvika att skada glasrutorna.
- Ångor som släpps ut från pyrolytiska/matlagningsrester är inte skadliga för människor, inte heller för barn och eller personer med olika sjukdomstillstånd.
- Håll små husdjur borta från produkten under och efter pyrolytisk rengöring och den initiala föruppvärmningen. Små sällskapsdjur (särskilt fåglar och reptiler) kan vara mycket känsliga för temperaturförändringar och avgivna ångor.
- Teflonbeläggningar på kastruller, stekpannor, brickor, köksredskap osv. kan skadas av den höga temperaturen vid användning av pyrolytisk rengöring i alla pyrolytiska ugnar och kan också vara en källa till skadliga ångor i låg grad.

2.6 Matlagning med ånga



VARNING!

Det finns risk för brännskador och skador på produkten.

- Ånga som släpps ut kan orsaka brännskador:
 - Var försiktig när du öppnar produktens lucka medan produkten är igång. Ånga kan släppas ut.
 - Öppna ugnsluckan försiktigt efter ångkokning.

2.7 Invändig belysning



VARNING!

Risk för elektrisk stöt!

- När det gäller lampan/lamporna i denna produkt och reservlampor som säljs separat: Dessa lampor är avsedda att tåla extrema fysiska förhållanden i hushållsapparater, såsom temperatur, vibration, fuktighet eller är avsedda att signalera information om produktens driftstatus. De är inte avsedda att användas i andra produkter eller som rumsbelysning i hemmet.
- Denna produkt innehåller en ljuskälla med energieffektivitetsklass G.
- Använd bara lampor med samma specifikationer.

2.8 Service

- Kontakta ett auktoriserat servicecenter för reparation av produkten.
- Använd endast originalreservdelar.

2.9 Avyttring



VARNING!

Risk för kvävning eller skador.

- Kontakta kommunen för information om hur produkten ska kasseras.
- Koppla loss produkten från eluttaget.
- Klipp av elkabeln nära produkten och kassera den.
- Ta bort luckspärren för att förhindra att barn eller husdjur blir instängda i maskinen.

3. PRODUKTBESKRIVNING

3.1 Allmän översikt

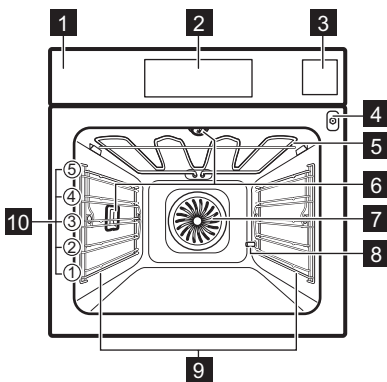

- 1** Kontrollpanel
- 2** Display
- 3** Vattenlåda
- 4** Uttag för matlagningstermometern
- 5** Värmeelement
- 6** Lampa
- 7** Fläkt
- 8** Avkalkning av rötutlopp
- 9** Ugnstegar, borttagbara
- 10** Hyllplaceringar

KONTROLLPANELEN

3.2 Tillbehör

Galler

För kokkärl, kakformar, stekar.

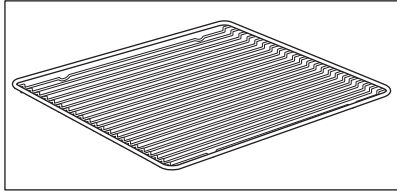

Bakplåt

För kakor och småkakor.

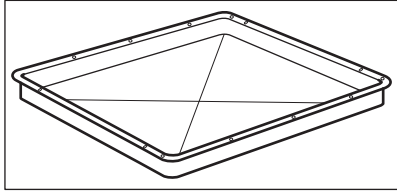

Grill- / stekpanna

För bakning och stekning eller som fettuppsamlingsfat.

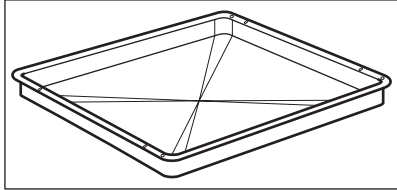

Matlagningstermometer

För att mäta temperaturen inuti maten.

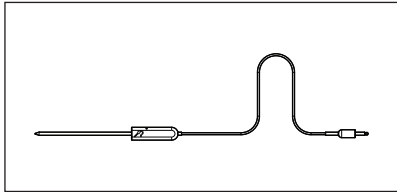

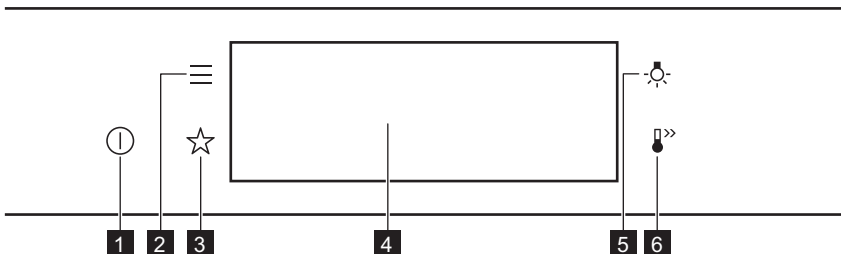

4. KONTROLLPANELEN

4.1 Översikt av kontrollpanelen





1	På / Av	Tryck och håll inne för att slå på och stänga av ugnen.
2	Meny	Visar ugnsfunktionerna.
3	Favoriter	Förteckning av favoritinställningar.
4	Display	Visar produktens aktuella inställningar.
5	Lampans strömbrytare	Tända och släcka lampan.
6	Snabbuppvärmning	Aktivera och inaktivera funktionen: Snabbuppvärmning.

 Tryck	 Flytta	 Tryck och håll inne
Vidrör ytan med fingertoppen.	Dra fingret över ytan.	Tryck på ytan i tre sekunder.

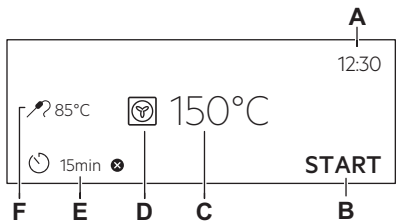



4.2 Display

	<p>Display med inställda funktioner.</p> <p>A. Klockslag B. START/STOPP C. Temperatur D. Tillagningsfunktioner E. Timer F. Matlagningstermometer (endast vissa modeller)</p>
------------------------------------------------------------------------------------	-----------------------------------------------------------------------------------------------------------------------------------------------------------------------------------------------------------------------------------------------

Indikeringar på displayen

Grundindikeringar - för att navigera på displayen.			
OK För att bekräfta val/inställning.	 Gå tillbaka en nivå i menyn så här.	 Ängra den senaste åtgärden så här.	 För att slå på och stänga av funktionerna.
Ljudalarm funktionsindikatorer - när den inställda tillagningstiden har gått avges en ljudsignal.			

FÖRE FÖRSTA ANVÄNDNING

 Funktionen är på.	 Funktionen är på. Matlagningen avslutas automa- tiskt.	 Ljudlarm avstängt.
Timer-indikatorer		
 För att ställa in funktionen: Fördröjd start.	 Avbryta inställningen.	



5. FÖRE FÖRSTA ANVÄNDNING



WARNING!

Se Säkerhetsavsnitten.

5.1 Första rengöring

		
Steg 1	Steg 2	Steg 3
Ta ut alla tillbehör och borttagbara ugnstegar ur ugnen.	Rengör produkten och dess tillbehör med en mikrofiberrduk, varmt vatten och ett mildt rengöringsmedel.	Sätt in tillbehören och de lös- tagbara ugnstegarna i ugnen.



5.2 Första anslutning

Displayen visar ett välkomstmeddelande när maskinen har anslutits första gången. Du måste ställa in: Språk, Ljusstyrka i display, Knappljud, Ljudvolym knappar, Vattenhårdhet, Klockslag.

5.3 Initial föruppvärmning





Sätt den tomma ugnen på förvärmning innan du använder den första gången.

Steg 1	Ta ut alla tillbehör och flyttbara ugnstegar ur ugnen.
Steg 2	Ställ in maxtemperatur för funktionen:  Låt ugnen stå på i en timma.





Steg 3	Ställ in maxtemperatur för funktionen:  Låt ugnen stå på i 15 minuter.
 Ugnen kan avge lukt och rök under föruppvärmning. Se till att rummet är ventilerat.	

5.4 Så här ställer du in: Vattenhårdhet

När du ansluter produkten till elnätet måste du ställa in vattnets hårdhetsnivå. Använd testpapperet eller kontakta din vattenleverantör för att kontrollera vattenhårdheten.

			
Steg 1	Steg 2	Steg 3	Steg 4
Lägg testpapperet i vatten i ca 1 sekund. Håll inte testpapperet under rinnande vatten.	Skaka testpapperet för att avlägsna vattenöverskottet.	Vänta 1 minut och kontrollera sedan vattnets hårdhetsgrad enligt tabellen nedan.	Ställ in nivån för vattenhårdheten: Meny / Inställningar / Inställningar / Vattenhårdhet.
 Färgerna på testpapperet fortsätter att ändras. Vänta inte längre än 1 minut med att avläsa vattnets hårdhetsgrad.			
Du kan ändra nivån för vattnets hårdhetsgrad i menyn: Inställningar / Inställningar / Vattenhårdhet.			

I tabellen anges vattnets hårdhetsgrad (Dh) med motsvarande kalkavlagringar och vattenklassificering. Justera vattnets hårdhetsnivå enligt tabellen.

Vattenhårdhet		Testpapper	Kalkavlagringar (mmol/l)	Kalkavlagringar (mg/l)	Vattenklassificering
Nivå	dH				
1	0 - 7		0 - 1.3	0 - 50	mjukt
2	8 - 14		1.4 - 2.5	51 - 100	medelhårt
3	15 - 21		2.6 - 3.8	101 - 150	hårt
4	≥ 22		≥ 3,9	≥ 151	mycket hårt

När nivån på vattenhårdheten är 4, fyll vattenlådan med flaskvatten utan kolsyra.

6. DAGLIG ANVÄNDNING



VARNING!

Se Säkerhetsavsnitten.

6.1 Så här ställer du in: Tillagningsfunktioner

Steg 1	Slå på ugnen. Standardtillagningsfunktionen visas på displayen.
Steg 2	Tryck på symbolen för tillagningsfunktionen för att gå till undermenyn.
Steg 3	Välj tillagningsfunktion och tryck på: OK . Displayen visar: temperatur.
Steg 4	Ställ in: temperatur. Tryck på: OK .
Steg 5	Tryck på: START . Matlagningstermometer – du kan koppla in matlagningstermometern när som helst före eller under tillagningen.
STOP – tryck för att stänga av tillagningsfunktionen.	
Steg 6	Stäng av ugnen.

6.2 Så här ställer du in: Ånga tillagningsfunktioner

Steg 1	Slå på ugnen. Välj symbolen för tillagningsfunktionen och tryck på den för att komma in i undermenyn.
Steg 2	Tryck  . Välj ånguppvärmningsfunktionen.
Steg 3	Tryck på: OK . Temperaturinställningarna visas på displayen.
Steg 4	Ställ in temperaturen.
Steg 5	Tryck på: OK .
Steg 6	Tryck på locket på vattenlådan för att öppna den.

Steg 7	Fyll vattenlådan med kallt vatten till maxnivån (ca 950 ml) tills ljudsignalen hörs eller displayen visar ett meddelande. Fyll inte vattenlådan över max-nivån. Det finns risk för vattenläckage, översvämning eller skada på inredningen.
	 VARNING! Använd endast kallt kranvatten. Använd inte filtrerat (demineraliserat) eller destillerat vatten. Använd inga andra vätskor. Håll inte lättantändlig vätska eller alkohol i vattenlådan.
Steg 8	Tryck in vattenlådan i sitt ursprungliga läge.
Steg 9	Tryck på: START . Ångan kommer efter cirka 2 minuter. När ugnen når den inställda temperaturen avges en ljudsignal.
Steg 10	När vattenlådan blir tom på vatten hörs en ljudsignal. Fyll på vattenlådan.
Steg 11	Stäng av ugnen.
Steg 12	Töm vattenlådan när tillagningen med ånga är klar. Se kapitlet "Underhåll och rengöring", Tömning av tanken.
Steg 13	Restvatten kan kondensera inuti ugnen. När tillagningen är klar, öppna ugnsluckan försiktigt. När ugnen har svalnat kan den rengöras med en mjuk trasa.

6.3 Hur man ställer in: Assisterad matlagning



Varje maträtt i denna undermeny har en föreslagen funktion och temperatur. Du kan ändra tiden och temperaturen.

För vissa maträtter kan tillagningen också styras med:

- Automatisk vikt
- Matlagningstermometer

Till vilken grad maträtten ska tillagas:

- Rare eller Mindre
- Medium
- Well Done eller Mer









Steg 1	Slå på ugnen.
Steg 2	Tryck på: 
Steg 3	Tryck på:  . Ange: Assisterad matlagning.
Steg 4	Välj maträtt eller mattyp.

Steg 5









Tryck på: START .

6.4 Värmefunktioner

STANDARD



Tillagningsfunktion	Program
 Grill	För grillning av tunnskurna stycken och brödrostning.
 Varmluftsgillning	Varmluftstekning på första ugnsnivån av större köttstycken eller fågelkött med ben. För att bryna och göra gratänger.
 Varmluft	För bakning eller torkning på upp till tre ugnsnivåer samtidigt. Välj en temperatur 20 till 40 °C lägre än för Över-/undervärme.
 Frost mat	För tillagning av snabbmat (som pommes frites, klyftpotatis och vårrullar) med en krispig effekt.
 Över-/undervärme	Bakning och stekning på en ugnsnivå.
 Pizza/Paj	För att tillaga pizza. För att bryna ordentligt och få en knaprig botten.
 Undervärme	För bakning av kakor med knaprig botten och för konservering av livsmedel.
 Jäsning av deg	För snabbare degjäsning. Den håller degen elastisk och förhindrar att ytan torkar.

SPECIAL

Tillagningsfunktion	Program
 <p>Konservering</p>	För att konservera grönsaker (t.ex. pickles).
 <p>Torkning</p>	För torkning av skivad frukt, grönsaker och svamp.
 <p>Tallriksvärmning</p>	För förvärmning av tallrikar för servering.
 <p>Upptining</p>	För att tina mat (grönsaker och frukt). Upptiningstiden beror på mängden och storleken på den frysta maten.
 <p>Gratinering</p>	För rätter som lasagne eller potatisgratäng. För att bryna och göra gratänger.
 <p>Långsam tillagning</p>	Tillagning av möra, saftiga stekar.
 <p>Varmhållning</p>	För varmhållning av maträtter.
 <p>Bakning med fukt</p>	Denna funktion är för att spara energi under tillagningen. När du använder den här funktionen kan temperaturen i ugnen skilja sig från inställd temperatur. Restvärmen används. Värmeeffekten kan minskas. Mer information finns i kapitlet "Daglig användning" och anvisningar om: Bakning med fukt.

KLOCKFUNKTIONER

ÅNGA

Tillagningsfunktion	Program
 Uppvärmning med ånga	Uppvärmning av mat med ånga gör att ytan inte torkar. Värmen fördelas skonsamt och jämnt, vilket bevarar smaken bättre på maten du värmer upp. Funktionen kan användas för att värma mat direkt på tallriken. Du kan värma upp mer än en tallrik samtidigt med hjälp av olika nivåer i ugnen.
 Brödbakning	Med den här funktionen kan du baka bröd och bullar med professionellt resultat vad gäller krispighet, färg och glans.
 Fuktighet, låg	Funktionen är lämplig för kött, fågel, ugnsrätter och grytor. Tack vare kombinationen av ånga och värme får köttet en mör och saftig konsistens och en krispig yta.

6.5 Anvisningar om: Bakning med fukt

Denna funktion användes för att uppfylla kraven för energieffektivitet och ekodesigns /enligt EU 65/2014 och EU 66/2014). Tester enligt:

IEC/EN 60350-1

Ugnsluckan ska vara stängd under tillagningen så att funktionen inte avbryts och ugnen fungerar med högsta möjliga energieffektivitet.

Om du använder den här funktionen släcks lampan automatiskt efter 30 sekunder.

För tillagningsinstruktioner, se kapitlet "Råd och tips" Bakning med fukt. För instruktioner om allmän energibesparing, se kapitlet "Energieffektivitet", energibesparing.

7. KLOCKFUNKTIONER

7.1 Beskrivning av klockfunktioner

Klockfunktion	Program
Tillagningstid	För att ställa in tillagningstiden. Max är 23 tim och 59 min.
Slutalternativ	Ställ in vad som händer när tidtagningen slutar.
Fördröjd start	För att fördröja tillagningens start- och/eller sluttid.
Förlängning av tid	För att förlänga tillagningstiden.
Påminnelse	För att ställa in en nedräkning. Max är 23 t och 59 min. Denna funktion påverkar inte ugnens funktioner i övrigt.

Klockfunktion	Program
Upptimer	Övervakar hur länge funktionen är igång. Upptimer - Du kan slå på och stänga av den.

7.2 Så här ställer du in: Klockfunktioner

Ställa in tiden	
Steg 1	Tryck på: Klockslag.
Steg 2	Ställ in tidtagningen. Tryck på: OK.

Så här ställer du in tillagningstiden	
Steg 1	Välj uppvärmningsfunktionen och ställ in temperaturen.
Steg 2	Tryck på:  .
Steg 3	Ställ in tidtagningen. Tryck på: OK.

Så här väljer du slutalternativ	
Steg 1	Välj uppvärmningsfunktionen och ställ in temperaturen.
Steg 2	Tryck på:  .
Steg 3	Ställ in tillagningstiden.
Steg 4	Tryck på: ● ● ● .
Steg 5	Tryck på: Slutalternativ.
Steg 6	Välj önskat: Slutalternativ.
Steg 7	Tryck på: OK. Upprepa tills displayen visar huvudskärmen.

ANVÄNDNING AV TILLBEHÖR

Så här försröjer du starttiden	
Steg 1	Välj tillagningsfunktion och temperatur.
Steg 2	Tryck på:  .
Steg 3	Ställ in tillagningstiden.
Steg 4	Tryck på: ● ● ● .
Steg 5	Tryck på: Fördröjd start.
Steg 6	Välj värde.
Steg 7	Tryck på: OK. Upprepa tills displayen visar huvudskärmen.

Så här förlänger du tillagningstiden	
När 10 % av tillagningstiden återstår och maten inte verkar vara klar, kan man förlänga tillagningstiden. Du kan också ändra tillagningsfunktionen.	
Tryck på +1min för att förlänga tillagningstiden.	

Så här ändrar du tidtagningsinställningarna	
Steg 1	Tryck på:  .
Steg 2	Ställ in värdet på timern.
Steg 3	Tryck på: OK.
Du kan ändra inställd tid när som helst under tillagningen.	

8. ANVÄNDNING AV TILLBEHÖR



VARNING!

Se Säkerhetsavsnitten.

8.1 Sätta in tillbehör

Liten inbuktning upptill ökar säkerheten. Fördjupningarna är gör också enheterna tipsäkra. Den höga kanten runt hyllan hindrar att kokkärl glider av.

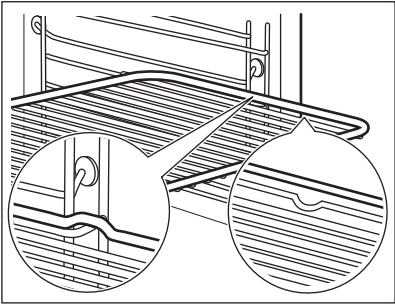
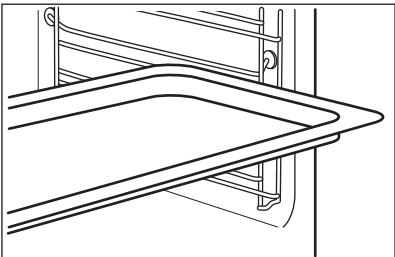
<p>Galler: Skjut in gallret mellan ugnstegens ledskenor.</p>	
<p>Bakplåt / Djup form: Skjut in långpannan mellan ugnstegarnas ledskenor.</p>	

8.2 Matlagningstermometer

Matlagningstermometer- mäter temperaturen inuti maten. Du kan använda den med varje tillagningsfunktion.

Två temperaturer ska ställas in:	
<p style="text-align: center;">°C</p> <p>Ugnstemperatur: minst 120 °C.</p>	<p style="text-align: center;"></p> <p>Tillagningstemperaturen.</p>



För bästa resultat:		
<p>Ingredienserna ska hålla rumstemperatur.</p>	<p>Den är inte lämplig för flytande rätter.</p>	<p>Under tillagning ska den vara inuti maten.</p>

Ugnen beräknar en ungefärlig sluttid. Denna beror på mängden mat, inställd ugnsfunktion och temperatur.

8.3 Så här använder du: Matlagningstermometer

Steg 1	Slå på ugnen.
---------------	---------------

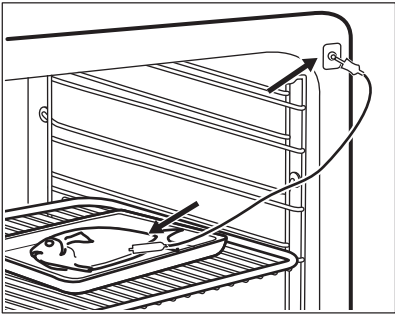
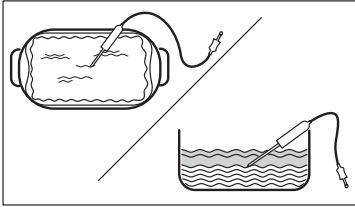
ANVÄNDNING AV TILLBEHÖR



Steg 2	Ställ in en tillagningsfunktion och, vid behov, ugnstemperatur.
Steg 3	Sätt in: Matlagningstermometer.
Kött, fågel och fisk	Gryta
Sätt in spetsen på Matlagningstermometer i mitten av köttet eller fisken eller i den tjockaste delen. Se till att minst 3/4 av Matlagningstermometer är inuti det du tillagar.	Sätt in spetsen på Matlagningstermometer exakt i mitten av grytan. Matlagningstermometer ska sitta stabilt på samma ställe under tillagningen. Använd en fast ingrediens för det. Använd kanten på den ugnsfasta formen som stöd för silikonhandtaget. Matlagningstermometer. Spetsen på Matlagningstermometer får inte vidröra den ugnsfasta formens botten.
	
Steg 4	Kontakt Matlagningstermometer i uttaget framtill i ugnen. På displayen visas aktuell temperatur för: Matlagningstermometer.
Steg 5	 - tryck för att ställa in tillagningstemperaturen.
Steg 6	<ul style="list-style-type: none"> • • • - tryck för att ställa in önskat alternativ: • Ljudalarm – en ljudsignal avges när maten når den inställda temperaturen. • Ljudalarm och avsluta matlagning – en ljudsignal avges och ugnen stängs av när maten når den inställda temperaturen.
Steg 7	Välj funktion och tryck upprepade gånger på: OK för att komma till huvudskärmen.
Steg 8	Tryck på: START . En ljudsignal avges när maten når den inställda temperaturen. Du kan välja att stoppa eller fortsätta tillagningen för maten ska bli tillräckligt tillagad.

Steg 9	<p>Dra ut Matlagningstermometer kontakt ur uttaget och ta ut maten ur ugnen.</p> <div style="border: 1px solid black; padding: 5px;">  <p>VARNING! Det finns risk för brännskador när Matlagningstermometer blir varm. Var försiktig när du drar ut den från kontakten och från maten.</p> </div>
---------------	-----------------------------------------------------------------------------------------------------------------------------------------------------------------------------------------------------------------------------------------------------------------------------------------------------------------------------------------------------------------------------------------------

9. TILLVALSFUNKTIONER



9.1 Så här sparar du: Favoriter

Du kan spara dina favoritinställningar, som tillagningsfunktion, tillagningstid, temperatur eller rengöringsfunktion. Du kan spara 3 favoritinställningar.

Steg 1	Slå på ugnen.
Steg 2	Välj önskad inställning.
Steg 3	Tryck på:  . Välj: Favoriter.
Steg 4	Välj: Spara aktuell inställning.
Steg 5	Tryck på + för att lägga till inställningen till listan av: Favoriter. Tryck på OK.
<p> – tryck för att återställa inställningen.</p> <p> – tryck för att avbryta inställningen.</p>	

9.2 Funktionslås



Funktionen förhindrar att tillagningsfunktionen ändras oavsiktligt.

Steg 1	Slå på ugnen.
Steg 2	Ställ in en tillagningsfunktion.
Steg 3	  – tryck samtidigt för att slå på funktionen.
Upprepa steg 3 för att stänga av funktionen.	

9.3 Automatisk avstängning

Av säkerhetsskäl stängs ugnen av efter en tid om en uppvärmningsfunktion är aktiv och inga inställningar ändras.

RÅD OCH TIPS

 (°C)	 (tim)
30 - 115	12.5
120 - 195	8.5
200 - 245	5.5
250 - maximalt	3

Automatisk avstängning fungerar inte med funktionerna: Belysning, Matlagningstermometer, Sluttid, Långsam tillagning.

9.4 Kylfläkt

När ugnen är på, slås fläkten på automatiskt för att hålla ugnens ytor svala. Om du stänger av ugnen fortsätter fläkten att gå tills ugnen svalnat.





10. RÅD OCH TIPS





10.1 Tillagningsrekommendationer

<p>Temperatur och tillagningstid i tabellerna är endast riktvärden. Hur de ska väljas beror på recept och ingrediensernas kvalitet och mängd.</p> <p>Ugnen kan baka eller steka annorlunda än din gamla ugn. Tabellerna nedan visar rekommenderade inställningar för temperatur, tillagningstid och hyllposition för specifika typer av mat.</p> <p>Om du inte kan hitta inställningarna för ett visst recept kanske du kan använda inställningarna för ett liknande recept.</p> <p>För mer matlagningssrekommendationer, se matlagningstabeller på vår hemsida. Du hittar matlagningstips genom att kontrollera PNC-numret på märkskylten på främre ramen i ugnsutrymmet.</p>

10.2 Bakning med fukt





För bästa resultat ska du följa förslagen som listas i tabellen nedan.

		 (°C)		 (min.)
Vetebullar, 16 st	långpanna eller djup form	180	2	25 - 35
Rulltårta	långpanna eller djup form	180	2	15 - 25

		 (°C)		 (min.)
Hel fisk, 0,2 kg	långpanna eller djup form	180	3	15 - 25
Småkakor, 16 st	långpanna eller djup form	180	2	20 - 30
Macaroons, 24 st	långpanna eller djup form	160	2	25 - 35
Muffins, 12 st	långpanna eller djup form	180	2	20 - 30
Matpaj, 20 st	långpanna eller djup form	180	2	20 - 30
Mördegsbakor, 20 st	långpanna eller djup form	140	2	15 - 25
Tarteletter, 8 st	långpanna eller djup form	180	2	15 - 25

10.3 Bakning med fukt - rekommenderade tillbehör

Använd mörka och icke reflekterande burkar och formar. De absorberar värme bättre än ljusa färger och reflektiva formar.

			
Pizzaform	Ugnsform	Portionsform	Tårtbottenform
Mörk, icke reflekterande 28 cm diameter	Mörk, icke reflekterande 26 cm diameter	Keramik 8 cm diameter, 5 cm hög	Mörk, icke reflekterande 28 cm diameter





10.4 Tillagningstabeller för testinstitut

Information för testinstitut





Tester enligt: EN 60350, IEC 60350.

RÅD OCH TIPS





Bakning på en nivå – bakning i formar

		 °C	 min	
Sockerkaka utan fett	Varmluft	160	45 - 60	2
Sockerkaka utan fett	Över-/undervärme	160	45 - 60	2
Äppelpaj, 2 st 20 cm formar	Varmluft	160	55 - 65	2
Äppelpaj, 2 st 20 cm formar	Över-/undervärme	180	55 - 65	1
Mördegskakor	Varmluft	140	25 - 35	2
Mördegskakor	Över-/undervärme	140	25 - 35	2





Bakning på en nivå – kex
Använd den tredje hyllpositionen.

		 °C	 min
Småkakor, 20 st/plåt, förvärm den tomma ugnen	Varmluft	150	20 - 30
Småkakor, 20 st/plåt, förvärm den tomma ugnen	Över-/undervärme	170	20 - 30

Bakning på flera nivåer – kex

		 °C	 min	
Mördegskakor	Varmluft	140	25 - 45	2 / 4
Småkakor, 20 st/plåt, förvärm den tomma ugnen	Varmluft	150	25 - 35	1 / 4
Sockerkaka utan fett	Varmluft	160	45 - 55	2 / 4





SKÖTSEL OCH RENGÖRING

		 °C	 min	
Äppelpaj, 1 burk per galler (Ø 20 cm)	Varmluft	160	55 - 65	2 / 4

Grill

Förvärm den tomma ugnen i 5 minuter.

Grillning med maximal temperaturinställning.

		 min	
Rostat bröd	Grill	1 - 2	5
Nötstek, vänd efter halva tiden	Grill	24 - 30	4



11. SKÖTSEL OCH RENGÖRING



WARNING!

Se Säkerhetsavsnitten.

11.1 Rengöring

 Rengöringsmedel	Rengör ugnens framsida med en mikrofiberduk med varmt vatten och ett mildt rengöringsmedel.
	Använd en rengöringslösning för att rengöra metalldelar.
	Rengör fläckar med ett mildt diskmedel.
 För användning varje dag	Rengör ugnsutrymmet efter varje användningstillfälle. Fettansamling eller andra matrester kan leda till brand.
	Låt inte maten stå i ugnen längre än 20 minuter. Torka ugnsutrymmet med enbart en mikrofiberduk efter varje användning.

SKÖTSEL OCH RENGÖRING

 Tillbehör	Rengör alla tillbehör efter varje användningstillfälle och låt dem torka. Använd enbart en mikrofiberduk med varmt vatten och ett mildt rengöringsmedel. Diska inte tillbehören i diskmaskin.
	Använd inte rengöringsmedel med slipeffekt eller vassa föremål när du rengör SuperClean-tillbehören.

11.2 Hur man tar bort: Ugnsstegar

Ta bort ugnsstegarna vid rengöring av ugnen.

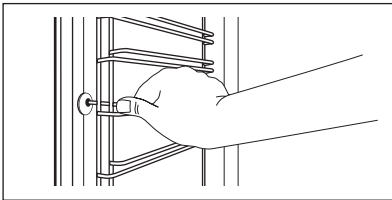
Steg 1	Stäng av ugnen och vänta tills den har svalnat.	
Steg 2	Dra försiktigt ugnsstegen uppåt och ut ur den främre upphängningen.	
Steg 3	Dra först ut stegarnas främre del från sidoväggen.	
Steg 4	Dra ur stöden från de bakre karnarna.	
Sätt tillbaka ugnsstegar i omvänd ordning.		

11.3 Så här använder du: Pyrolytisk rengöring

Rengör ugnen med Pyrolytisk rengöring.

**WARNING!**

Det finns risk för brännskador.

**FÖRSIKTIGHET!**

Om andra produkter är monterade i samma skåp får de inte användas samtidigt som den här funktionen. Det kan skada ugnen.

Före Pyrolytisk rengöring:

Stäng av ugnen och vänta tills den har svalnat.	Ta bort alla tillbehör.	Rengör ugnsbotten och innerglaset på luckan med varmt vatten, mjuk trasa och mildt rengöringsmedel.
-------------------------------------------------	-------------------------	-----------------------------------------------------------------------------------------------------

Fyll inte på vattenbehållaren under rengöringen. Det gör att rengöringscykeln startar om.

Steg 1	Slå på ugnen.
---------------	---------------

Steg 2	Tryck på:  /Rengöring.	
Steg 3	Sätt plåten på den första hyllpositionen för att samla upp vatten från vattenbehållaren. OK – tryck för att vattenbehållaren ska börja tömmas.	
Steg 4	Ta bort bakplåten och de flyttbara ugnsstegarna när tömningen av tanken är klar. Torka ur ugnen och innerglaset med en mjuk trasa. Tryck på: OK .	
Steg 5	Välj rengöringsläge.	
Funktion	Rengöringsläge	Koktid
Pyrolytisk rengöring, snabb	Lätt rengöring	1 h
Pyrolytisk rengöring, normal	Normal rengöring	1 h 30 min
Pyrolytisk rengöring, intensiv	Grundlig rengöring	3 h
<p>i När rengöringen startar är lampan släckt och kylfläkten går på en högre hastighet. STOP – tryck för att avsluta rengöringen innan den är klar. Använd inte ugnen förrän luckans låssymbol försvinner från displayen.</p>		

När rengöringen är klar:

Stäng av ugnen och vänta tills den har svalnat.	Torka ur ugnen invändigt med en mjuk trasa.	Ta bort rester från ugnens botten.
-------------------------------------------------	---------------------------------------------	------------------------------------

11.4 Påminnelse om rengöring

När påminnelsen visas bör ugnen rengöras.
Använd funktionen: Pyrolytisk rengöring.

11.5 Så här använder du: Avkalkning

Innan du startar:		
Stäng av ugnen och vänta tills den har svalnat.	Ta bort alla tillbehör.	Kontrollera att vattenlådan är tom.

SKÖTSEL OCH RENGÖRING

Varaktighet för första delen: ca 100 min	
Steg 1	Sätt långpannan på den nedersta ugnsnivån.
Steg 2	Häll 250 ml avkalkningsmedel i vattenlådan.
Steg 3	Fyll återstående delen av vattenlådan med vatten till maxnivån tills ljudsignalen hörs eller meddelandet visas på displayen.
Steg 4	Välj: Meny / Rengöring.
Steg 5	Slå på funktionen och följ instruktionerna på skärmen. Första delen av avkalkningen startar.
Steg 6	I slutet av den första delen ska långpannan tömmas och placeras på den första ugnsnivån igen.
Varaktighet för den andra delen: cirka 35 minuter	
Steg 7	Fyll återstående delen av vattenlådan med vatten till maxnivån tills ljudsignalen hörs eller meddelandet visas på displayen.
Steg 8	Ta bort långpannan när funktionen har avslutats.
 Lampan är släckt medan funktionen pågår.	

När avkalkningen är klar:		
Stäng av ugnen.	När ugnen har svalnat kan den rengöras med en mjuk trasa.	Låt luckan stå öppen och vänta tills ugnsutrymmet är torrt.
 Om några kalkavlagringar blir kvar i ugnen efter avkalkning, kommer displayen att uppmana dig att upprepa proceduren.		

11.6 Avkalkningspåminnelse

Det finns två påminnelser som uppmanar dig att avkalka ugnen. Du kan inte avaktivera avkalkningspåminnelsen.

Typ	Beskrivning
Svag påminnelse	Rekommenderar att du ska avkalka ugnen.

Typ	Beskrivning
Hård påminnelse	Säger att du måste avkalka ugnen. Du kan inte använda ugnen om du inte avkalkar den när den hårda påminnelsen är på.

11.7 Så här använder du: Sköljning

Innan du startar:	
Stäng av ugnen och vänta tills den har svalnat.	Ta bort alla tillbehör.

Steg 1	Sätt långpannan på den nedersta ugnsnivån.
Steg 2	Fyll vattenlådan med vatten till maxnivån tills ljudsignalen hörs eller meddelandet visas på displayen.
Steg 3	Välj: Meny / Rengöring / Sköljning. Varaktighet: cirka 30 min
Steg 4	Slå på funktionen och följ instruktionerna på skärmen.
Steg 5	Ta bort långpannan när funktionen har avslutats.
 Lampan är släckt medan funktionen pågår.	

11.8 Användning: Tömning av tanken

Använd den efter tillagning med ångtillagningsfunktion för att ta bort det återstående vattnet från vattenlådan.

Innan du startar:	
Stäng av ugnen och vänta tills den har svalnat.	Ta bort alla tillbehör.

Steg 1	Sätt långpannan på den nedersta ugnsnivån.
Steg 2	Välj: Meny / Rengöring / Tömning av tanken. Varaktighet: 6 min.
Steg 3	Slå på funktionen och följ instruktionerna på skärmen.
Steg 4	Ta bort långpannan när funktionen har avslutats.

ⓘ Lampan är släckt medan funktionen pågår.

11.9 Hur man tar bort och installerar: Luckan

Man kan ta loss och rengöra luckan och de inre glasrutorna. Antalet glaspaneler skiljer sig åt för olika modeller.



VARNING!
Luckan är tung.



FÖRSIKTIGHET!
Hantera glaset varsamt, särskilt runt den främre panelens kanter. Glaset kan gå sönder.

Steg 1	Öppna luckan helt.	
Steg 2	Lyft och tryck in klämspärarna (A) på de två gångjärnen till luckan.	
Steg 3	Stäng ugnsluckan till den första öppna positionen (ungefär 70° vinkel). Håll i luckan på båda sidorna och dra den ut från ugnen i en uppåtgående vinkel. Lägg ner luckan med utsidan neråt på en mjuk handduk på ett stabilt underlag.	
Steg 4	Ta tag i lucklisten (B) på båda sidorna av luckans övre kant och tryck inåt för att frigöra klämlåset.	
Steg 5	Dra lucklisten framåt för att ta bort den.	
Steg 6	Håll glaset i överkanten ett i taget och dra dem uppåt och ut ur skenan.	

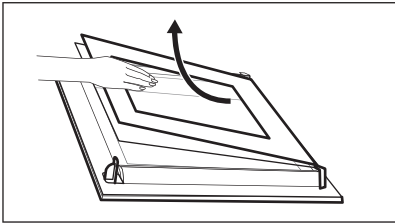
Steg 7	Rengör glaset med vatten och tvål. Torka luckglaset nogga. Diska inte glasskivorna i diskmaskin.	
Steg 8	Efter rengöring, utför stegen ovan i omvänd ordning.	
Steg 9	Sätt i det mindre ugnsglaset först, därefter det större och sist luckan.	

11.10 Byte av: Lampa



WARNING!

Risk för elektrisk stöt!
Lampan kan vara het.

Innan du byter lampan:

Steg 1	Steg 2	Steg 3
Stäng av ugnen. Vänta tills ugnen är kall.	Koppla bort ugnen från eluttaget.	Lägg en trasa i botten av ugnsutrymmet.

Övre lampa

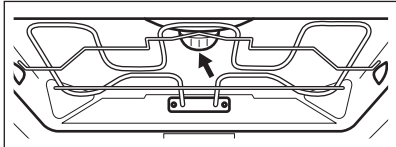
Steg 1	Ta bort glasskyddet genom att vrida på det.	
Steg 2	Avlägsna metallringen och rengör glaskåpan.	
Steg 3	Byt ut lampan mot en passande som tål upp till 300 °C. °C	
Steg 4	Sätt dit metallringen på skyddsglasets och installera det.	

Sidolampa

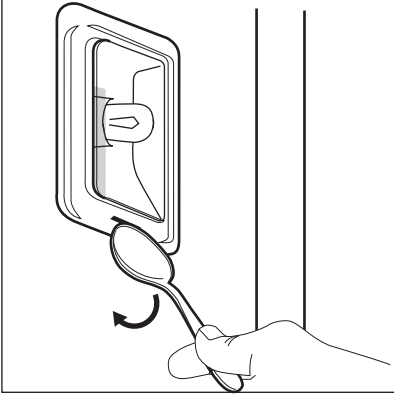
Steg 1	Avlägsna det vänstra hyllstödet för att komma åt lampan.	
Steg 2	Använd ett smalt, trubbigt föremål (t.ex. en tesked) för att ta bort glasskyddet.	
Steg 3	Rengör glasskyddet.	
Steg 4	Byt ut lampan mot en passande som är värmetålig upp till 300 °C.	
Steg 5	Sätt tillbaka glasskyddet.	
Steg 6	Montera det vänstra hyllstödet.	



12. FELSÖKNING









VARNING!

Se Säkerhetsavsnitten.

12.1 Vad gör jag om ...

 Ugnen inte startar eller inte värms upp	
 Möjlig orsak	 Åtgärd
Ugnen är inte ansluten till strömförsörjningen eller den är ansluten på fel sätt.	Kontrollera att ugnen är korrekt ansluten till strömförsörjningen.
Klockan är inte inställd.	Ställ in klockan. Mer information finns i Klockfunktioner kapitlet, Så här ställer du in: Klockfunktioner.
Luckan är inte ordentligt stängd.	Stäng luckan helt.
Säkringen har gått.	Kontrollera om säkringen är orsaken till felet. Om problemet återkommer ska du kontakta en kvalificerad elektriker.



 Ugnen inte startar eller inte värms upp	
 Möjlig orsak	 Åtgärd
apparaten Barnlås är på.	Se kapitlet "Meny", undermeny för: Tillval.

 Komponenter	
 Beskrivning	 Åtgärd
Glödlampen är trasig.	Byt lampa, för mer information se kapitlet "Underhåll och rengöring", Hur man byter: Lampa.

Strömavbrott stänger alltid av rengöringen. Upprepa rengöringen om det blir ett strömavbrott.

12.2 Hur man hanterar: Felkoder

När mjukvarufel uppstår visar displayen ett felmeddelande. I det här avsnittet får du en lista över problem du kan hantera själv.

 Kod och beskrivning	 Åtgärd
C2 – Matlagningstermometer är i ugnsutrymmet under Pyrolytisk rengöring.	Ta ut Matlagningstermometer.
C3 – luckan är inte helt stängd under Pyrolytisk rengöring.	Stäng dörren.
F111 – Matlagningstermometer är inte korrekt insatt i uttaget.	Sätt i Matlagningstermometer i uttaget.
F240, F439 – touchområdet på displayen fungerar inte som de ska.	Rengör ytan på displayen. Se till att det inte är någon smuts på touchområdet.
F908 – ugnssystemet kan inte ansluta till kontrollpanelen.	Slå på och stänga av ugnen.

12.3 Servicedata

Kontakta din återförsäljare eller en auktoriserad serviceverkstad om du inte kan avhjälpa felet.

ENERGIEFFEKTIVITET

Nödvändig information som servicecentret behöver finns på graderingsskylten. Typskylten sitter på ugnsutrymmets främre ram. Avlägsna inte typskylten från ugnsutrymmet.

Vi rekommenderar att du antecknar uppgifterna här:	
Modell (MOD.)
Produktnummer (PNC)
Serienummer (S.N.)

13. ENERGIEFFEKTIVITET

13.1 Produktinformation och produktinformationsblad

Leverantörens namn	AEG	
Modellidentifiering	BSE77280M 944188685 BSE77228BM 944188655 BSK772280M 944188643 BSS772280B 944188644	
Energieffektivitetsindex	61.2	
Energieffektivitetsklass	A++	
Energiförbrukning med standardbelastning, konventionellt läge	1.09 kWh/cykel	
Energiförbrukning med standardbelastning, varmluftsläge	0.52 kWh/cykel	
Antal kaviteter	1	
Värmekälla	Elektricitet	
Volym	71 l	
Typ av ugn	Inbyggd ugn	
Massa	BSE772280M	36.0 kg
	BSE77228BM	36.0 kg
	BSK772280M	36.0 kg
	BSS772280B	36.0 kg

IEC/EN 60350-1 - Elektriska hushållsapparater för matlagning - Del 1: Sortiment, ugnar, ångugnar och grillar - metoder för att mäta prestanda.

13.2 Energibesparing



Denna produkt har funktioner som låter dig spara energi under vanlig matlagning.

Kontrollera att ugnsluckan är ordentligt stängd när ugnen är påslagen. Öppna inte ugnsluckan för ofta under tillagningen. Håll luckans tätningsslist är ren och kontrollera att den sitter rätt och ordentligt fast.

Använd kokkärl i metall för högre energieffektivitet.

Om möjligt, undvik att förvärma ugnen före tillagning.

Gör så korta uppehåll som möjligt vid tillagning av flera rätter för samma tillfälle.

Tillagning med varmluft

Om möjligt, använd varmluftsfunktionen för att spara energi.

Restvärme

Om ett program med Kottid aktiveras och tillagningstiden är längre än 30 minuter, stängs värmeelementen automatiskt av tidigare i vissa produktfunktioner.

Fläkten och belysningen fortsätter att vara påslagna. När du stänger av ugnen visas restvärme på displayen. Du kan använda den värmen för varmhållning.

Om tillagningen tar längre tid än 30 minuter, sänk ugnstemperaturen med minst 3–10 minuter innan tillagningen avslutas. Tillagningen fortsätter med ugnens restvärme.

Använd restvärmen för att värma annan mat.

Varmhållning

Välj lägsta möjliga temperaturinställning för att använda restvärme och hålla maten varm.

Restvärmeindikatorn eller temperaturen visas på displayen.

Laga mat med släckt belysning

Släck belysningen under tillagning. Tänd den endast när du behöver den.

Bakning med fukt

Denna funktion används för att spara energi under tillagningen.

Med denna funktion släcks belysningen automatiskt efter 30 sekunder. Du kan tända belysningen igen, men det innebär att förväntad energibesparing minskar.

14. MENYSTRUKTUR

14.1 Meny

Menyalternativ	Program
Assisterad matlagning	Förteckning av automatiska program.
Rengöring	Förteckning av rengöringsprogram.
Favoriter	Förteckning av favoritinställningar.
Tillval	Används för att ställa in ugnskonfigurationen.

Menyalternativ		Program
Inställningar	Inställningar	Används för att ställa in ugnskonfigurationen.
	Service	Visar programvarans version och konfiguration.

14.2 Undermeny för: Rengöring

Undermeny	Användning
Tömning av tanken	Procedur för att avlägsna restvatten från vattenlådan efter användning av ångfunktionen.
Pyrolytisk rengöring, snabb	Tillagningstid: 1 h.
Pyrolytisk rengöring, normal	Tillagningstid: 1 h 30 min.
Pyrolytisk rengöring, intensiv	Tillagningstid: 3 h.
Avkalkning	Metod för att rengöra ångkretsen på kalkavlagringar.
Sköljning	Metod för att skölja och rengöra ångkretsen när ångfunktionerna använts ofta.

14.3 Undermeny för: Tillval

Undermeny	Användning
Belysning	Tänder och släcker lampan.
Barnlås	Förhindrar oavsiktlig påslagning av ugnen. När valet är aktiverat visas texten Barnlås på displayen när du sätter på produkten. Aktivera ugnen genom att sätta kodbokstäverna i alfabetisk ordning. När valet är aktiverat och produkten är avstängd är produktens lucka låst. Åtkomsten till timern, fjärrstyrningen och belysningen är tillgänglig när valet är aktiverat.
Snabbuppvärmning	Förkortar uppvärmningstiden. Det är endast tillgängligt för vissa ugnsfunktioner.
Visa klocka i standby	Slår på och stänger av tiden.

Undermeny	Användning
Klocka i digital stil	Ändrar formatet för tidsvisning.

14.4 Undermeny för: Inställningar



Undermeny	Beskrivning. Används för att:
Språk	Ställer in ugnens språk.
Ljusstyrka i display	Ställer in ljusstyrkan på displayen.
Knappljud	Slår på och stänger av ljudsignal för pekkontrollerna. Det går inte att stänga av ljudsignalen för: ①.
Ljudvolym knappar	Ställer in volymen på knappljud och signaler.
Vattenhårdhet	Ställer in vattnets hårdhetsgrad.
Klockslag	Ställer in aktuell tid och datum.



14.5 Undermeny för: Service



Undermeny	Beskrivning. Används för att:
Demoläge	Aktiverings-/avaktiveringskod: 2468
Programversion	Information om programversion.
Återställ alla inställningar	Återställer till fabriksinställningar.

15. ENKELT!

Före första användningen måste du ställa in:					
Språk	Ljusstyrka i display	Knappljud	Ljudvolym knappar	Vattenhårdhet	Klockslag



Börja använda ugnen				
Snabbstart	Sätt på ugnen och starta matlagningen med standardtemperaturen och tiden för funktionen.	Steg 1	Steg 2	Steg 3
		Tryck och håll in: 	 ... - Välj önskad funktion.	Tryck på: START .
Snabb avstängning	Stäng av ugnen, displayen och meddelandet när som helst.	 – tryck och håll in tills ugnen stängs av.		

Börja tillagningen				
Steg 1	Steg 2	Steg 3	Steg 4	Steg 5
 – tryck för att slå på ugnen.	 ... - Välj tillagningsfunktion.	°C – ställ in temperaturen.	OK – tryck för att bekräfta.	START – tryck för att starta tillagningen.

Lär dig att laga mat snabbt				
Använd de automatiska programmen för att tillaga en rätt snabbt med standardinställningarna:				
Assisterad matlagning	Steg 1	Steg 2	Steg 3	Steg 4
	Tryck på: 	Tryck på: 	Tryck på:  Assisterad matlagning.	Välj maträtt.

Välj tillagningstid med snabbfunktionerna	
10 % Finish assist Använd 10 % Finish assist för att lägga till extra tid när 10 % av tillagningstiden återstår.	Tryck på +1min för att förlänga tillagningstiden.

16. MILJÖSKYDD

Återvinn material med symbolen . Återvinn förpackningen genom att placera den i lämpligt kärl. Bidra till att skydda vår miljö och vår hälsa genom att återvinna avfall från elektriska och elektroniska produkter. Släng inte produkter märkta med symbolen  med hushållsavfallet. Lämna in produkten på närmaste återvinningsstation eller kontakta kommunkontoret.

www.aeg.com/shop



867371102-C-032023



AEG