

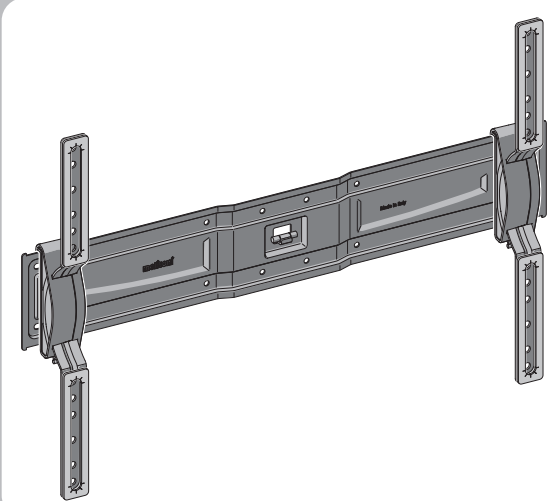

Ghost Slim PLUS T600



IT ISTRUZIONI DI MONTAGGIO
 FR INSTRUCTIONS DE MONTAGE
 EN MOUNTING INSTRUCTIONS
 DE MONTAGEANLEITUNG
 NL MONTAGEVOORSCHRIFT
 ES GUÍA DE MONTAJE
 PT INSTRUÇÕES DE MONTAGEM
 PL INSTRUKCJA MONTAŻU
 CZ NÁVOD K MONTÁŽI
 RO INSTRUCȚIUNI DE MONTARE
 HU SZERELÉSI ÚTMUTATÓ
 FI ASENNUSOHJEET
 SK NÁVOD NA MONTÁŽ
 SL NAVODILA ZA MONTAŽO
 MK ИНСТРУКЦИИ ЗА МОНТАЖА
 SQ UDHËZIME PËR MONTIMIN

IT Attrezzatura per montaggio FR Outils d'assemblage ES Herramientas de montaje

Assembley equipment

IT Dati tecnici FR Caractéristiques techniques EN Technical data ES Datos técnicos

50" - 85" MAX
127 - 214 cm

65 kg MAX
143 lbs

T600
2.1 kg
4.62 lbs

VESA
Max 600 mm
X
Max 400 mm

TV (x4) Ø6 Ø8

TV (x4) Ø6 Ø8

1:1

5 (x6) Ø5 x 50 L4468139 Ø8

TV (x4) Ø8 x 30 L7950203

TV (x4) Ø8 x 20 L7950137

TV (x4) Ø8 x 15 L4459513

TV (x4) Ø6 x 30 L7950139

TV (x4) Ø6 x 15 L4459513

TV (x4) Ø6 x 16 L7950244

1

(x4)

TV (x4) Ø6 Ø8

TV (x4) Ø6 Ø8 OPTIONAL

2a

2b

TV TV TV TV TV TV TV TV CURVED TV

3

a

b

c

X = cm + Y = cm = X+Ycm = cm **

4

UP meliconi

(x6)

X+Y **

5

60 mm (2.4")

max 12 mm (0.5")

Ø 8 mm

(x6)

6

(x6)

4

UP meliconi

(x6)

X+Y **

5

Ø 2,5 mm

60 mm (2.4")

max 12 mm (0.5")

(x6)

6

(x6)

7

OK!

OK!

OK!

(x6)

Meliconi S.p.A. - V. Minghetti, 10
 40057 Cadriano di Granarolo E. (BO) Italy
 www.meliconi.com e-mail: info@meliconi.com



