

CARATTERISTICHE TECNICHE | DATA SHEET DONNÉES TECHNIQUES | TECHNISCHE DATEN

HOME LINE 200-250

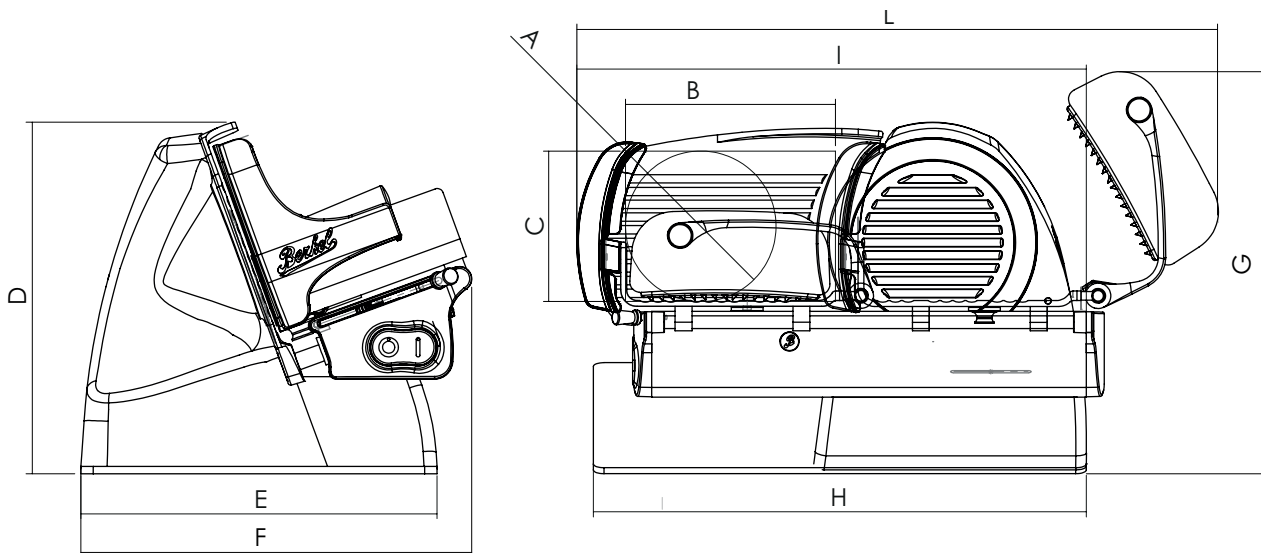

	SPECIFICHE SPECIFICATIONS SPÉCIFICATIONS TECHNISCHE MERKMALE		DIMENSIONI DIMENSIONS MASSE	
	HL200	HL250	HL200	HL250
∅ Lama ∅ Blade ∅ Lame ∅ Messer	195 mm	250 mm	A 140 mm	A 183 mm
Spessore taglio Cut thickness Epaisseur de coupe Schnittbreite	0 - 20 mm	0 - 20 mm	B 200 mm	B 200 mm
Capacità di taglio circolare Capacity (circle) Capacité (cercle) Leistung (Kreis)	140 mm	183 mm	C 140 mm	C 183 mm
Capacità di taglio rettangolare Capacity (rectangle) Capacité (rectangle) Leistung (Rechteck)	200x140 mm	200x183 mm	D 284 mm	D 315 mm
Peso netto Net weight Poids net Nettogewicht	12,5 kg	14,5 kg	E 290 mm	E 290 mm
Potenza motore Motor rating Puissance moteur Motorleistung	0,19 kW	0,19 kW	F 318 mm	F 340 mm
Specifiche elettriche Electrical specifications Caractéristiques électriques Elektrische Eigenschaften	230 V 50 Hz	230 V 50 Hz	G 325 mm	G 353 mm
			H 450 mm	H 450 mm
			I 470 mm	I 552 mm
			L 640 mm	L 660 mm

Nota: A seguito della continua ricerca per migliorare sempre i nostri prodotti, le specifiche tecniche sono soggette a possibili variazioni
 Note: As we actually strive to improve our products, specifications are necessarily subject to change without notice
 Remarque: En raison de la recherche continue pour améliorer nos produits, les spécifications techniques sont sujettes à des possibles variations
 Anmerkung: Aufgrund der ständigen Forschung für die Verbesserung unserer Produkte, die Produktionsvorgabe können Änderungen zeigen